

NUMBER OF PARCELS: 7  
NUMBER OF LETTERED PARCELS: 4  
ACREAGE IN PARCELS: 297.89  
ACREAGE IN LETTERED PARCEL: 33.35  
TOTAL ACREAGE: 331.24

IN THE CITY OF BEAUMONT, COUNTY OF RIVERSIDE, STATE OF CALIFORNIA  
**PARCEL MAP NO. 31368**  
BEING A SUBDIVISION OF A PORTION OF SECTION 5, TOWNSHIP 3 SOUTH, RANGE 1 WEST, SAN BERNARDINO BASE AND MERIDIAN, AS SHOWN BY UNITED STATES GOVERNMENT SURVEY.

City 229  
46  
SHEET 1 OF 8 SHEETS

NOTE:  
THIS MAP HAS BEEN RECORDED FOR FINANCING AND CONVEYANCE PURPOSES ONLY. NO USE IS PERMITTED WITHOUT ADDITIONAL CITY APPROVALS.

**OWNER'S STATEMENT**

WE HEREBY STATE THAT WE ARE THE OWNERS OF THE LAND INCLUDED WITHIN THE SUBDIVISION SHOWN HEREON; THAT WE ARE THE ONLY PERSONS WHOSE CONSENT IS NECESSARY TO PASS A CLEAR TITLE TO SAID LAND; THAT WE CONSENT TO THE MAKING AND RECORDING OF THIS SUBDIVISION MAP AS SHOWN WITHIN THE DISTINCTIVE BORDER LINE.

WE HEREBY DEDICATE TO THE PUBLIC USE FOR STREET AND PUBLIC UTILITY PURPOSES PARCEL "A" - POTRERO BOULEVARD, PARCEL "C" - GEORGE LANE AND PARCEL "D" - GERALD WAY.

WE ALSO HEREBY DEDICATE PARCEL "B" TO THE CITY OF BEAUMONT FOR SEWER LIFT STATION AND INCIDENTAL PURPOSES.

CATHAY BANK, A CALIFORNIA BANKING CORPORATION

BY: [Signature]  
GARY A. COOK  
SENIOR VICE PRESIDENT, REAL ESTATE

BY: [Signature]  
DONNA LEW  
VICE PRESIDENT

**NOTARY ACKNOWLEDGEMENT**

STATE OF CALIFORNIA }  
COUNTY OF LOS ANGELES }

ON 7-13-09 BEFORE ME, Suet Shan Sun, A NOTARY PUBLIC,  
(INSERT NAME AND TITLE OF OFFICER)  
PERSONALLY APPEARED Gary A. Cook and Donna Lew

WHO PROVED TO ME ON THE BASIS OF SATISFACTORY EVIDENCE TO BE THE PERSON(S) WHOSE NAME(S) IS/ARE SUBSCRIBED TO THE WITHIN INSTRUMENT AND ACKNOWLEDGED TO ME THAT HE/SHE/THEY EXECUTED THE SAME IN HIS/HER/THEIR AUTHORIZED CAPACITY(IES), AND THAT BY HIS/HER/THEIR SIGNATURE(S) ON THE INSTRUMENT THE PERSON(S), OR THE ENTITY UPON BEHALF OF WHICH THE PERSON(S) ACTED, EXECUTED THE INSTRUMENT.

I CERTIFY UNDER PENALTY OF PERJURY UNDER THE LAWS OF THE STATE OF CALIFORNIA THAT THE FOREGOING PARAGRAPH IS TRUE AND CORRECT.

WITNESS MY HAND

[Signature]  
SIGNATURE  
Suet Shan Sun  
PRINT NAME

MY COMMISSION EXPIRES March 8, 2013

MY PRINCIPAL PLACE OF BUSINESS IS IN Los Angeles COUNTY.

**TAX BOND CERTIFICATE**

I HEREBY CERTIFY THAT A BOND IN THE SUM OF \$ 294,200.00 HAS BEEN EXECUTED AND FILED WITH THE BOARD OF SUPERVISORS OF THE COUNTY OF RIVERSIDE, CALIFORNIA, CONDITIONED UPON THE PAYMENT OF ALL TAXES, STATE, COUNTY, MUNICIPAL, OR LOCAL AND ALL SPECIAL ASSESSMENTS COLLECTED AS TAXES, WHICH AT THE TIME OF FILING OF THIS MAP WITH THE COUNTY RECORDER ARE A LIEN AGAINST SAID PROPERTY BUT NOT YET PAYABLE AND SAID BOND HAS BEEN DULY APPROVED BY SAID BOARD OF SUPERVISORS.

DATED 8/20/09  
CASH TAX BOND  
DON KENT, COUNTY TAX COLLECTOR  
BY: [Signature] DEPUTY

KECIA HARPER-IHEM  
CLERK OF THE BOARD OF SUPERVISORS  
BY: \_\_\_\_\_ DEPUTY

**TAX COLLECTOR'S CERTIFICATE**

I HEREBY CERTIFY THAT ACCORDING TO THE RECORDS OF THIS OFFICE, AS OF THIS DATE, THERE ARE NO LIENS AGAINST THE PROPERTY SHOWN ON THE WITHIN MAP FOR UNPAID STATE, COUNTY, MUNICIPAL, OR LOCAL TAXES OR SPECIAL ASSESSMENTS COLLECTED AS TAXES EXCEPT TAXES OR SPECIAL ASSESSMENTS COLLECTED AS TAXES NOW A LIEN BUT NOT YET PAYABLE WHICH ARE ESTIMATED TO BE \$ 294,200.00

DATED 8/20/09

PAUL McDONNELL, COUNTY TAX COLLECTOR  
DON KENT  
BY: [Signature] DEPUTY

**SOILS REPORT:**

A PRELIMINARY GEOTECHNICAL INVESTIGATION AND RCIP FAULT HAZARD ZONE INVESTIGATION WAS PREPARED ON THE 16TH DAY OF OCTOBER, 2008, AS A REQUIRED BY SECTION 17953 OF THE HEALTH AND SAFETY CODE OF CALIFORNIA, BY PACIFIC SOILS ENGINEERING, INC., A COPY OF SAID REPORT IS ON FILE FOR PUBLIC INSPECTION IN THE CITY ENGINEER'S OFFICE.

**RECORDER'S STATEMENT:**

FILED THIS 25<sup>th</sup> DAY OF August, 2009  
AT 8 A.M. IN BOOK 221 OF PARCEL MAPS,  
AT PAGES 46-53, AT THE REQUEST OF  
THE CLERK OF THE BOARD.

NO: 2009-0442874  
FEE: \$ 24.00  
LARRY W. WARD, ASSESSOR-COUNTY CLERK-RECORDER  
BY: [Signature], DEPUTY  
SUBDIVISION GUARANTEE: FIRST AMERICAN  
TITLE COMPANY

**ENGINEER'S STATEMENT**

THIS MAP WAS PREPARED BY ME OR UNDER MY DIRECTION AND IS BASED UPON A FIELD SURVEY IN CONFORMANCE WITH THE REQUIREMENTS OF THE SUBDIVISION MAP ACT AND LOCAL ORDINANCE AT THE REQUEST OF STEVE KING ON JANUARY 7, 2008. I HEREBY STATE THAT ALL MONUMENTS ARE OF THE CHARACTER AND OCCUPY THE POSITIONS INDICATED, OR WILL BE IN ACCORDANCE WITH THE TERMS OF THE MONUMENT AGREEMENT FOR THE MAP, AND THAT SAID MONUMENTS WILL BE SUFFICIENT TO ENABLE THE SURVEY TO BE RETRACED. I HEREBY STATE THAT THIS PARCEL MAP SUBSTANTIALLY CONFORMS TO THE APPROVED OR CONDITIONALLY APPROVED TENTATIVE MAP, IF ANY.

DATE: July 12, 2009

[Signature]  
EXPIRATION DATE: 12/31/09

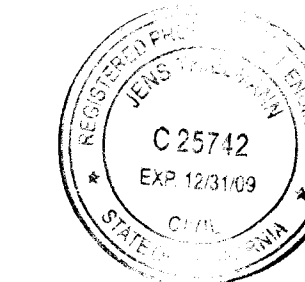

**CITY ENGINEER'S STATEMENT**

I HEREBY STATE THAT I HAVE EXAMINED THE WITHIN MAP; THAT THE SUBDIVISION AS SHOWN HEREON IS SUBSTANTIALLY THE SAME AS IT APPEARED ON THE VESTING TENTATIVE MAP OF PARCEL NO. 31368, BY THE BEAUMONT CITY COUNCIL ON JUNE 17, 2003, AND ANY APPROVED ALTERATION THEREOF; THAT ALL PROVISIONS OF THE SUBDIVISION MAP ACT AND OF TITLE 16 OF THE BEAUMONT MUNICIPAL CODE APPLICABLE AT THE TIME OF THE APPROVAL OF THE TENTATIVE MAP HAVE BEEN COMPLIED WITH; THAT I AM SATISFIED THAT THE MAP IS TECHNICALLY CORRECT; THAT PLANS FOR THE DRAINS, DRAINAGE WORKS AND SEWERS SUFFICIENT TO PROTECT ALL LOTS IN THE SUBDIVISION FROM FLOODS HAVE BEEN APPROVED; THAT A COMPLETE SET OF PLANS FOR THE CONSTRUCTION OF ALL REQUIRED IMPROVEMENTS HAS BEEN FILED WITH THE COMMUNITY DEVELOPMENT DEPARTMENT AND THAT THE SAME HAVE BEEN CHECKED AND APPROVED; AND THAT ALL IMPROVEMENTS HAVE BEEN COMPLETED IN ACCORDANCE WITH THE APPROVED PLANS OR THAT THE SUBDIVIDER HAS ENTERED INTO AGREEMENT WITH THE CITY OF BEAUMONT COVERING COMPLETION OF ALL IMPROVEMENTS AND SPECIFYING THE TIME FOR COMPLETING THE SAME AS MAY BE REQUIRED BY THE CONDITIONS OF APPROVAL DATED JUNE 17, 2003.

FOR: DEEPAK MOORJANI, R.C.E. 51047  
CITY ENGINEER, CITY OF BEAUMONT

DATED 15 JULY, 2009

[Signature]  
DENNIS WAYNE JANDA, L.S. 6359  
(LIC. EXPIRES 12/31/2010)

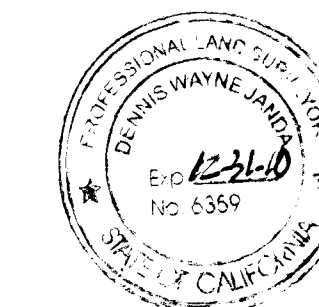

**BEAUMONT CITY COUNCIL CERTIFICATE**

I HEREBY CERTIFY THAT THIS MAP WAS APPROVED BY THE CITY OF BEAUMONT ON 6<sup>th</sup> DAY OF May, 2009, AND THAT THE OFFER(S) OF DEDICATION(S) DEPICTED HEREON WERE NOT ACCEPTED. THE CITY COUNCIL MAY, HOWEVER, BY RESOLUTION AT ANY LATER DATE, AND WITHOUT FURTHER ACTION BY THE SUBDIVIDER, RESCIND ITS ACTION AND ACCEPT THE FOLLOWING DEDICATION(S) AND IMPROVEMENTS FOR PUBLIC USE, WHICH ACCEPTANCE SHALL BE RECORDED IN THE OFFICE OF THE RIVERSIDE COUNTY RECORDER:

FOR STREET AND PUBLIC UTILITY PURPOSES PARCEL "A" - POTRERO BOULEVARD, PARCEL "C" - GEORGE LANE AND PARCEL "D" - GERALD WAY FOR SEWER LIFT STATION AND INCIDENTAL PURPOSES PARCEL "B".

DATED 7-20, 2009  
[Signature]  
CITY CLERK, CITY OF BEAUMONT  
RIVERSIDE COUNTY, CALIFORNIA

FOR SIGNATURE OMISSIONS SEE SHEET 2

IN THE CITY OF BEAUMONT, COUNTY OF RIVERSIDE, STATE OF CALIFORNIA

## PARCEL MAP NO. 31368

BEING A SUBDIVISION OF A PORTION OF SECTION 5, TOWNSHIP 3 SOUTH, RANGE 1 WEST, SAN BERNARDINO BASE AND MERIDIAN, AS SHOWN BY UNITED STATES GOVERNMENT SURVEY.

THIELMANN ENGINEERS

JANUARY 2008

NOTE:  
THIS MAP HAS BEEN RECORDED FOR FINANCING  
AND CONVEYANCE PURPOSES ONLY. NO USE IS  
PERMITTED WITHOUT ADDITIONAL CITY APPROVALS.

## SIGNATURE OMISSIONS:

PURSUANT TO SECTION 66436 OF THE SUBDIVISION MAP ACT, THE SIGNATURES OF THE FOLLOWING HAVE BEEN OMITTED:

RIGHT OF WAY EASEMENT TO JOHN H. LESLIE AND GEORGE H. LESLIE, AS TRUSTEES OF AND UNDER THAT LAST WILL AND TESTAMENT OF GEORGE LESLIE, DECEASED, BY DEED RECORDED IN BOOK 117 PAGE 202 OF DEEDS AS SHOWN HEREON.

EASEMENT TO SOUTHERN CALIFORNIA EDISON COMPANY FOR EITHER OR BOTH POLE LINES, CONDUITS, UNDERGROUND FACILITIES AND INCIDENTAL PURPOSES, RECORDED MAY 28, 1949 IN BOOK 1080, PAGE 235, O.R. AS SHOWN HEREON.

EASEMENT TO CALIFORNIA WATER AND TELEPHONE COMPANY, FOR EITHER OR BOTH POLE LINES, CONDUITS, UNDERGROUND FACILITIES AND INCIDENTAL PURPOSES, RECORDED SEPTEMBER 27, 1957 IN BOOK 2154, PAGE 64, O.R. AS SHOWN HEREON.

ABUTTER'S RIGHTS OF INGRESS AND EGRESS TO OR FROM THE FREEWAY RELINQUISHED IN THE DOCUMENT RECORDED FEBRUARY 13, 1958 IN BOOK 2221, PAGE 365, O.R.

EASEMENT TO FOUR CORNERS PIPE LINE COMPANY, FOR PIPE LINES, AND INCIDENTAL PURPOSES, RECORDED NOVEMBER 13, 1957 IN BOOK 2176, PAGE 511, O.R. NOT LOCATED OF RECORD.

EASEMENT TO SOUTHERN CALIFORNIA EDISON COMPANY, FOR EITHER OR BOTH POLE LINES, CONDUITS, UNDERGROUND FACILITIES AND INCIDENTAL PURPOSES, RECORDED JUNE 18, 1958 IN BOOK 2288, PAGE 351, O.R. AS SHOWN HEREON.

EASEMENT TO SOUTHERN CALIFORNIA EDISON COMPANY, FOR EITHER OR BOTH POLE LINES, CONDUITS, UNDERGROUND FACILITIES AND INCIDENTAL PURPOSES, RECORDED APRIL 10, 1964 AS INSTRUMENT NO. 44799, O.R. AS SHOWN HEREON.

EASEMENT TO CALIFORNIA WATER AND TELEPHONE COMPANY, FOR EITHER OR BOTH POLE LINES, CONDUITS OR UNDERGROUND FACILITIES AND INCIDENTAL PURPOSES, RECORDED NOVEMBER 2, 1966 AS INSTRUMENT NOS. 107533, 107534, 107535, 107536, 107537, 107538, 107539, 107540, 107541 AND 107542, O.R. AS SHOWN HEREON.

EASEMENT TO SOUTHERN CALIFORNIA EDISON COMPANY, FOR EITHER OF BOTH POLE LINES, CONDUITS OR UNDERGROUND FACILITIES AND INCIDENTAL PURPOSES, RECORDED MARCH 10, 1969 AS INSTRUMENT NO. 22834, O.R. AS SHOWN HEREON.

EASEMENT TO SOUTHERN CALIFORNIA EDISON COMPANY, FOR EITHER OR BOTH POLE LINES, CONDUITS, UNDERGROUND FACILITIES AND INCIDENTAL PURPOSES, RECORDED MAY 28, 1949 IN BOOK 1080, PAGE 229, O.R. AS SHOWN HEREON.

EASEMENT TO SOUTHERN CALIFORNIA EDISON COMPANY, FOR POLE LINES, CONDUITS OR UNDERGROUND FACILITIES AND INCIDENTAL PURPOSES, RECORDED APRIL 17, 1958 IN BOOK 2256, PAGE 459, O.R. AS SHOWN HEREON.

ABUTTER'S RIGHTS OF INGRESS AND EGRESS TO OR FROM THE FREEWAY RELINQUISHED IN THE DOCUMENT RECORDED SEPTEMBER 11, 1957 IN BOOK 2145, PAGE 506, O.R. AND BOOK 2145, PAGE 510, O.R.

EASEMENT TO CALIFORNIA WATER AND TELEPHONE COMPANY FOR A TELEPHONE LINE, CONSISTING OF POLES, NECESSARY GUYS AND ANCHORS, BRACES, CROSSARMS, WIRE, CONDUITS, CABLES, AND OTHER FIXTURES AND APPLIANCES, FOR CONVEYING ELECTRIC ENERGY TO BE USED FOR COMMUNICATION, TELEPHONE, TELEGRAPH AND/OR OTHER PURPOSES AND INCIDENTAL PURPOSES, RECORDED DECEMBER 16, 1957 IN BOOK 2193, PAGE 364, O.R. AS SHOWN HEREON. SAID DEED PROVIDES THAT THE GRANTEE, ITS SUCCESSORS AND ASSIGNS AND ITS AND THEIR RESPECTIVE AGENTS AND EMPLOYEES, SHALL HAVE THE RIGHT TO TRIM OR TOP SUCH TREES OR SHRUBS AS MAY ENDANGER OR INTERFERE WITH SAID TELEPHONE LINE, AND SHALL HAVE FREE ACCESS TO SAID TELEPHONE LINE AND EVERY PART THEREOF, AT ALL TIMES, FOR THE PURPOSES OF EXERCISING THE RIGHTS HEREIN GRANTED.

## SIGNATURE OMISSIONS continued:

EASEMENT TO SOUTHERN CALIFORNIA EDISON COMPANY, FOR EITHER OR BOTH POLE LINES, CONDUITS OR UNDERGROUND FACILITIES AND INCIDENTAL PURPOSES, RECORDED OCTOBER 31, 1958 IN BOOK 2357, PAGE 368, O.R. AS SHOWN HEREON.

EASEMENT TO ELMER D. SCHMIDT AND MOIRA M. SCHMIDT, FOR WATER LINES, WELL SITE, SEWER LINES AND INCIDENTAL PURPOSES, RECORDED JULY 25, 1977 AS INSTRUMENT NO. 140981, O.R. AS SHOWN HEREON.

EASEMENT TO GERALD AND FRANCES KAUSHANSKY AND JOHN A. AND KAY R. RINALDI, FOR WATER LINES, WELL SITE, AND INCIDENTAL PURPOSES, RECORDED FEBRUARY 10, 1978 AS INSTRUMENT NO. 26524, O.R. AS SHOWN HEREON.

EASEMENT TO CALIFORNIA WATER AND TELEPHONE COMPANY, FOR PUBLIC UTILITIES AND INCIDENTAL PURPOSES, RECORDED SEPTEMBER 20, 1957 IN BOOK 2151, PAGE 68, O.R. AS SHOWN HEREON.

ABUTTER'S RIGHTS OF INGRESS AND EGRESS TO OR FROM THE FREEWAY RELINQUISHED IN THE DOCUMENT RECORDED OCTOBER 11, 1957 IN BOOK 2161, PAGE 290, O.R.

EASEMENT TO SOUTHERN CALIFORNIA EDISON COMPANY, FOR PUBLIC UTILITIES AND INCIDENTAL PURPOSES, RECORDED OCTOBER 31, 1958 AS INSTRUMENT NO. 78596, FILED IN BOOK 2357, PAGE 367, O.R. AS SHOWN HEREON.

EASEMENT TO THE STATE OF CALIFORNIA FOR RIGHT OF WAY AND INCIDENTAL PURPOSES RECORDED OCTOBER 22, 1930 IN BOOK 877, PAGE 439 OF DEEDS. NOT LOCATED OF RECORD.

EASEMENT TO CALIFORNIA WATER AND TELEPHONE COMPANY, FOR PUBLIC UTILITIES AND INCIDENTAL PURPOSES, RECORDED NOVEMBER 2, 1966 AS INSTRUMENT NO. 107530, O.R. AS SHOWN HEREON.

EASEMENT TO ALBERT LOGAN OXFORD, JR. FOR PIPELINES AND INCIDENTAL PURPOSES, RECORDED APRIL 4, 1939 IN BOOK 412, PAGE 385, O.R. AS SHOWN HEREON.

EASEMENT TO COUNTY OF RIVERSIDE FOR ROAD AND INCIDENTAL PURPOSES, RECORDED OCTOBER 29, 1915 IN BOOK 433, PAGE 7 OF DEEDS. NOT LOCATED OF RECORD.

# PARCEL MAP NO. 31368

BEING A SUBDIVISION OF A PORTION OF SECTION 5, TOWNSHIP 3 SOUTH, RANGE 1 WEST, SAN BERNARDINO BASE AND MERIDIAN, AS SHOWN BY UNITED STATES GOVERNMENT SURVEY.

THIELMANN ENGINEERS JANUARY 2008

NOTE:  
THIS MAP HAS BEEN RECORDED FOR FINANCING AND CONVEYANCE PURPOSES ONLY. NO USE IS PERMITTED WITHOUT ADDITIONAL CITY APPROVALS.

**EASEMENT NOTES:**

- 1 INDICATES A RIGHT OF WAY EASEMENT TO JOHN H. LESLIE AND GEORGE H. LESLIE, AS TRUSTEES OF AND UNDER THAT LAST WILL AND TESTAMENT OF GEORGE LESLIE, DECEASED, BY DEED RECORDED. IN BOOK 117 PAGE 202 OF DEEDS AS SHOWN HEREON.
- 2 INDICATES AN EASEMENT TO SOUTHERN CALIFORNIA EDISON COMPANY, LTD. FOR POLE LINES, CONDUITS, UNDERGROUND FACILITIES AND INCIDENTAL PURPOSES, REC. MAY 28, 1949 IN BOOK 1080, PAGE 235, O.R. AS SHOWN HEREON.
- 3 INDICATES AN EASEMENT TO CALIFORNIA WATER AND TELEPHONE COMPANY, FOR EITHER OR BOTH POLE LINES, CONDUITS, UNDERGROUND FACILITIES AND INCIDENTAL PURPOSES, RECORDED SEPTEMBER 27, 1957 IN BOOK 2154, PAGE 64, O.R. AS SHOWN HEREON.
- 4 INDICATES AN EASEMENT TO SOUTHERN CALIFORNIA EDISON COMPANY, FOR PUBLIC UTILITIES AND INCIDENTAL PURPOSES, RECORDED OCTOBER 31, 1958 AS INSTRUMENT NO. 78596, FILED IN BOOK 2357, PAGE 367, O.R. AS SHOWN HEREON.
- 5 INDICATES AN EASEMENT TO SOUTHERN CALIFORNIA EDISON COMPANY, FOR EITHER OR BOTH POLE LINES, CONDUITS, UNDERGROUND FACILITIES AND INCIDENTAL PURPOSES, RECORDED JUNE 18, 1958 IN BOOK 2288, PAGE 351, O.R. AS SHOWN HEREON.
- 6 INDICATES AN EASEMENT TO SOUTHERN CALIFORNIA EDISON COMPANY, FOR EITHER OR BOTH POLE LINES, CONDUITS, UNDERGROUND FACILITIES AND INCIDENTAL PURPOSES, RECORDED APRIL 10, 1964 AS INSTRUMENT NO. 44799, O.R. AS SHOWN HEREON.
- 7 INDICATES AN EASEMENT TO CALIFORNIA WATER AND TELEPHONE COMPANY, FOR EITHER OR BOTH POLE LINES, CONDUITS OR UNDERGROUND FACILITIES AND INCIDENTAL PURPOSES, RECORDED NOVEMBER 2, 1966 AS INSTRUMENT NOS. 107533, 107534, 107535, 107536, 107537, 107538, 107539, 107540, 107541 AND 107542, O.R. AS SHOWN HEREON.
- 8 INDICATES AN EASEMENT TO SOUTHERN CALIFORNIA EDISON COMPANY, FOR EITHER OF BOTH POLE LINES, CONDUITS OR UNDERGROUND FACILITIES AND INCIDENTAL PURPOSES, RECORDED MARCH 10, 1969 AS INSTRUMENT NO. 22834, O.R. AS SHOWN HEREON.
- 9 INDICATES AN EASEMENT TO THE CITY OF BEAUMONT, FOR PUMP STATION AND SANITARY SEWER PIPELINE FACILITIES AND INCIDENTAL PURPOSES, RECORDED DECEMBER 1, 1972 AS INSTRUMENT NO. 159871, O.R. AS SHOWN HEREON.
- 10 INDICATES AN OFFER OF DEDICATION TO THE CITY OF BEAUMONT FOR PUBLIC ROAD, UTILITY AND PUBLIC SERVICES AND INCIDENTAL PURPOSES, RECORDED AUGUST 16, 1974 AS INSTRUMENT NO. 105632, O.R. AS SHOWN HEREON.
- 11 INDICATES AN OFFER OF DEDICATION TO THE CITY OF BEAUMONT, FOR OAK VALLEY PARKWAY SEWER AND POTRERO BOULEVARD RIGHT OF WAY AND INCIDENTAL PURPOSES RECORDED APRIL 3, 2007 AS INSTRUMENT NO. 2007-0225317, O.R. AS SHOWN HEREON.
- 12 INDICATES AN OFFER OF DEDICATION TO THE CITY OF BEAUMONT, FOR SEWER LIFT STATION AND INCIDENTAL PURPOSES RECORDED MAY 7, 2007 AS INSTRUMENT NO. 2007-0304695, O.R. AS SHOWN HEREON.
- 13 INDICATES AN EASEMENT TO SOUTHERN CALIFORNIA EDISON COMPANY, FOR EITHER OR BOTH POLE LINES, CONDUITS, UNDERGROUND FACILITIES AND INCIDENTAL PURPOSES, RECORDED MAY, 28, 1949 IN BOOK 1080, PAGE 229, O.R. AS SHOWN HEREON.
- 14 EASEMENT TO CALIFORNIA WATER AND TELEPHONE COMPANY FOR A TELEPHONE LINE, CONSISTING OF POLES, NECESSARY GUYS AND ANCHORS, BRACES, CROSSARMS, WIRE, CONDUITS, CABLES, AND OTHER FIXTURES AND APPLIANCES, FOR CONVEYING ELECTRIC ENERGY TO BE USED FOR COMMUNICATION, TELEPHONE, TELEGRAPH AND/OR OTHER PURPOSES AND INCIDENTAL PURPOSES, RECORDED DECEMBER 16, 1957 IN BOOK 2193, PAGE 364, O.R. AS SHOWN HEREON. SAID DEED PROVIDES THAT THE GRANTEE, ITS SUCCESSORS AND ASSIGNS AND ITS AND THEIR RESPECTIVE AGENTS AND EMPLOYEES, SHALL HAVE THE RIGHT TO TRIM OR TOP SUCH TREES OR SHRUBS AS MAY ENDANGER OR INTERFERE WITH SAID TELEPHONE LINE, AND SHALL HAVE FREE ACCESS TO SAID TELEPHONE LINE AND EVERY PART THEREOF, AT ALL TIMES, FOR THE PURPOSES OF EXERCISING THE RIGHTS HEREIN GRANTED.
- 15 INDICATES AN EASEMENT TO SOUTHERN CALIFORNIA EDISON COMPANY, FOR EITHER OR BOTH POLE LINES, CONDUITS OR UNDERGROUND FACILITIES AND INCIDENTAL PURPOSES, RECORDED APRIL 17, 1958 IN BOOK 2256, PAGE 459, O.R. AS SHOWN HEREON.
- 16 INDICATES AN EASEMENT TO SOUTHERN CALIFORNIA EDISON COMPANY, FOR EITHER OR BOTH POLE LINES, CONDUITS OR UNDERGROUND FACILITIES AND INCIDENTAL PURPOSES, RECORDED OCTOBER 31, 1958 AS INSTRUMENT NO. 78596 IN BOOK 2357, PAGE 368, O.R. AS SHOWN HEREON.
- 17 INDICATES AN EASEMENT TO ELMER D. SCHMIDT AND MOIRA M. SCHMIDT, FOR WATER LINES, WELL SITE, SEWER LINES AND INCIDENTAL PURPOSES, RECORDED JULY 25, 1977 AS INSTRUMENT NO. 140981, O.R. AS SHOWN HEREON.
- 18 INDICATES AN EASEMENT TO GERALD AND FRANCES KAUSHANSKY AND JOHN A. AND KAY R. RINALDI, FOR WATER LINES, WELL SITE, AND INCIDENTAL PURPOSES, RECORDED FEBRUARY 10, 1978 AS INSTRUMENT NO. 26524, O.R. AS SHOWN HEREON.

**EASEMENT NOTES: (CONTINUED)**

- 19 INDICATES AN EASEMENT TO CALIFORNIA WATER AND TELEPHONE COMPANY, FOR PUBLIC UTILITIES AND INCIDENTAL PURPOSES, RECORDED SEPTEMBER 20, 1957 IN BOOK 2151, PAGE 68, O.R. AS SHOWN HEREON.
- 20 EASEMENT TO CALIFORNIA WATER AND TELEPHONE COMPANY, FOR PUBLIC UTILITIES AND INCIDENTAL PURPOSES, RECORDED NOVEMBER 2, 1966 AS INSTRUMENT NO. 107530, O.R. AS SHOWN HEREON.
- 21 EASEMENT TO ALBERT LOGAN OXFORD, JR. FOR PIPELINES AND INCIDENTAL PURPOSES, RECORDED APRIL 4, 1939 IN BOOK 412, PAGE 385, O.R. AS SHOWN HEREON.
- 22 EASEMENT TO THE CITY OF BEAUMONT FOR PUBLIC ROAD AND DRAINAGE AND INCIDENTAL PURPOSES, RECORDED MARCH 14, 1985 AS INSTRUMENT NO. 85-52551, O.R. AS SHOWN HEREON.

**FOUND MONUMENT DESCRIPTIONS**

- 1 FD 3/4" IRON PIPE, DOWN 0.2', TAGGED "LS 6054" PER RS 85/20-25, ACCEPTED AS SW COR. SEC 5, T. 3 S., R. 1 W.
- 2 FD 1" IRON PIPE, DOWN 0.3', ILLEGIBLE, PER RS 85/20-25, RS 56/78, ACCEPTED AS S 1/4 COR. SEC 5, T. 3 S., R. 1 W.
- 3 FD 2" IRON PIPE, WITH BOLT SPIKE, FLUSH, IN LIEU OF 1/2" IP PER RS 17/21, ACCEPTED AS SE COR. SEC. 5 T. 3 S., R. 1 W.
- 4 SEARCHED, FD. NOTHING. EST. W 1/4 COR. SEC 5, T. 3 S., R. 1 W. BY SINGLE PROPORTION. SET 8" SPIKE AND WASHER, RCE 25742, FLUSH.
- 5 FD. 1" IRON PIPE, WITH PLASTIC PLUG LS 7754, FLUSH, PER RS 114/46, ACCEPTED AS NE COR. DEED RECORDED JUNE 16, 1987 AS INSTRUMENT NO. 204823 PER RS 114/46.
- 6 SEARCHED, FD. NOTHING. EST. POINT ON RR R/W E.C. BY EXTENDING TANGENT FROM RECORD EC PER RS 80/78-89. SET 1" IRON PIPE TAG RCE 25742, FLUSH.
- 7 FD. BRASS CAP IN CONC. DN. 0.2', MARKED CAL. DIV. HWYS 1/4 COR. S. 4 AND S. 5" PER RS 80/78-89.
- 8 FD 3/4" IRON PIPE, DOWN 0.2', TAGGED "RCE 9876", PER RS 17/21, RS 80/78-89, RS 109/7-13, ACCEPTED AS POINT OF WEST LINE OF THE E 1/2 OF SEC 5, T. 3 S., R. 1 W.
- 9 SEARCHED, FD. NOTHING. SET 1" IRON PIPE TAGGED RCE 25742, FLUSH, AT POINT ON SECTION LINE PER RS 80/78-89.
- 10 FD 1" IRON PIPE, FLUSH, TAGGED "LS 3018", PER RS 80/78-89, ACCEPTED AS POINT ON SECTION LINE SURVEY AND MONUMENTATION LINE.
- 11 SEARCHED, FD. NOTHING. SET 1" IRON PIPE TAGGED RCE 25742, FLUSH, AT NE CORNER OF SOUTH 695 FEET OF EAST 2050 FEET OF SE 1/4 SEC. 5, T. 3 S., R. 1 W.
- 12 FD 1" IRON PIPE TAGGED "LS 3018," FLUSH, PER RS 80/78-89, ACCEPTED AS INTERSECTION OF S'LY LINE OF S.P.R.R. R/W AND E LINE OF NW 1/4 OF SEC 5, T. 3 S., R. 1 W. TIE TO CALIFORNIA STATE PLANE COORDINATE SYSTEM, 1983, ZONE 6 PER RS 109/7-13, BEING N2287891.27, E6331734.15.
- 13 SEARCHED, FD. NOTHING. SET 1" IRON PIPE TAGGED RCE 25742, FLUSH.
- 14 FD. 1" IRON PIPE, TAGGED LS 3018, FLUSH, PER RS 109/7-13. ACCEPTED AS PCC, SO. PACIFIC RR R/W.
- 15 FD. 1" IRON PIPE, TAGGED LS 3018, FLUSH, S 39°00'00" E 0.13' OF INTERSECTION OF SW'LY LINE OF SO. PACIFIC RR R/W AND CENTERLINE SEC 5, T. 3 S., R. 1 W., PER RS 109/7-13. ACCEPTED AS POINT ON LINE OF SO. PACIFIC RR R/W. TIE TO CALIFORNIA STATE PLANE COORDINATE SYSTEM, 1983, ZONE 6 PER RS 109/7-13, BEING N2287028.79, E6333900.95.
- 16 SEARCHED, FD. NOTHING. EST. POINT ON RR R/W E.C. PER R.S. 109/7-10. SET 1" IRON PIPE TAG RCE 25742, FLUSH.
- 17 FD. 2" IRON PIPE, FLUSH, NO REF. S 88° 39' 21" E, 0.18' OF E'LY LINE SEC. 5, T. 3 S., R. 1 W. HELD FOR N'LY LINE OF SOUTH 695 FEET OF EAST 2050 FEET OF SE 1/4 SEC. 5, T. 3 S., R. 1 W.
- 18 FD. 1" IRON PIPE, WITH PLASTIC PLUG LS 7754, FLUSH, PER RS 114/46, S 27° 43' E, 0.21', NOT ACCEPTED.

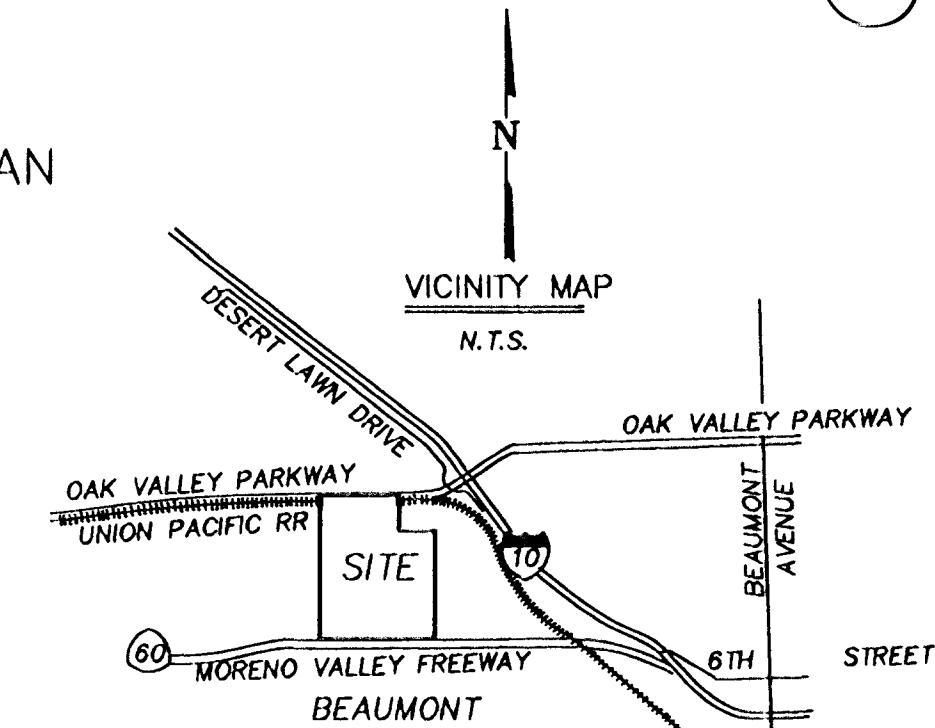

**BASIS OF BEARINGS**

THE BEARINGS SHOWN HEREON ARE BASED UPON THE NORTHERLY LINE OF THE NORTHWEST 1/4 OF SECTION 8, T. 3 S., R. 1 W. S.B.B.M. ACCORDING TO MAP, FILED IN BOOK 85, PAGES 20-25 OF RECORD OF SURVEY, RECORDS OF RIVERSIDE COUNTY, CALIFORNIA, AND BEING: NORTH 89° 06' 52" WEST.

**SURVEYOR'S NOTES**

- INDICATES SET 1" IRON PIPE TAGGED R.C.E 25742, FLUSH.
- SET 1" IRON PIPE TAGGED R.C.E 25742, FLUSH AT ALL PARCEL BOUNDARY CORNERS, STREET CENTERLINE INTERSECTIONS, B.C.'S, E.C.'S, AND ALL OTHER CENTERLINE POINTS OF CONTROL UNLESS OTHERWISE NOTED.
- ALL MONUMENTS SHOWN AS, "SET" SHALL BE IN ACCORDANCE WITH THE TERMS OR THE MONUMENTATION AGREEMENT FOR THIS MAP, UNLESS OTHERWISE NOTED.
- INDICATES FOUND AS NOTED. FOR SIZE AND DESCRIPTION SEE DESCRIPTION NUMBER.
- ▲ INDICATES TIE TO CALIFORNIA STATE PLANE COORDINATE SYSTEM NAD 1983, ZONE 6 PER RS 109/7-13. FOUND MONUMENT AS NOTED. FOR SIZE AND DESCRIPTION AND COORDINATES, SEE DESCRIPTION NUMBER.
- ADDITIONAL STATE PLANE DATA PER RS 109/7-13 LISTED AS FOLLOWS:  
COMBINATION FACTOR 0.999904925  
SCALE FACTOR 1.00001314
- ① INDICATES MONUMENT DESCRIPTION NUMBER. SEE "FOUND MONUMENT DESCRIPTIONS" THIS SHEET.
- (R1) INDICATES RECORD DATA PER RECORD OF SURVEY, RS 17/21
- (R2) INDICATES RECORD DATA PER RECORD OF SURVEY, RS 85/20-25
- (R3) INDICATES RECORD DATA PER RECORD OF SURVEY, RS 80/78-89
- (R4) INDICATES RECORD DATA PER RECORD OF SURVEY, RS 109/7-13
- (R5) INDICATES RECORD DATA PER CALTRANS R/W MAP 428583, CO. SURV. MAP 204/159-160.
- (R6) INDICATES RECORD DATA PER TRACT NO. 31288-5, MB 425/52-64
- (R7) INDICATES RECORD DATA PER INST. NO. 2007-0225317, O.R.

**EASEMENT DETAIL NOTES**

- EASEMENTS NO. 1 AND 8 - SEE DETAIL "D" SHEET 5
- EASEMENT NO. 2 - SEE DETAIL "H" SHEET 6
- EASEMENT NO. 3 - SEE DETAIL "A" SHEET 5
- EASEMENT NO. 4 - SEE DETAIL "J" SHEET 6
- EASEMENT NO. 6 AND 11 - SEE DETAIL "L" SHEET 7
- EASEMENT NO. 5 - SEE DETAIL "B" SHEET 5
- EASEMENT NO. 7 - SEE DETAIL "C" SHEET 5
- EASEMENT NO. 9 - SEE DETAILS "O" AND "P" SHEET 7
- EASEMENT NO. 10 - SEE DETAIL "E" SHEET 5
- EASEMENT NO. 12 - SEE DETAIL "M" SHEET 7
- EASEMENT NO. 13 AND 18 - SEE DETAIL "G" SHEET 5
- EASEMENT NO. 14 - SEE DETAIL "F" SHEET 5
- EASEMENT NO. 16, 17 AND 18 - SEE DETAIL "N" SHEET 7
- EASEMENT NO. 19 - SEE DETAIL "I" SHEET 6
- EASEMENT NO. 21 - SEE DETAIL "Q" SHEET 6
- EASEMENT NO. 22 - SEE DETAIL "R" AND "S" SHEET 5

City  
229  
48

NOTE:  
THIS MAP HAS BEEN RECORDED FOR FINANCING  
AND CONVEYANCE PURPOSES ONLY. NO USE IS  
PERMITTED WITHOUT ADDITIONAL CITY APPROVALS.

SEE SHEET 3 FOR EASEMENT NOTES, FOUND  
MONUMENT DESCRIPTIONS, BASIS OF BEARINGS  
NOTE, SURVEYOR'S NOTES.

IN THE CITY OF BEAUMONT, COUNTY OF RIVERSIDE, STATE OF CALIFORNIA  
**PARCEL MAP NO. 31368**

BEING A SUBDIVISION OF A PORTION OF SECTION 5, TOWNSHIP 3 SOUTH, RANGE 1 WEST, SAN BERNARDINO BASE AND  
MERIDIAN, AS SHOWN BY UNITED STATES GOVERNMENT SURVEY.

THIELMANN ENGINEERS JANUARY 2008

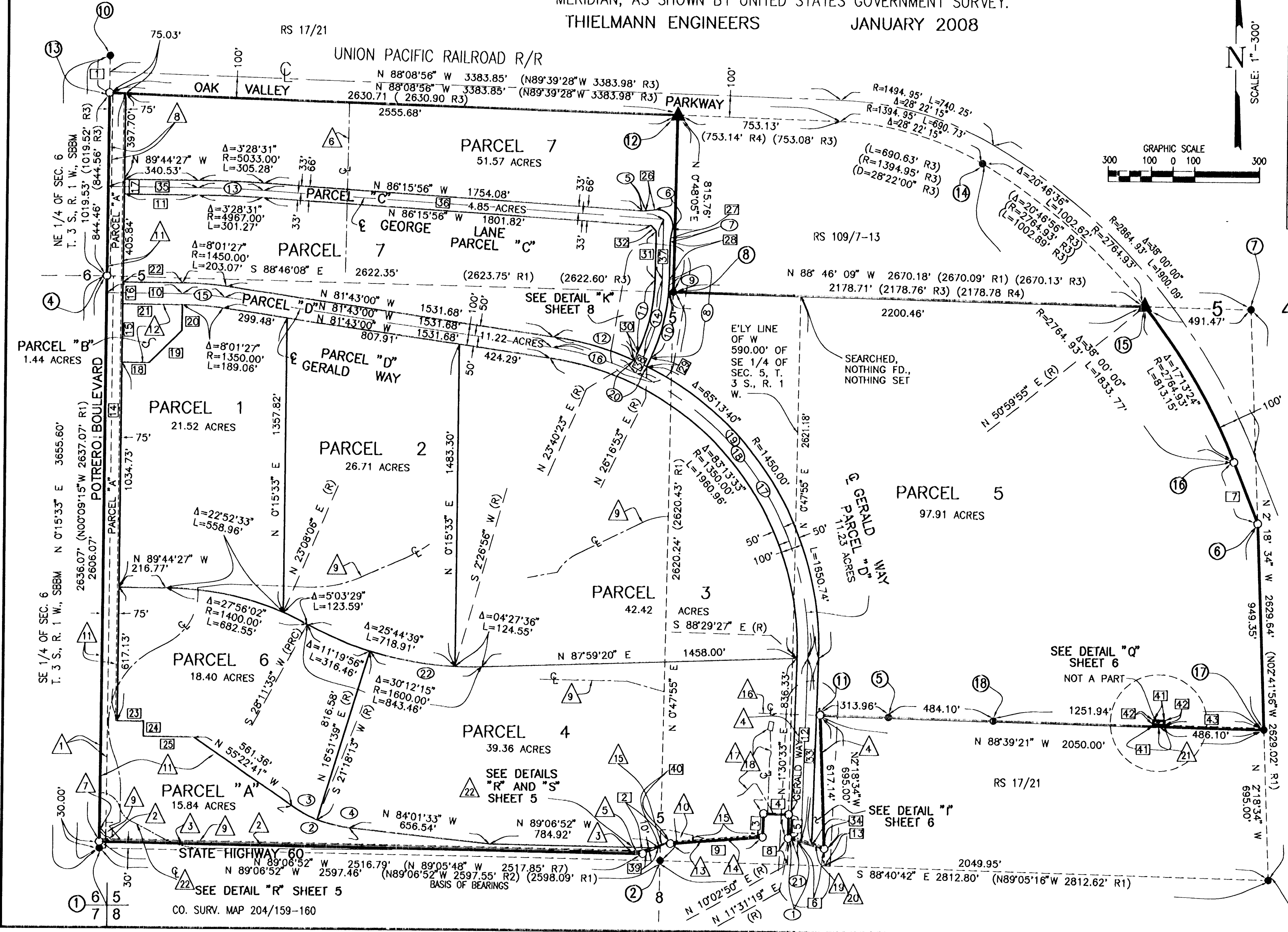

CURVE DATA

CURVE	DELTA	RADIUS	LENGTH
1	06°08'49"	425.00'	45.60'
2	28°38'52"	570.00'	285.00'
3	13°19'06"	570.00'	132.50'
4	15°19'46"	570.00'	152.50'
5	10°08'58"	100.00'	17.71'
6	10°21'56"	76.00'	142.42'
7	10°08'57"	100.00'	17.71'
8	24°10'33"	883.00'	372.58'
9	03°36'34"	883.00'	55.63'
10	20°33'59"	883.00'	316.95'
11	24°10'33"	817.00'	344.73'
12	15°23'23"	1450.00'	389.47'
13	3°28'31"	5000.00'	303.28'
14	24°10'33"	850.00'	358.66'
15	8°01'27"	1400.00'	196.07'
16	16°41'38"	1400.00'	407.91'
17	66°31'55"	1400.00'	1625.68'
18	83°13'33"	1400.00'	2033.59'
19	83°13'33"	1450.00'	2106.22'
20	2°36'30"	1450.00'	66.01'
21	4°40'20"	425.00'	34.66'
22	18°52'19"	1600.00'	527.00'

LINE TABLE

LINE	BEARING	DISTANCE
1	N 0°15'33" E	175.07'
1	(N 0°14'53" E 175.07') (R3)	
2	N 69°17'20" E	136.58'
3	N 1°57'41" E	107.58'
4	N 88°18'21" W	116.62'
5	N 0°47'55" E	108.44'
6	N 7°48'21" W	128.65'
7	N 2°14'41" W	302.36'
8	N 0°47'55" E	120.86'
9	N 85°41'35" E	426.80'
10	N 89°44'27" W	351.00'
11	N 89°44'27" W	340.53'
12	N 1°30'33" E	847.98'
13	N 2°18'34" W	77.86'
14	N 0°15'33" E	2889.40'
15	N 0°15'33" E	268.00'
16	N 0°15'33" E	100.00'
17	N 0°15'33" E	66.00'
18	N 89°44'27" W	126.00'
19	N 45°15'33" E	212.13'
20	N 0°15'33" E	118.00'
21	N 89°44'27" W	276.00'
22	N 89°44'27" W	276.00'
23	N 89°44'27" W	121.86'
24	N 0°14'41" E	70.00'
25	N 89°45'19" W	229.36'
26	N 83°35'06" E	41.12'
27	N 10°57'02" E	41.12'
28	N 0°48'05" E	175.18'
29	N 24°58'38" E	42.59'
30	N 24°58'38" E	42.59'
31	N 0°48'05" E	222.92'
32	S 42°43'56" E	34.44'
33	N 1°30'33" E	861.08'
34	N 7°48'21" W	60.26'
35	N 89°44'27" W	415.53'
36	N 86°15'56" W	1856.92'
37	N 0°48'05" E	278.02'
38	N 24°58'38" E	92.21'
39	N 69°17'20" E	81.51'
40	N 69°17'20" E	55.07'
41	N 88°40'42" W	50.00'
42	N 1°19'18" E	20.00'
43	N 88°40'42" W	460.77'

NOTE:  
THIS MAP HAS BEEN RECORDED FOR FINANCING  
AND CONVEYANCE PURPOSES ONLY. NO USE IS  
PERMITTED WITHOUT ADDITIONAL CITY APPROVALS.

# IN THE CITY OF BEAUMONT, COUNTY OF RIVERSIDE, STATE OF CALIFORNIA PARCEL MAP NO. 31368

BEING A SUBDIVISION OF A PORTION OF SECTION 5, TOWNSHIP 3 SOUTH, RANGE 1 WEST, SAN BERNARDINO BASE AND  
MERIDIAN, AS SHOWN BY UNITED STATES GOVERNMENT SURVEY.

THIELMANN ENGINEERS JANUARY 2008

SEE SHEET 3 FOR EASEMENT NOTES, FOUND  
MONUMENT DESCRIPTIONS, BASIS OF BEARINGS  
NOTE, SURVEYOR'S NOTES.

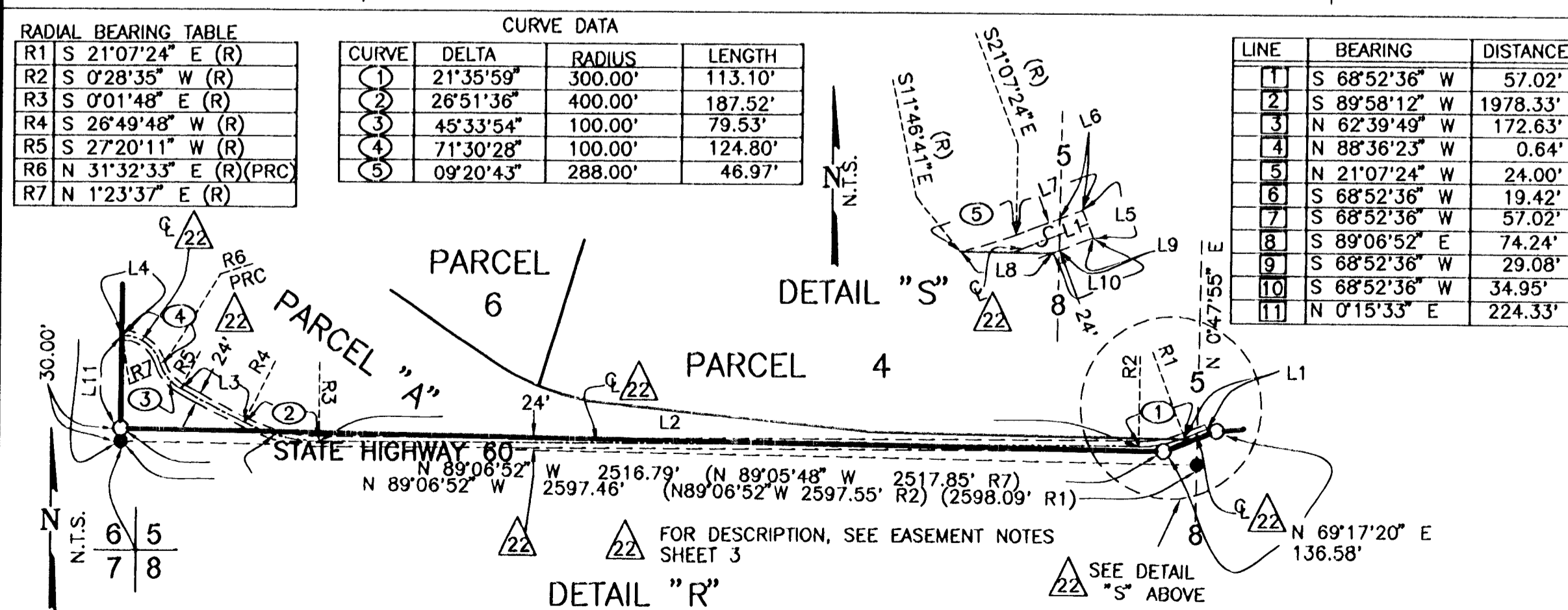
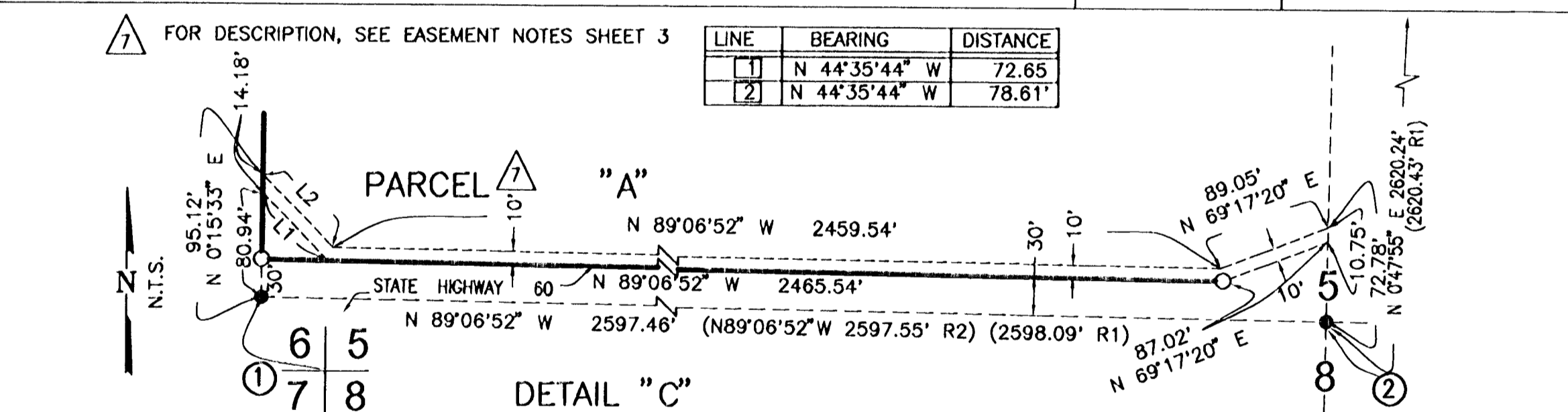
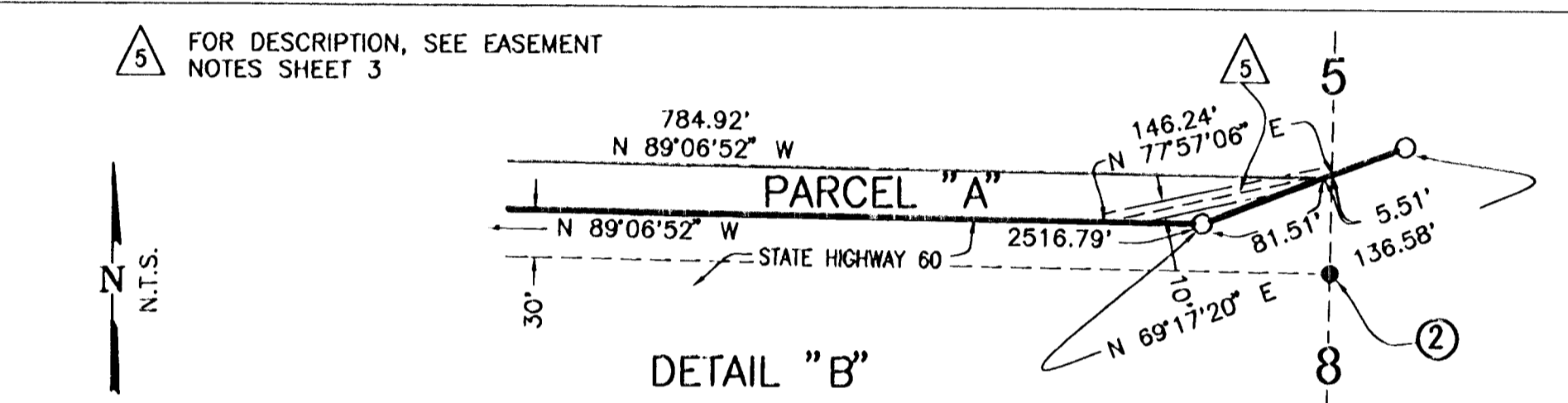
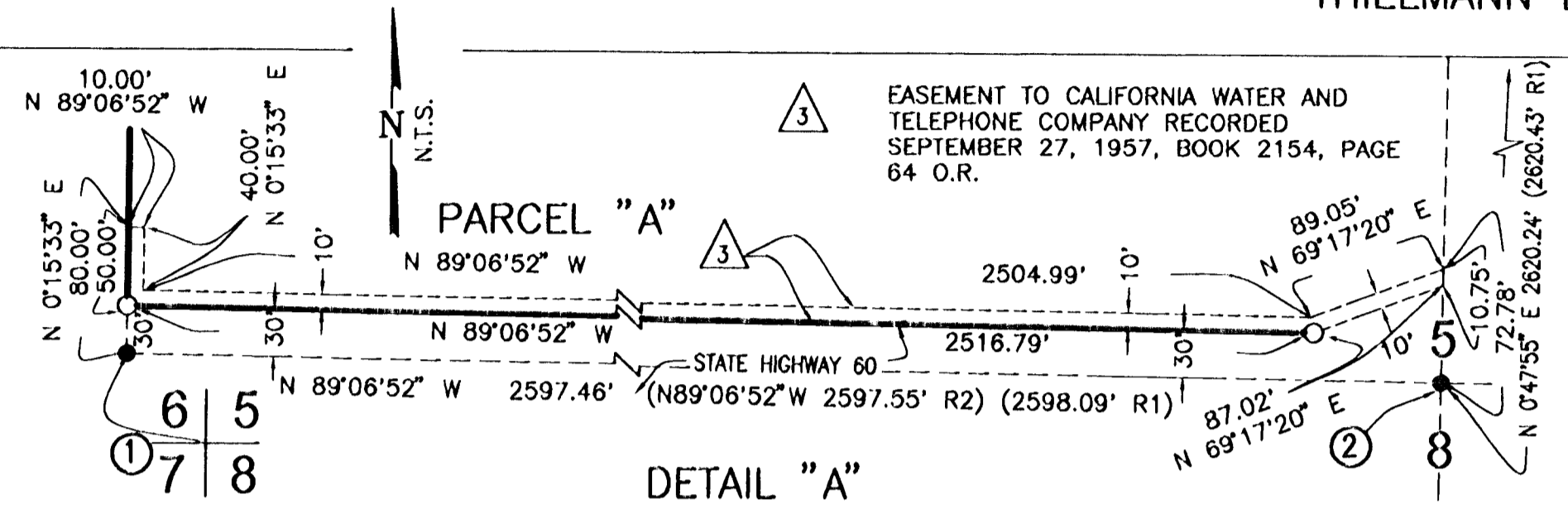

DETAIL SHEET

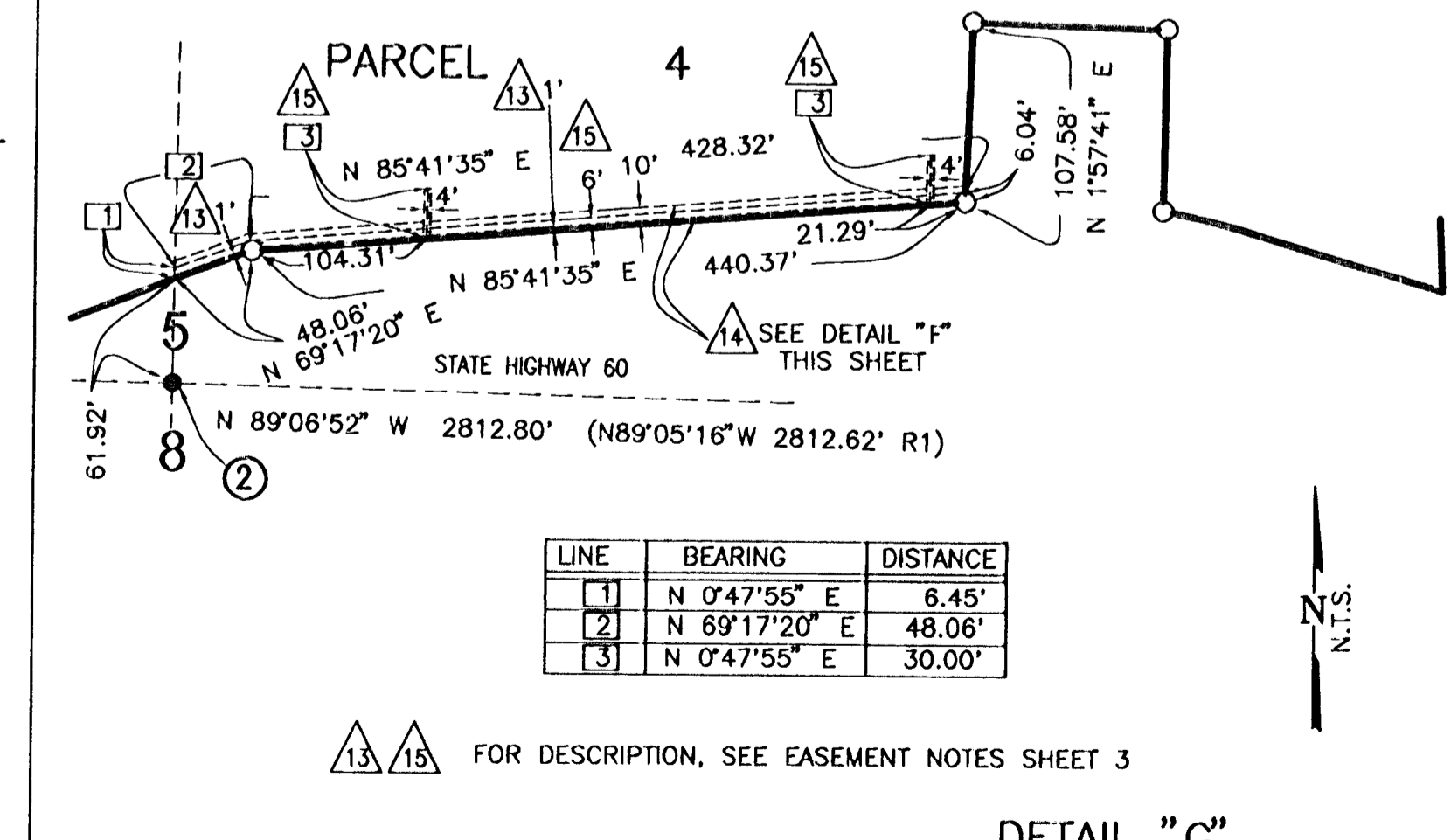
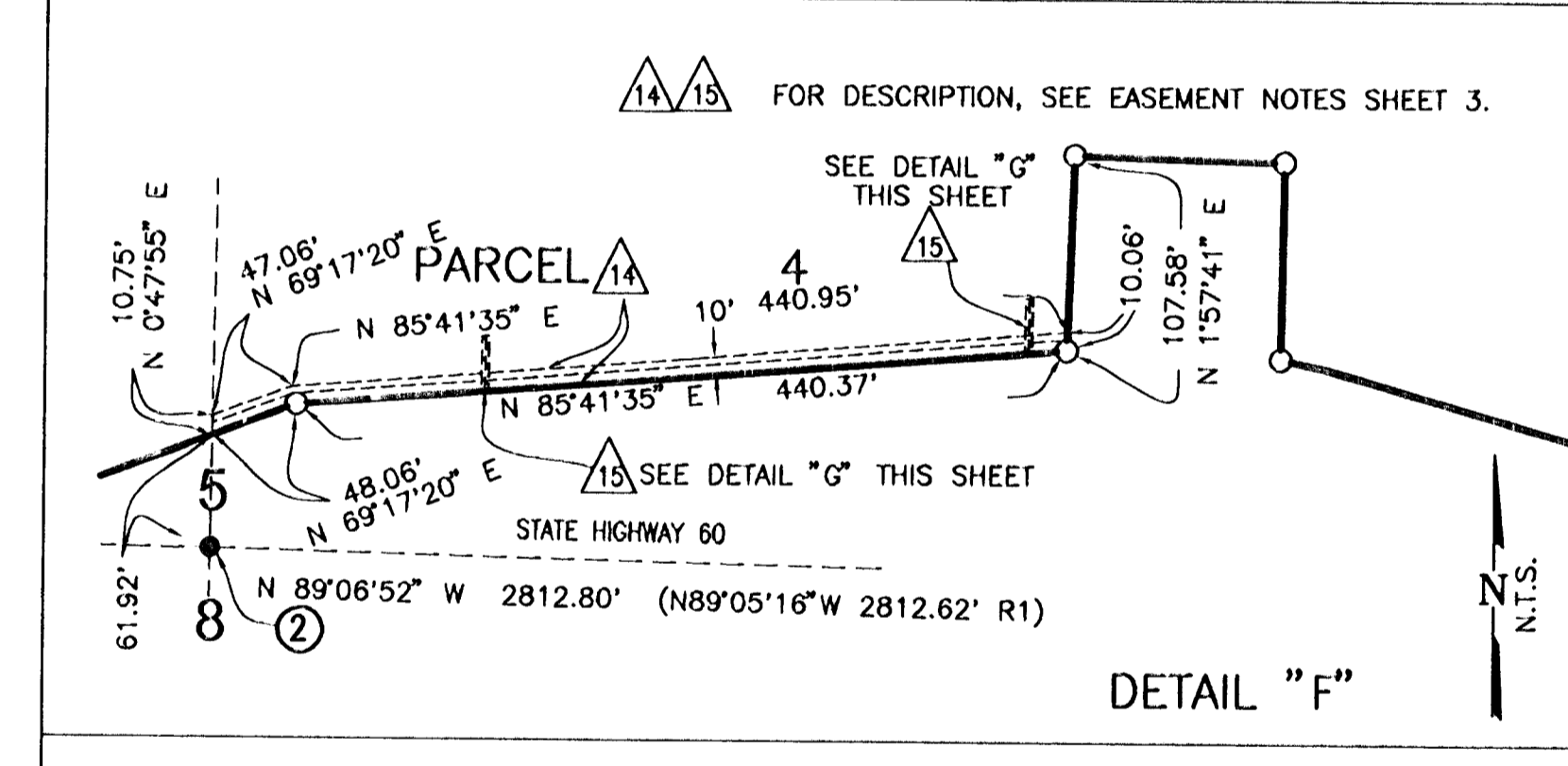
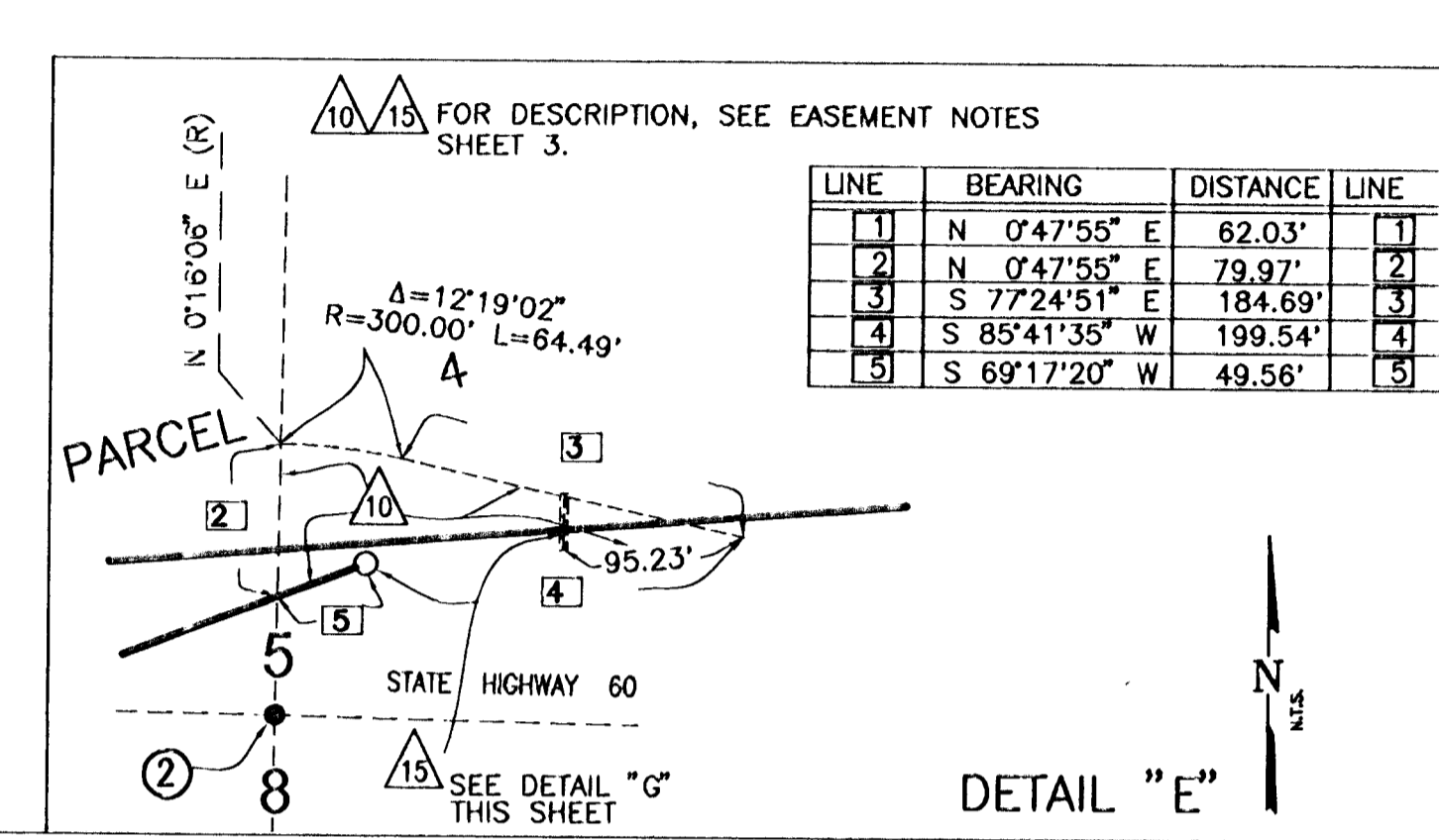
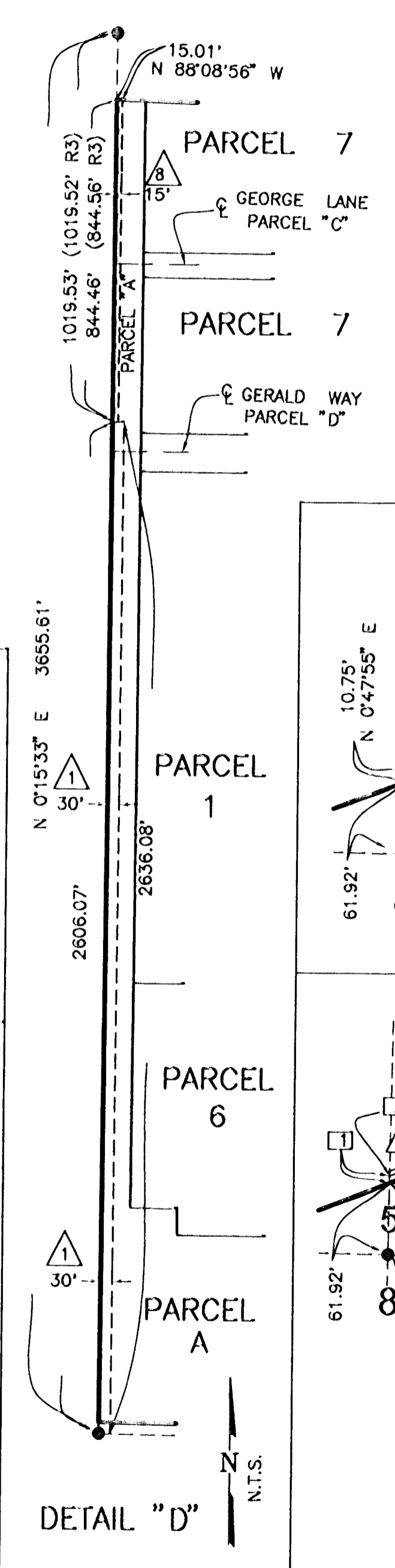

# PARCEL MAP NO. 31368

NOTE:  
THIS MAP HAS BEEN RECORDED FOR FINANCING  
AND CONVEYANCE PURPOSES ONLY. NO USE IS  
PERMITTED WITHOUT ADDITIONAL CITY APPROVALS.

SEE SHEET 3 FOR EASEMENT NOTES, FOUND MONUMENT  
DESCRIPTIONS, BASIS OF BEARINGS NOTE, SURVEYOR'S NOTES. BEING A SUBDIVISION OF A PORTION OF SECTION 5, TOWNSHIP 3 SOUTH, RANGE 1 WEST, SAN BERNARDINO BASE AND  
MERIDIAN, AS SHOWN BY UNITED STATES GOVERNMENT SURVEY.

THIELMANN ENGINEERS JANUARY 2008

DETAIL SHEET

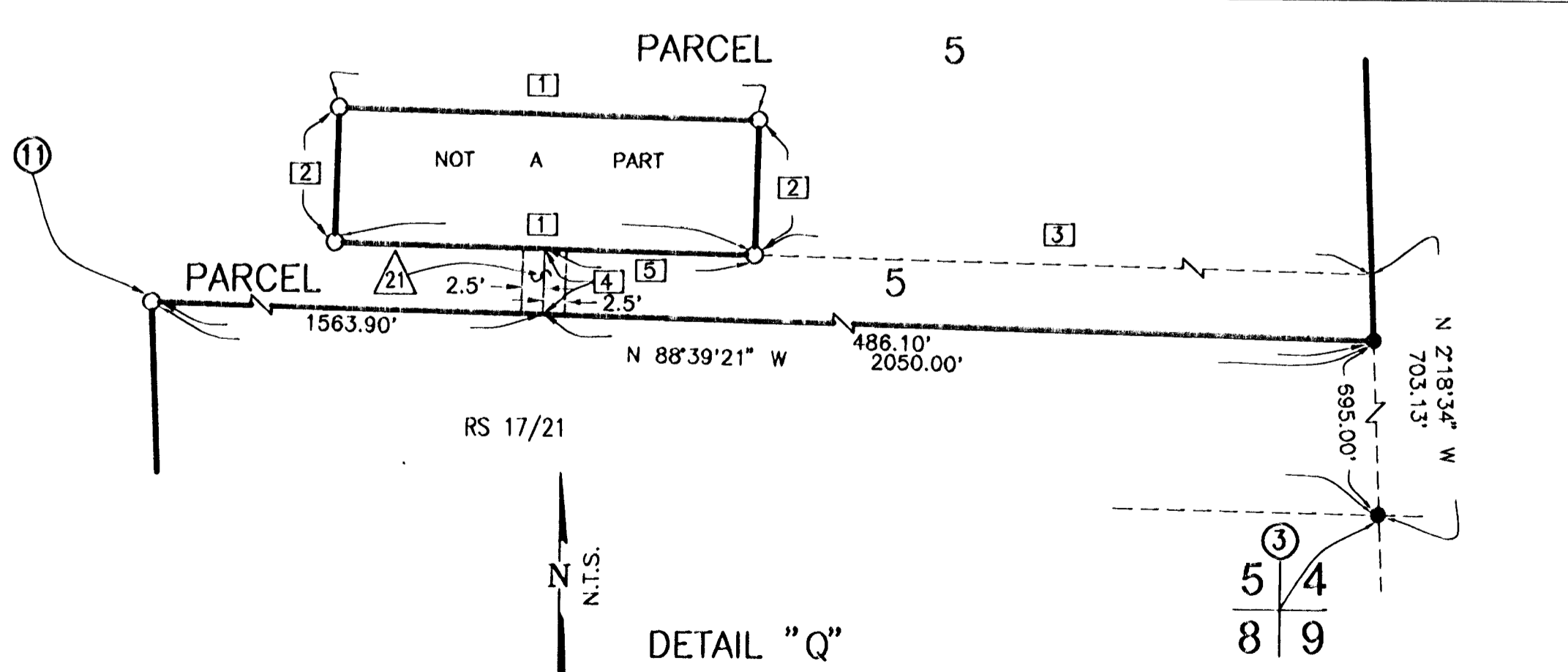
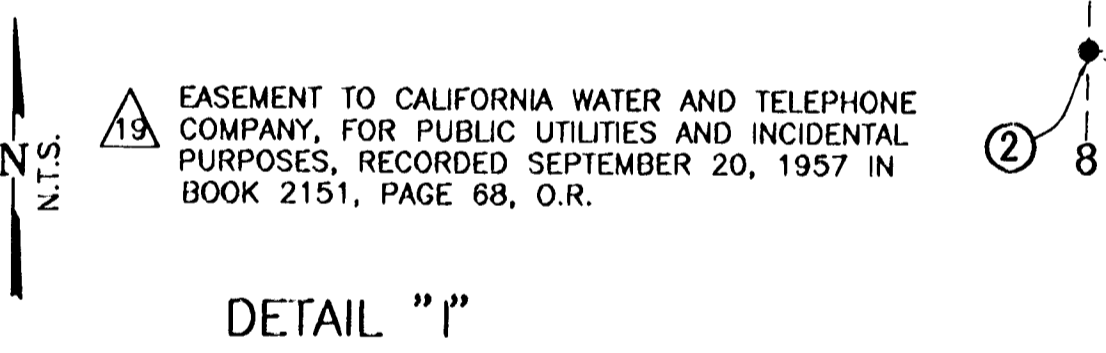
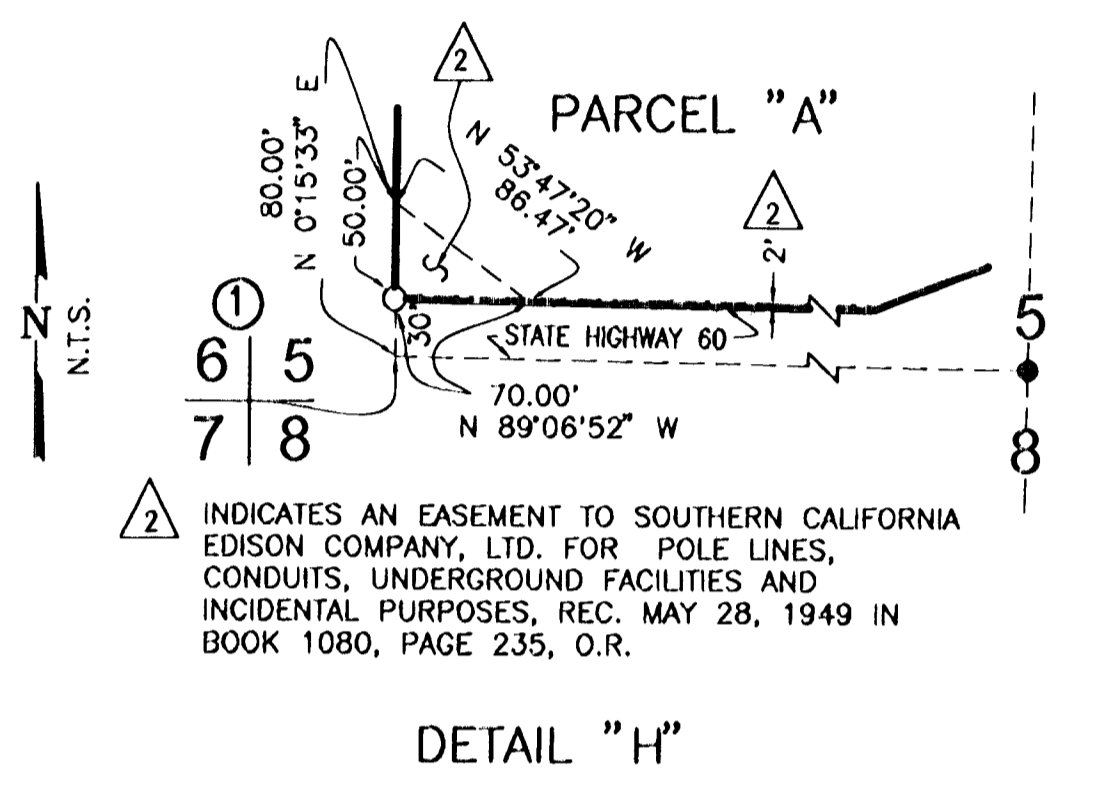
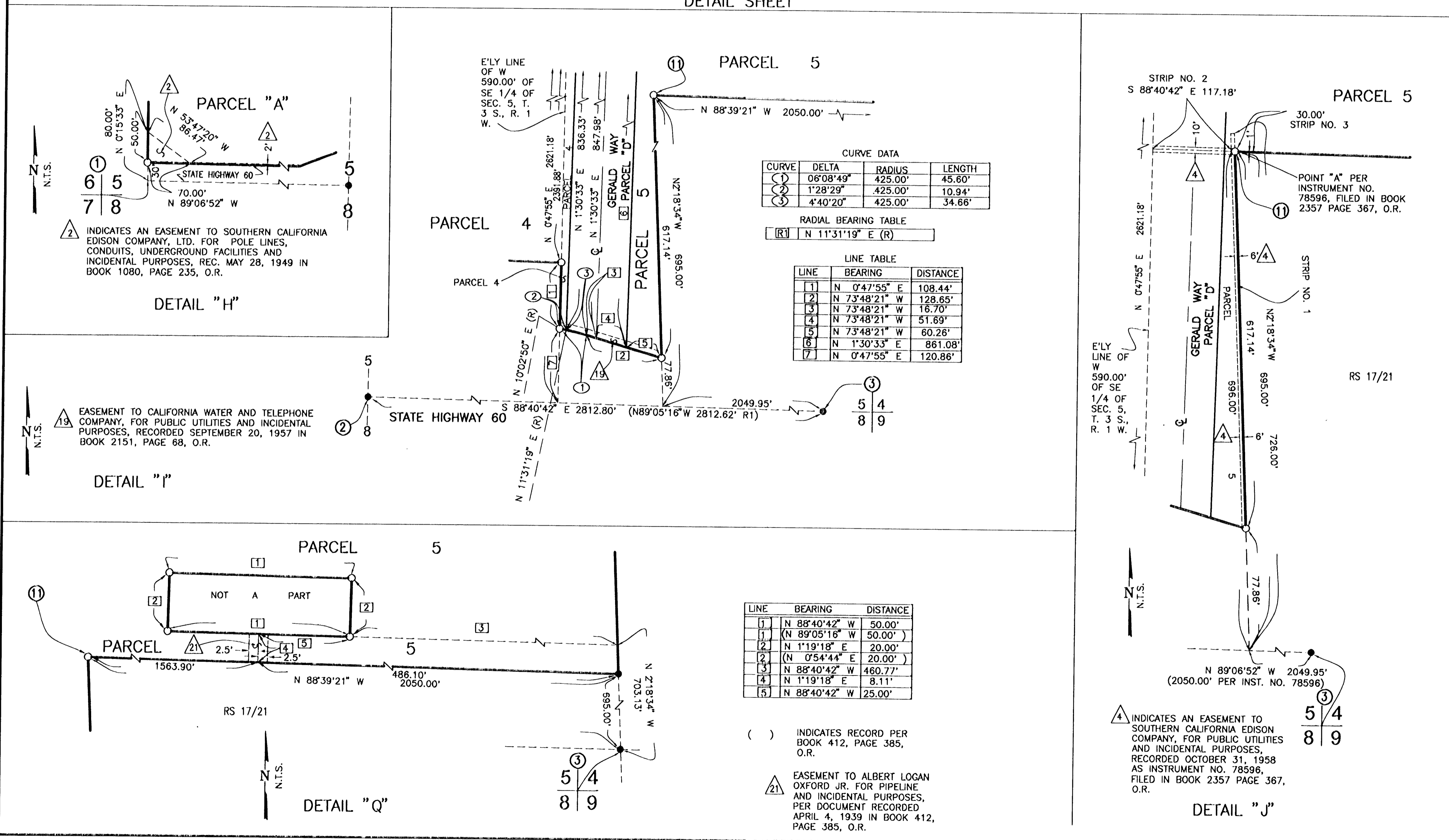

PARCEL 5

E'LY LINE OF W 590.00' OF SE 1/4 OF SEC. 5, T. 3 S., R. 1 W.

CURVE	DELTA	RADIUS	LENGTH
(1)	0°08'49"	425.00'	45.60'
(2)	1°28'29"	425.00'	10.94'
(3)	4°40'20"	425.00'	34.66'

LINE	BEARING	DISTANCE
(R)	N 11°31'19" E (R)	

LINE	BEARING	DISTANCE
(1)	N 0°47'55" E	108.44'
(2)	N 73°48'21" W	128.65'
(3)	N 73°48'21" W	16.70'
(4)	N 73°48'21" W	51.69'
(5)	N 73°48'21" W	60.26'
(6)	N 1°30'33" E	861.08'
(7)	N 0°47'55" E	120.86'

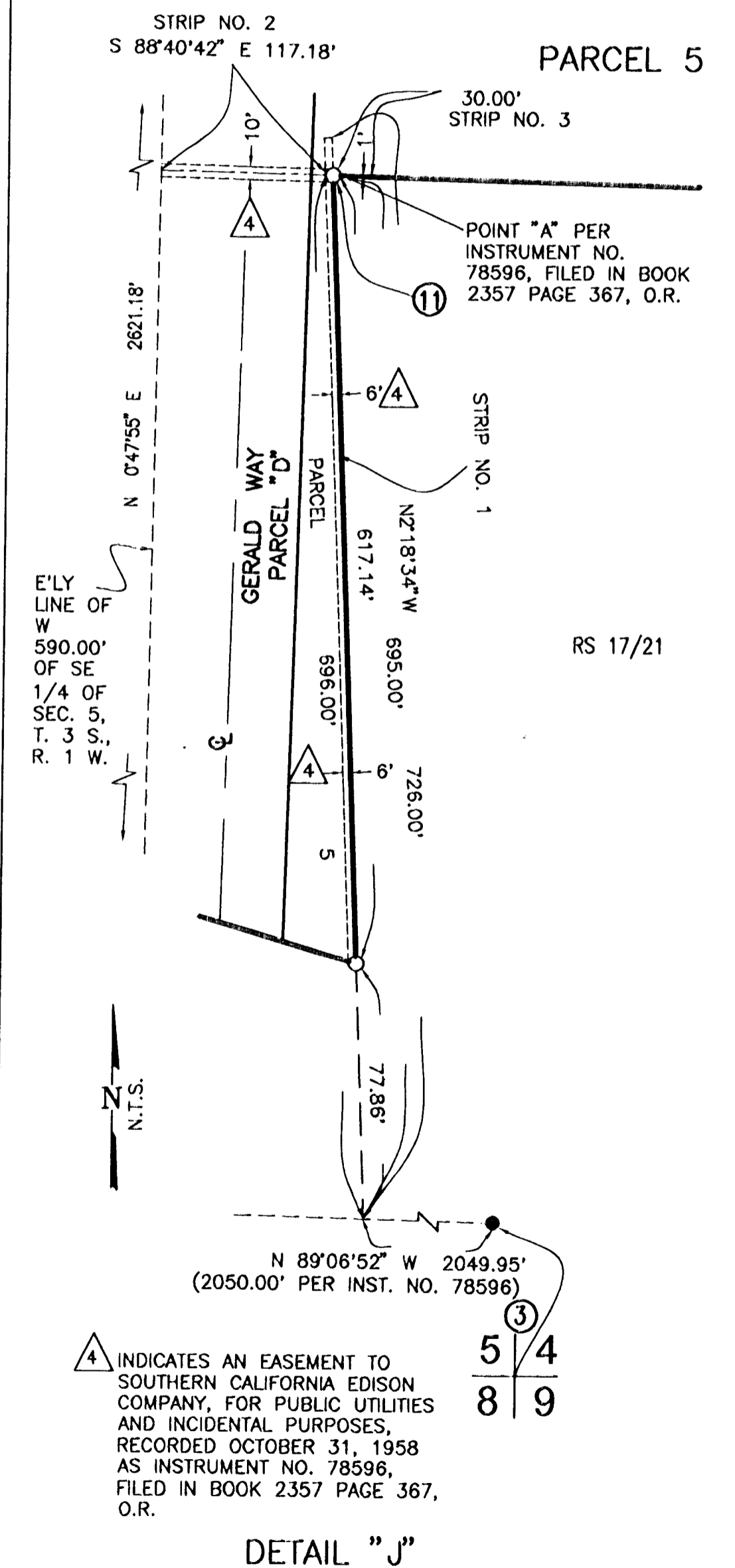

LINE	BEARING	DISTANCE
(1)	N 88°40'42" W	50.00'
(1)	(N 89°05'16" W 50.00')	
(2)	N 1°19'18" E	20.00'
(2)	(N 0°54'44" E 20.00')	
(3)	N 88°40'42" W	460.77'
(4)	N 1°19'18" E	8.11'
(5)	N 88°40'42" W	25.00'

( ) INDICATES RECORD PER BOOK 412, PAGE 385, O.R.

(A) EASEMENT TO ALBERT LOGAN OXFORD JR. FOR PIPELINE AND INCIDENTAL PURPOSES, PER DOCUMENT RECORDED, APRIL 4, 1939 IN BOOK 412, PAGE 385, O.R.

(A) INDICATES AN EASEMENT TO SOUTHERN CALIFORNIA EDISON COMPANY, FOR PUBLIC UTILITIES AND INCIDENTAL PURPOSES, RECORDED OCTOBER 31, 1958 AS INSTRUMENT NO. 78596, FILED IN BOOK 2357 PAGE 367, O.R.

NOTE:  
THIS MAP HAS BEEN RECORDED FOR FINANCING AND CONVEYANCE PURPOSES ONLY. NO USE IS PERMITTED WITHOUT ADDITIONAL CITY APPROVALS.

IN THE CITY OF BEAUMONT, COUNTY OF RIVERSIDE, STATE OF CALIFORNIA

# PARCEL MAP NO. 31368

BEING A SUBDIVISION OF A PORTION OF SECTION 5, TOWNSHIP 3 SOUTH, RANGE 1 WEST, SAN BERNARDINO BASE AND MERIDIAN, AS SHOWN BY UNITED STATES GOVERNMENT SURVEY.

THIELMANN ENGINEERS      JANUARY 2008

DETAIL SHEET

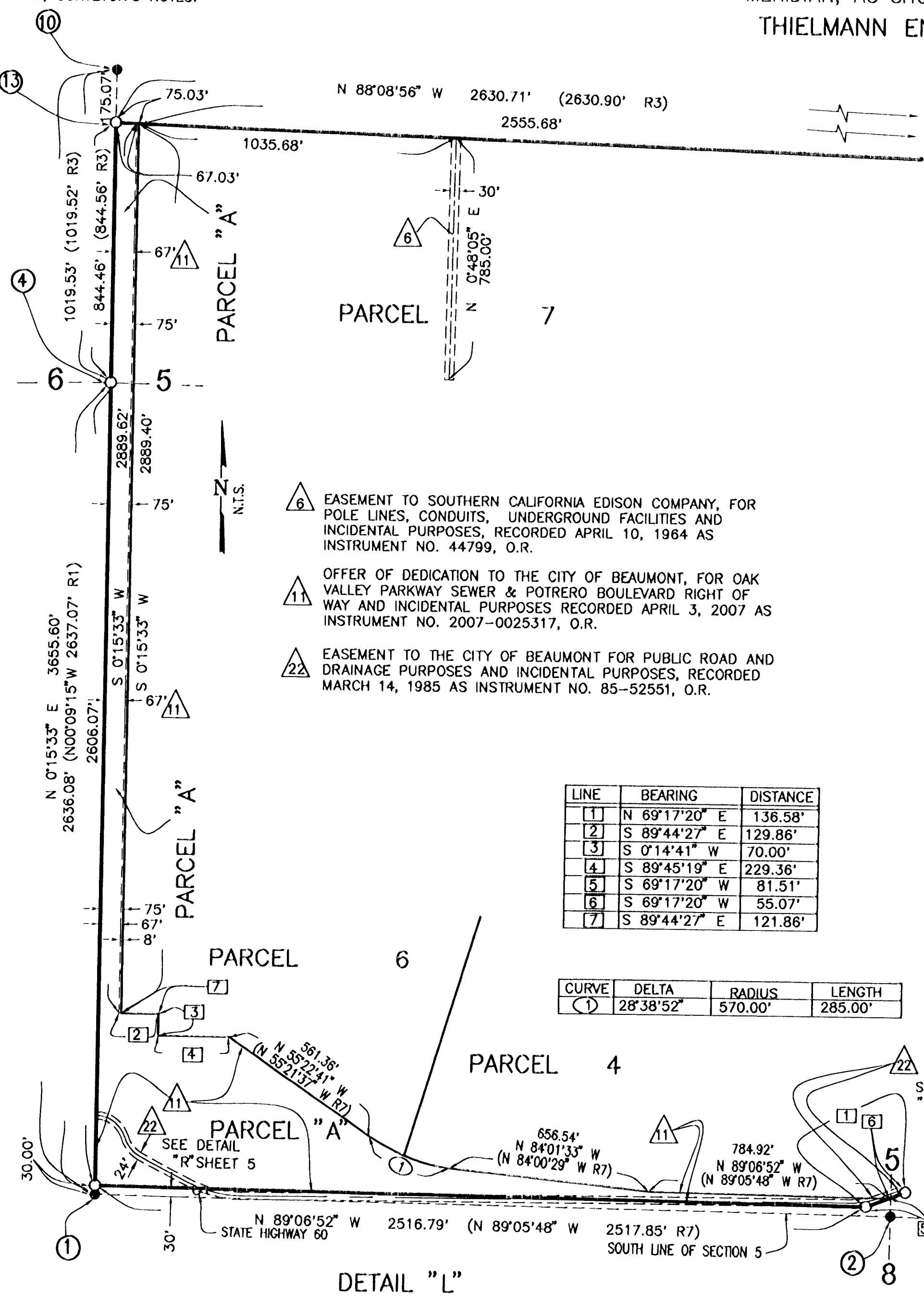

- △ EASEMENT TO SOUTHERN CALIFORNIA EDISON COMPANY, FOR POLE LINES, CONDUITS, UNDERGROUND FACILITIES AND INCIDENTAL PURPOSES, RECORDED APRIL 10, 1964 AS INSTRUMENT NO. 44799, O.R.
- △ OFFER OF DEDICATION TO THE CITY OF BEAUMONT, FOR OAK VALLEY PARKWAY SEWER & POTRERO BOULEVARD RIGHT OF WAY AND INCIDENTAL PURPOSES RECORDED APRIL 3, 2007 AS INSTRUMENT NO. 2007-0025317, O.R.
- △ EASEMENT TO THE CITY OF BEAUMONT FOR PUBLIC ROAD AND DRAINAGE PURPOSES AND INCIDENTAL PURPOSES, RECORDED MARCH 14, 1985 AS INSTRUMENT NO. 85-52551, O.R.

LINE	BEARING	DISTANCE
1	N 69°17'20" E	136.58'
2	S 89°44'27" E	129.86'
3	S 0°14'41" W	70.00'
4	S 89°45'19" E	229.36'
5	S 69°17'20" W	81.51'
6	S 69°17'20" W	55.07'
7	S 89°44'27" E	121.86'

CURVE	DELTA	RADIUS	LENGTH
(1)	28°38'52"	570.00'	285.00'

CURVE DATA			
CURVE	DELTA	RADIUS	LENGTH
(1)	06°08'49"	425.00'	45.60'

LINE	BEARING	DISTANCE
1	N 76°19'26" W	12.00'
2	N 76°19'26" W	10.00'
3	N 1°57'41" E	107.58'
4	N 88°18'21" W	116.62'
5	N 0°47'55" E	108.44'
6	N 9°55'34" E	41.00'
7	N 76°19'26" W	22.00'
8	N 64°22'39" E	30.00'
9	N 44°14'06" E	67.91'
10	N 82°50'26" W	15.00'
11	N 30°00'31" W	160.64'
12	N 0°47'55" E	120.86'

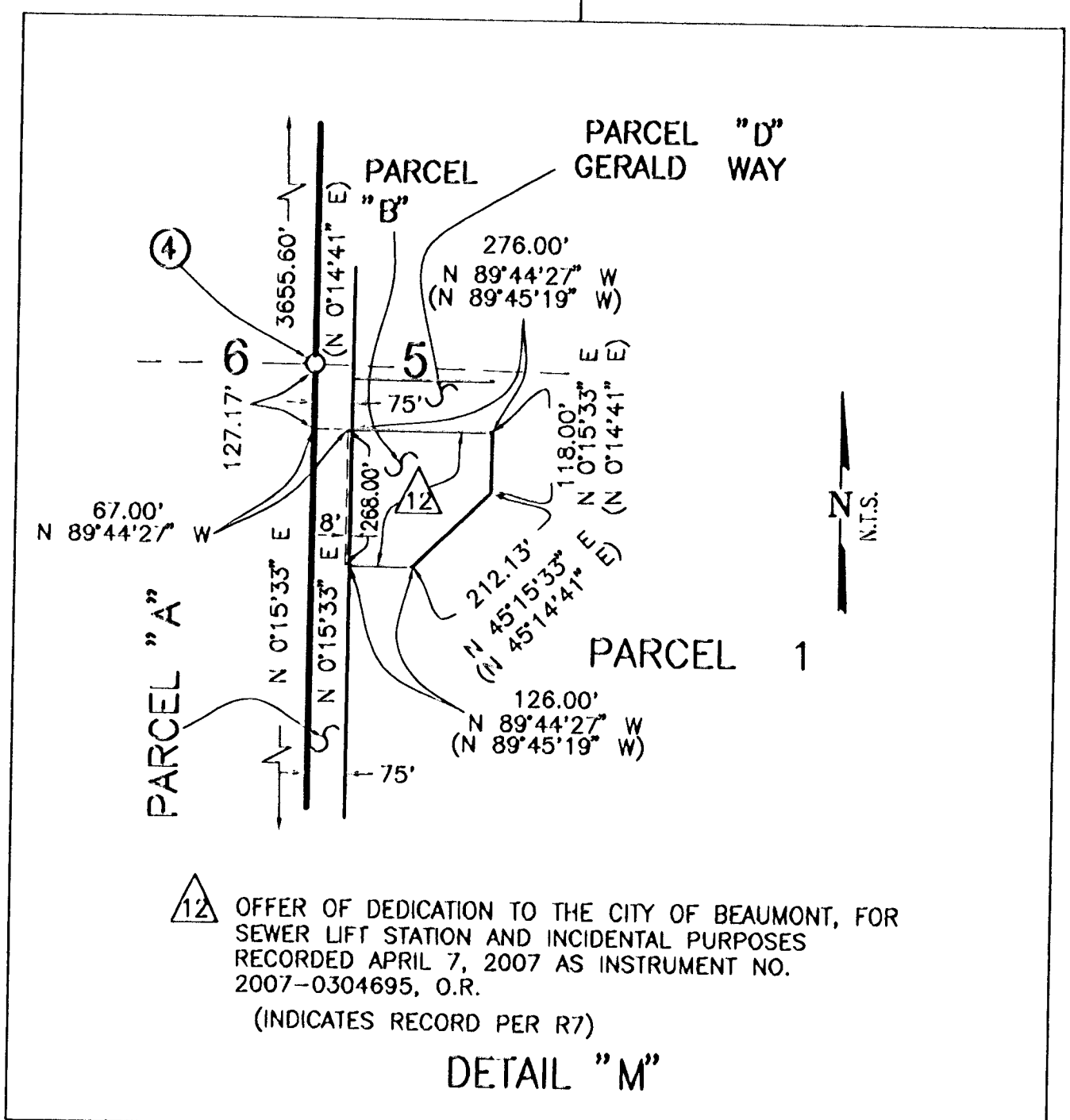
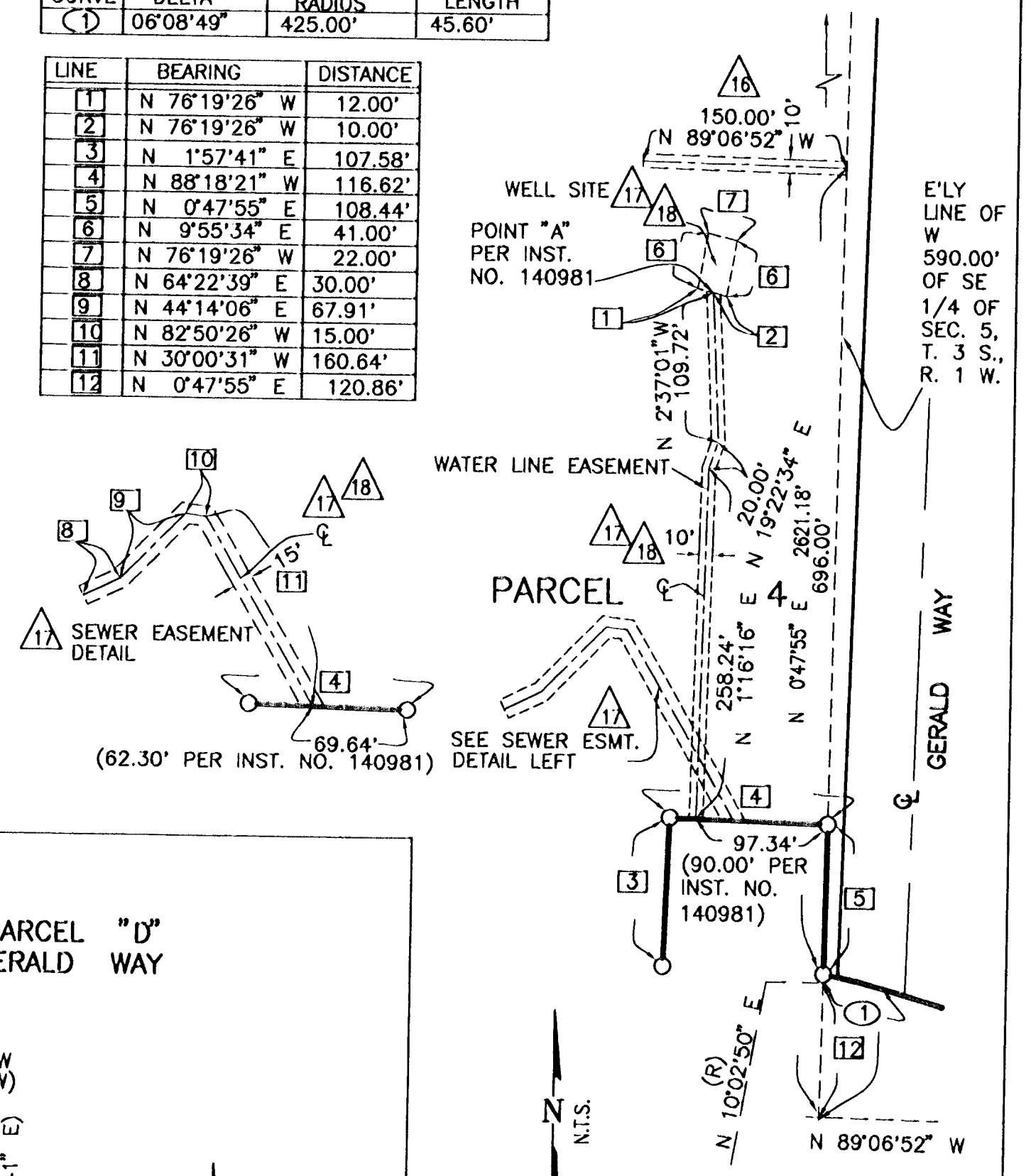

- △ EASEMENT TO SOUTHERN CALIFORNIA EDISON COMPANY, FOR EITHER OR BOTH POLE LINES, CONDUITS OR UNDERGROUND FACILITIES AND INCIDENTAL PURPOSES, RECORDED OCTOBER 31, 1958 IN BOOK 2357, PAGE 368, O.R.
- △ EASEMENT TO ELMER D. AND MOIRA M. SCHMIDT, FOR WATER LINES, WELL SITE, SEWER LINES AND INCIDENTAL PURPOSES, RECORDED JULY 25, 1977 AS INSTRUMENT NO. 140981, O.R.
- △ EASEMENT TO GERALD AND FRANCES KAUSHANSKY AND JOHN A. AND KAY R. RINALDI, FOR WATER LINES, WELL SITE, AND INCIDENTAL PURPOSES, RECORDED FEBRUARY 10, 1978 AS INSTRUMENT NO. 26524, O.R.

△ OFFER OF DEDICATION TO THE CITY OF BEAUMONT, FOR SEWER LIFT STATION AND INCIDENTAL PURPOSES RECORDED APRIL 7, 2007 AS INSTRUMENT NO. 2007-0304695, O.R.  
(INDICATES RECORD PER R7)

CITY 229  
53

IN THE CITY OF BEAUMONT, COUNTY OF RIVERSIDE, STATE OF CALIFORNIA

SHEET 8 OF 8 SHEETS

# PARCEL MAP NO. 31368

BEING A SUBDIVISION OF A PORTION OF SECTION 5, TOWNSHIP 3 SOUTH, RANGE 1 WEST, SAN BERNARDINO BASE AND MERIDIAN, AS SHOWN BY UNITED STATES GOVERNMENT SURVEY.

THIELMANN ENGINEERS JANUARY 2008

DETAIL SHEET

NOTE:  
THIS MAP HAS BEEN RECORDED FOR FINANCING AND CONVEYANCE PURPOSES ONLY. NO USE IS PERMITTED WITHOUT ADDITIONAL CITY APPROVALS.

SEE SHEET 3 FOR EASEMENT NOTES, FOUND MONUMENT DESCRIPTIONS, BASIS OF BEARINGS NOTE, SURVEYOR'S NOTES.

CURVE DATA

CURVE	DELTA	RADIUS	LENGTH
①	10°08'57"	100.00'	17.71'
②	24°10'33"	883.00'	372.58'
③	03°36'34"	883.00'	55.63'
④	20°33'59"	883.00'	316.95'
⑤	24°10'33"	817.00'	344.73'
⑥	24°10'33"	850.00'	358.66'
⑦	83°13'33"	1450.00'	2106.22'
⑧	2°36'30"	1450.00'	66.01'

CURVE	DELTA	RADIUS	LENGTH
①	D=22°19'53"	R=405.00'	L=157.85'
②	D=84°29'08"	R=395.00'	L=582.45'
③	D=68°52'35"	R=255.00'	L=306.54'
④	D=9°30'00"	R=295.00'	L=48.91'
⑤	D=25°15'00"	R=565.00'	L=248.99'
⑥	D=12°48'30"	R=565.00'	L=126.30'
⑦	D=34°42'28"	R=200.00'	L=121.15'
⑧	D=26°53'10"	R=245.00'	L=114.97'

LINE	BEARING	DISTANCE
1	N 69°17'20" E	136.58'
2	N 41°44'47" W	74.31'
3	N 68°56'06" E	53.67'
4	N 0°14'26" E	150.00'
5	N 62°23'41" E	67.53'
6	N 82°23'41" E	111.11'
7	N 88°06'19" W	350.17'
8	N 66°38'41" E	228.27'
9	N 43°31'37" W	139.87'
10	N 63°54'45" E	348.57'

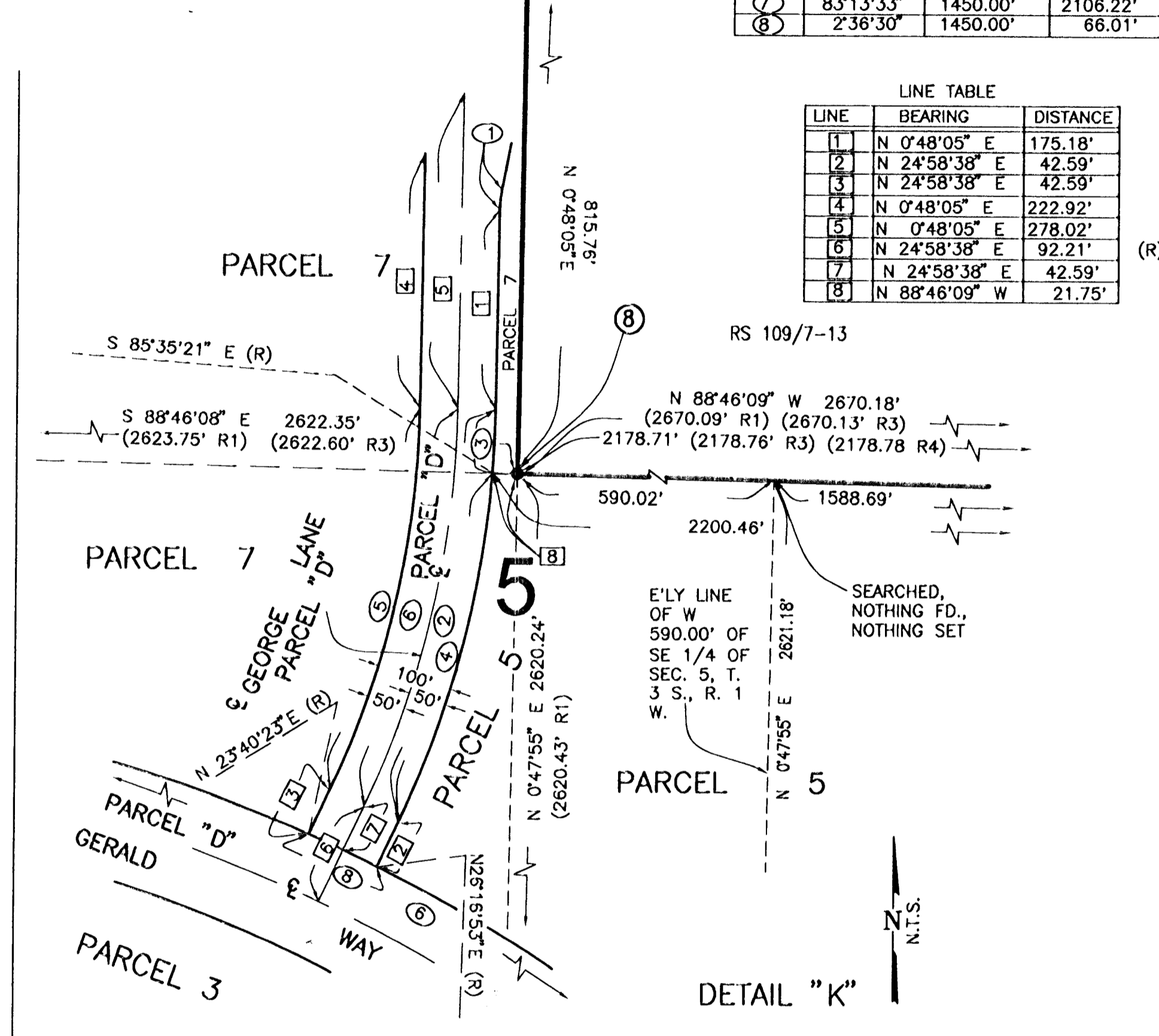
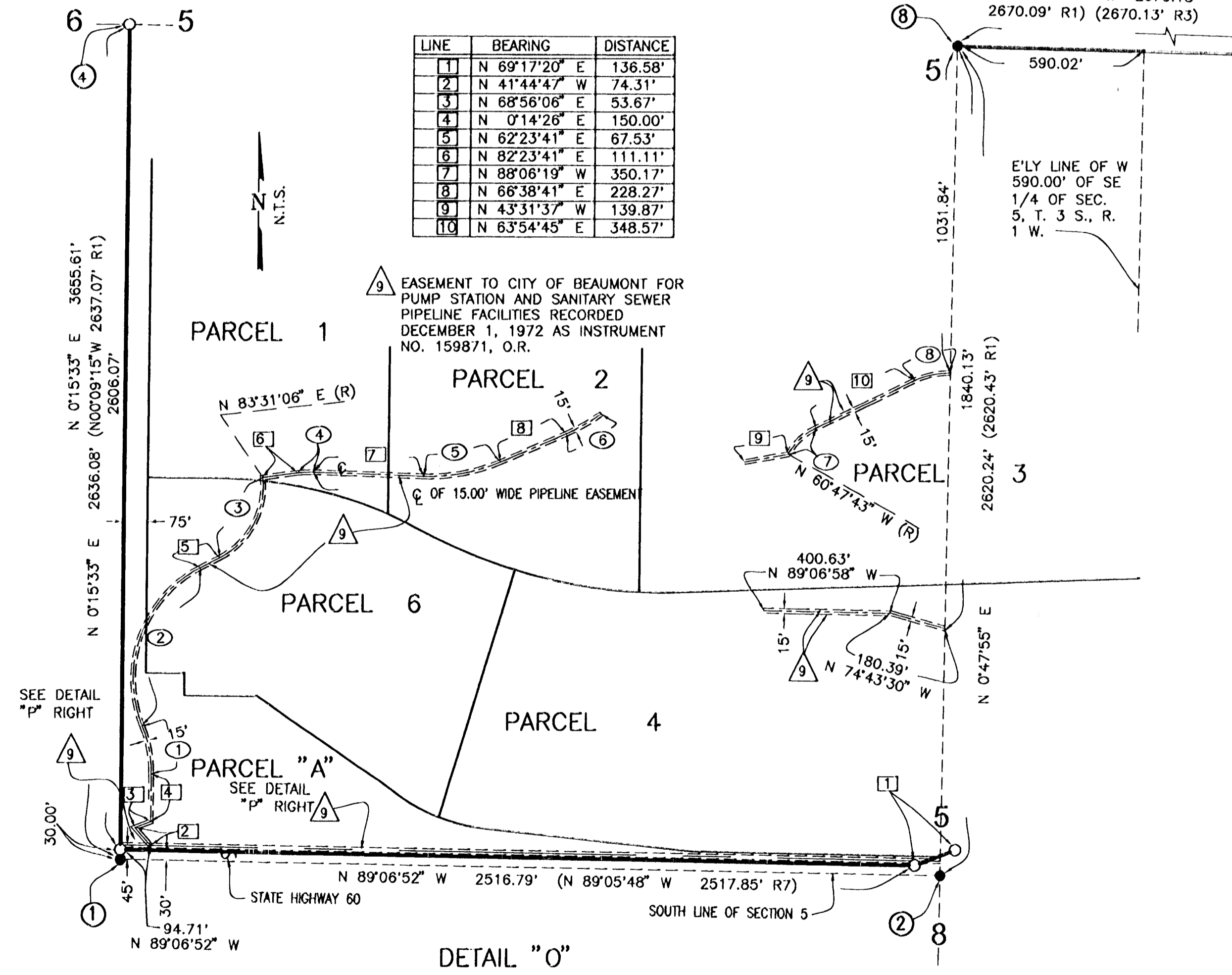

LINE TABLE

LINE	BEARING	DISTANCE
1	N 0°48'05" E	175.18'
2	N 24°58'38" E	42.59'
3	N 24°58'38" E	42.59'
4	N 0°48'05" E	222.92'
5	N 0°48'05" E	278.02'
6	N 24°58'38" E	92.21'
7	N 24°58'38" E	42.59'
8	N 88°46'09" W	21.75'

