

**CITY OF BEAUMONT
PUBLIC WORKS AGREEMENT**

This PUBLIC WORKS AGREEMENT (“Agreement”) is made and effective upon signature, by and between the City of Beaumont, a municipal corporation (“CITY”), and CT&T Concrete Paving inc., (“CONTRACTOR”), a California Corporation. In consideration of the mutual covenants and conditions set forth herein, the parties agree as follows:

FEDERAL FUNDING

This project is being financed with Community Development Block Grant funds from the U.S. Department of Housing and Urban Development (24 CFR Part 570) and subject to certain requirements including: compliance with Section 3 (24 CFR Part 75) Economic Opportunities requirements; payment of Federal Davis-Bacon prevailing wages; Federal Labor Standards Provisions (HUD 4010); Executive Order #11246; and others. Information pertaining to the Federal requirements is on file with the County of Riverside Department of Housing Homelessness Prevention and Workforce Solutions.

I. SCOPE OF WORK

The CONTRACTOR shall perform within the time set forth in Article 2 of this Agreement and shall furnish all labor, materials, equipment, tools, utility services, and transportation and perform and complete all work required in connection with the Citywide Sidewalk Improvement Project (hereinafter “Project”). CONTRACTOR’s Bid, dated April 03, 2024, is attached hereto as Exhibit A and incorporated herein by this reference. The Scope of Work for the Project is set forth in the Invitation. In the event that any terms of the Bid are different from the Invitation for Bids, the Invitation for Bids shall control. Any additional terms in the Bid that purport to bind the City to any additional terms not contained in this Agreement and related attachments shall not be binding on the City.

By entering into this Agreement, CONTRACTOR acknowledges that there may be other contractors on the site whose work will be coordinated with that of its own. CONTRACTOR expressly warrants and agrees that it will cooperate with other contractors and will do nothing to delay, hinder, or interfere with the work of other separate contractors, the CITY, the Construction Manager, the Engineer, or utilities. CONTRACTOR also expressly agrees that, in the event its work is hindered, delayed, interfered with, or otherwise affected by a separate contractor, its sole remedy will be a direct action against the separate contractor. To the extent allowed by law, the CONTRACTOR will have no remedy, and hereby expressly waives any remedy against the CITY, the Construction Manager (if any), and the Engineer on account of delay, hindrance, interference, or other events.

II. TIME FOR PROJECT COMPLETION

All of CONTRACTOR's work on the Project shall be completed within durations established for the individual activities. All work shall commence ten (10) calendar days after receiving a written Notice of Award from the CITY or Construction Manager, if a Construction Manager is employed by CITY on the Project. CONTRACTOR shall refer to the invitations for bids, and Project Plans and Specifications, all of which, as set forth below, are incorporated herein by reference, for contractual obligations regarding individual activity durations.

III. THE CONTRACT SUM

The CITY shall pay the CONTRACTOR for the performance of this Agreement, subject to any additions and deductions provided in the Project documents, the maximum sum of Four Hundred Twenty-Eight Thousand Three Hundred Fifty Five (\$428,355) Dollars.

IV. PROGRESS PAYMENTS

Based upon Applications for Payment submitted to the Engineer by the CONTRACTOR and Certificates for Payment issued by the Engineer, the CITY shall make progress payments on account of the Contract Sum to the CONTRACTOR as provided in the General Conditions, which are fully incorporated into this Agreement by this reference.

This Agreement is subject to the provisions of Article 1.7 (commencing at Section 20104.50) of Division 2, Part 3 of the Public Contract Code regarding prompt payment of contractors by local governments. Article 1.7 mandates certain procedures for the payment of undisputed and properly submitted payment requests within 30 days after receipt, for the review of payment requests, for notice to Contractor of improper payment requests, and provides for the payment of interest on progress payment requests which are not timely made in accordance with that Article. This Agreement hereby incorporates the provisions of Article 1.7 as though fully set forth herein.

V. INDEMNITY, DEFENSE AND HOLD HARMLESS AGREEMENT

CONTRACTOR shall indemnify, defend with legal counsel approved by CITY, and hold harmless CITY, its officers, officials, employees and volunteers from and against all liability, loss, damage, expense, cost (including without limitation reasonable legal counsel fees, expert fees and all other costs and fees of litigation) of every nature arising out of or in connection with CONTRACTOR's negligence, recklessness or willful misconduct in the performance of work hereunder or its failure to comply with any of its obligations contained in this Agreement, except such loss or damage which is caused by the sole or active negligence or willful misconduct of the CITY. Should conflict of interest principles

preclude a single legal counsel from representing both CITY and CONTRACTOR, or should CITY otherwise find CONTRACTOR's legal counsel unacceptable, then CONTRACTOR shall reimburse the CITY its costs of defense, including without limitation reasonable legal counsels fees, expert fees and all other costs and fees of litigation. The CONTRACTOR shall promptly pay any final judgment rendered against the CITY (and its officers, officials, employees and volunteers) with respect to claims determined by a trier of fact to have been the result of the CONTRACTOR's negligent, reckless or wrongful performance. It is expressly understood and agreed that the foregoing provisions are intended to be as broad and inclusive as is permitted by the law of the State of California and will survive termination of this Agreement.

CONTRACTOR obligations under this section apply regardless of whether or not such claim, charge, damage, demand, action, proceeding, loss, stop notice, cost, expense, judgment, civil fine or penalty, or liability was caused in part or contributed to by an Indemnitee. However, without affecting the rights of CITY under any provision of this agreement, CONTRACTOR shall not be required to indemnify and hold harmless CITY for liability attributable to the active negligence of CITY, provided such active negligence is determined by agreement between the parties or by the findings of a court of competent jurisdiction. In instances where CITY is shown to have been actively negligent and where CITY active negligence accounts for only a percentage of the liability involved, the obligation of CONTRACTOR will be for that entire portion or percentage of liability not attributable to the active negligence of CITY.

CONTRACTOR shall indemnify and hold harmless the County of Riverside, its Agencies, Districts, Special Districts and Departments, their respective directors, officers, Board of Supervisors, elected and appointed officials, employees, agents and representatives (individually and collectively hereinafter referred to as Indemnitees) from any liability whatsoever, based or asserted upon any services of CONTRACTOR, its officers, employees, subcontractors, agents or representatives arising out of or in any way relating to this Agreement, including but not limited to property damage, bodily injury, or death or any other element of any kind or nature whatsoever arising from the performance of CONTRACTOR, its officers, employees, subcontractors, agents or representatives Indemnitors from this Agreement. CONTRACTOR shall defend, at its sole expense, all costs and fees including, but not limited, to attorney fees, cost of investigation, defense and settlements or awards, the Indemnitees in any claim or action based upon such alleged acts or omissions.

VI. PREVAILING WAGES

- A. Contractor shall comply with all applicable laws and regulations relating to prevailing wages. Wage rates for this Project shall be in accordance with the "General Wage Determination Made By the Director of Industrial

Relations Pursuant To California Labor Code, Part 7, Chapter 1, Article 2, Sections 1770, 1773 and 1773.1", for Riverside County. Wage rates shall conform with those posted at Beaumont City Hall and the Project site.

- B. The following Labor Code sections are hereby referenced and made a part of this Agreement:
1. Section 1775 - Penalty for Failure to Comply with Prevailing Wage Rates.
 2. Section 1777.4 - Apprenticeship Requirements.
 3. Section 1777.5 - Apprenticeship Requirements.
 4. Section 1813 - Penalty for Failure to Pay Overtime.
 5. Sections 1810 and 1811 - Working Hour Restrictions.
 6. Section 1775 - Payroll Records.
 7. Section 1773.8 - Travel and Subsistence Pay.

PREVAILING WAGES

Pursuant to Section 1773 of the Labor Code, the general prevailing wage rates, including the per diem wages applicable to the work, and for holiday and overtime work, including employer payments for health and welfare, pension, vacation, and similar purposes, in the County of Riverside in which the work is to be done, have been determined by the Director of the Department of Industrial Relations, State of California. These wages are set forth in the General Prevailing Wage Rates for this project, available from the California Department of Industrial Relations' Internet web site at www.dir.ca.gov. Future effective prevailing wage rates which have been predetermined, and are on file with the California Department of Industrial Relations, are referenced but not printed in the general prevailing wage rates.

The Federal minimum wage rate requirements, as predetermined by the U.S. Secretary of Labor, are set forth in the books issued for bidding purposes, referred to herein as Project Bid Documents (Special Federal Provisions), and in copies of this book which may be examined at the office described above where the project plans, special provisions, and proposal forms may be seen. Addenda to modify the minimum wage rates, if necessary, will be issued to holders of the Project Bid Documents.

VII. RECORD AUDIT

In accordance with Government Code, Section 8546.7, records of both the CITY and the CONTRACTOR shall be subject to examination and audit by the Auditor General for a period of three (3) years after final payment.

VIII. FINAL PAYMENT

Final payment, constituting the entire unpaid balance of the Agreement Sum, shall be paid by the CITY to the CONTRACTOR no sooner than thirty-five (35) days after a Notice of Completion has been recorded, unless otherwise stipulated in the Notice of Completion, provided the work has then been completed, the Agreement fully performed, and a final Certificate for Payment has been issued by the Engineer.

IX. CONTRACTOR'S FAILURE TO PROCURE COMPLETION OF PROJECT

In the event CONTRACTOR fails to furnish tools, equipment, or labor in the necessary quantity or quality, or fails to prosecute the work or any part thereof contemplated by this Agreement in a diligent and workmanlike manner, and if the CONTRACTOR for a period of three (3) calendar days after receipt of written demand from CITY or its designated representative to do so, fails to furnish tools, equipment, or labor in the necessary quantity or quality, and to prosecute its work and all parts thereof in a diligent and workmanlike manner, or after commencing to do so within said three (3) calendar days, fails to continue to do so; then the CITY may exclude the CONTRACTOR from the premises, or any portion thereof, and take possession of said premises or any portion thereof, together with all material and equipment thereon, and may complete the work contemplated by this Agreement or any portion of said work, either by furnishing the tools, equipment, labor or material necessary, or by letting the unfinished portion of said work, or the portion taken over by the CITY to another contractor or by a combination of such methods. In any event, the procuring of the completion of said work, or the portion thereof taken over by the CITY, shall be a charge against the CONTRACTOR, and may be deducted from any money due or becoming due to CONTRACTOR from the CITY, or the CONTRACTOR shall pay the CITY the amount of said charge, or the portion thereof unsatisfied. The sureties, provided for under this Agreement shall become liable for payment should CONTRACTOR fail to pay in full any said cost incurred by the CITY.

X. INSURANCE

Prior to the beginning of and throughout the duration of the Project, CONTRACTOR and its subcontractors shall maintain insurance in conformance with the requirements set forth below. Attached hereto as Exhibit C are copies of Certificates of Insurance and the waiver of subrogation endorsement as required by Section 6.B.1. CONTRACTOR will use existing coverage to comply with these requirements. If that existing coverage does not meet the requirements set forth herein, CONTRACTOR agrees to amend, supplement or endorse the existing coverage to do so.

CONTRACTOR acknowledges that the insurance coverage and policy limits set forth in this section constitute the minimum amount of coverage required. Any insurance proceeds available to CONTRACTOR or its subcontractors in excess

of the limits and coverage identified in this Agreement and which is applicable to a given loss, claim or demand, will be equally available to CITY.

A. Types of Insurance

Without limiting CONTRACTOR's indemnification of CITY, and prior to commencement of Work, CONTRACTOR shall obtain, provide and maintain at its own expense during the term of this Agreement, policies of insurance of the type and amounts described below and in a form satisfactory to CITY:

1. **General liability insurance.** CONTRACTOR shall maintain commercial general liability insurance with coverage at least as broad as Insurance Services Office form CG 00 01, in an amount not less than \$1,000,000 per occurrence, \$2,000,000 general aggregate, for bodily injury, personal injury, and property damage, and a \$2,000,000 completed operations aggregate. The policy must include contractual liability that has not been amended. Any endorsement restricting standard ISO "insured contract" language will not be accepted.
2. **Automobile liability insurance.** CONTRACTOR shall maintain automobile insurance at least as broad as Insurance Services Office form CA 00 01 covering bodily injury and property damage for all activities of the CONTRACTOR arising out of or in connection with Work to be performed under this Agreement, including coverage for any owned, hired, non-owned or rented vehicles, in an amount not less than \$1,000,000 combined single limit for each accident.
3. **Umbrella or excess liability insurance.** If CONTRACTOR is using umbrella coverage to meet part of its liability insurance requirements under Paragraph 1 of this Section, CONTRACTOR shall obtain and maintain an umbrella or excess liability insurance that will provide bodily injury, personal injury, completed operations and property damage liability coverage at least as broad as the primary coverages set forth above, including commercial general liability and employer's liability. Such policy or policies shall include the following terms and conditions:
 - A drop down feature requiring the policy to respond in the event that any primary insurance that would otherwise have applied proves to be uncollectable in whole or in part for any reason;
 - Pay on behalf of wording as opposed to reimbursement;
 - Concurrency of effective dates with primary policies;
 - Policies shall "follow form" to the underlying primary policies; and
 - Insureds under primary policies shall also be insureds under the umbrella or excess policies.

4. **Workers' compensation insurance.** CONTRACTOR shall maintain Workers' Compensation Insurance (Statutory Limits) and Employer's Liability Insurance (with limits of at least \$1,000,000) for CONTRACTOR's employees in accordance with the laws of the State of California, Section 3700 of the Labor Code. In addition, CONTRACTOR shall require each subcontractor to similarly maintain Workers' Compensation Insurance and Employer's Liability Insurance in accordance with the laws of the State of California, Section 3700 for all of the subcontractor's employees.

CONTRACTOR shall submit to CITY, along with the certificate of insurance, a Waiver of Subrogation endorsement in favor of CITY, its officers, agents, employees and volunteers.

5. **Pollution liability insurance.** Environmental Impairment Liability Insurance shall be written on a CONTRACTOR's Pollution Liability form or other form acceptable to CITY providing coverage for liability arising out of sudden, accidental and gradual pollution and remediation. The policy limit shall be no less than \$1,000,000 dollars per claim and in the aggregate. All activities contemplated in this Agreement shall be specifically scheduled on the policy as "covered operations." The policy shall provide coverage for the hauling of waste from the project site to the final disposal location, including non-owned disposal sites.

Products/completed operations coverage shall extend a minimum of three (3) years after project completion. Coverage shall be included on behalf of the insured for covered claims arising out of the actions of independent contractors. If the insured is using subcontractors, the Policy must include work performed "by or on behalf" of the insured. Policy shall contain no language that would invalidate or remove the insurer's duty to defend or indemnify for claims or suits expressly excluded from coverage. Policy shall specifically provide for a duty to defend on the part of the insurer. The CITY, its officials, officers, agents, and employees, shall be included as insureds under the policy.

6. **Builder's risk insurance.** Upon commencement of construction and with approval of CITY, CONTRACTOR shall obtain and maintain builder's risk insurance for the entire duration of the Project until only the CITY has an insurable interest. The Builder's Risk coverage shall include the coverages as specified below.

The named insureds shall be CONTRACTOR and CITY, including its officers, officials, employees, and agents. All Subcontractors (excluding those solely responsible for design Work) of any tier and suppliers shall be included as additional insureds as their interests may

appear. CONTRACTOR shall not be required to maintain property insurance for any portion of the Project following transfer of control thereof to CITY. The policy shall contain a provision that all proceeds from the builder's risk policy shall be made payable to the CITY. The CITY will act as a fiduciary for all other interests in the Project.

Policy shall be provided for replacement value on an "all risk" basis for the completed value of the project. There shall be no coinsurance penalty or provisional limit provision in any such policy. Policy must include: (1) coverage for any ensuing loss from faulty workmanship, Nonconforming Work, omission or deficiency in design or specifications; (2) coverage against machinery accidents and operational testing; (3) coverage for removal of debris, and insuring the buildings, structures, machinery, equipment, materials, facilities, fixtures and all other properties constituting a part of the Project; (4) Ordinance or law coverage for contingent rebuilding, demolition, and increased costs of construction; (5) transit coverage (unless insured by the supplier or receiving contractor), with sub-limits sufficient to insure the full replacement value of any key equipment item; (6) Ocean marine cargo coverage insuring any Project materials or supplies, if applicable; (7) coverage with sub-limits sufficient to insure the full replacement value of any property or equipment stored either on or off the Site or any staging area. Such insurance shall be on a form acceptable to CITY to ensure adequacy of terms and sublimits and shall be submitted to the CITY prior to commencement of construction.

B. Other provisions or requirements

1. **Proof of insurance.** CONTRACTOR shall provide certificates of insurance to CITY as evidence of the insurance coverage required herein, along with a waiver of subrogation endorsement for workers' compensation. Insurance certificates and endorsements must be approved by CITY's risk manager prior to commencement of performance. Current certification of insurance shall be kept on file with CITY at all times during the term of this contract. CITY reserves the right to require complete, certified copies of all required insurance policies, at any time.
2. **Duration of coverage.** CONTRACTOR shall procure and maintain for the duration of the contract insurance against claims for injuries to persons or damages to property, which may arise from or in connection with the performance of the Work hereunder by CONTRACTOR, his agents, representatives, employees or subcontractors. CONTRACTOR must maintain general liability and umbrella or excess liability insurance for as long as there is a statutory exposure to completed operations claims. CITY and its officers,

officials, employees, and agents shall continue as additional insureds under such policies.

- 3. Primary/noncontributing.** Coverage provided by CONTRACTOR shall be primary and any insurance or self-insurance procured or maintained by CITY shall not be required to contribute with it. The limits of insurance required herein may be satisfied by a combination of primary and umbrella or excess insurance. Any umbrella or excess insurance shall contain or be endorsed to contain a provision that such coverage shall also apply on a primary and non-contributory basis for the benefit of CITY before the CITY's own insurance or self-insurance shall be called upon to protect it as a named insured.
- 4. CITY's rights of enforcement.** In the event any policy of insurance required under this Agreement does not comply with these requirements or is canceled and not replaced, CITY has the right but not the duty to obtain the insurance it deems necessary and any premium paid by CITY will be promptly reimbursed by CONTRACTOR or CITY will withhold amounts sufficient to pay premium from CONTRACTOR payments. In the alternative, CITY may cancel this Agreement.
- 5. Acceptable insurers.** All insurance policies shall be issued by an insurance company currently authorized by the Insurance Commissioner to transact business of insurance or is on the List of Approved Surplus Line Insurers in the State of California, with an assigned policyholders' Rating of A- (or higher) and Financial Size Category Class VII (or larger) in accordance with the latest edition of Best's Key Rating Guide, unless otherwise approved by the CITY's risk manager.
- 6. Waiver of subrogation.** All insurance coverage maintained or procured pursuant to this agreement shall be endorsed to waive subrogation against CITY, its elected or appointed officers, agents, officials, employees and volunteers or shall specifically allow CONTRACTOR or others providing insurance evidence in compliance with these specifications to waive their right of recovery prior to a loss. CONTRACTOR hereby waives its own right of recovery against CITY, and shall require similar written express waivers and insurance clauses from each of its subconsultants.
- 7. Enforcement of contract provisions (non estoppel).** CONTRACTOR acknowledges and agrees that any actual or alleged failure on the part of the CITY to inform CONTRACTOR of non-compliance with any requirement imposes no additional obligations on the CITY nor does it waive any rights hereunder.

- 8. Requirements not limiting.** Requirements of specific coverage features or limits contained in this Section are not intended as a limitation on coverage, limits or other requirements, or a waiver of any coverage normally provided by any insurance. Specific reference to a given coverage feature is for purposes of clarification only as it pertains to a given issue and is not intended by any party or insured to be all inclusive, or to the exclusion of other coverage, or a waiver of any type. If the CONTRACTOR maintains higher limits than the minimums shown above, the CITY requires and shall be entitled to coverage for the higher limits maintained by the CONTRACTOR. Any available insurance proceeds in excess of the specified minimum limits of insurance and coverage shall be available to the CITY.
- 9. Notice of cancellation.** CONTRACTOR agrees to oblige its insurance agent or broker and insurers to provide to CITY with a thirty (30) day notice of cancellation (except for nonpayment for which a ten (10) day notice is required) or nonrenewal of coverage for each required coverage.
- 10. Additional insured status.** General liability policies shall provide or be endorsed to provide that CITY and its officers, officials, employees, agents, and volunteers shall be additional insureds under such policies. This provision shall also apply to any excess/umbrella liability policies.
- 11. Prohibition of undisclosed coverage limitations.** None of the coverages required herein will be in compliance with these requirements if they include any limiting endorsement of any kind that has not been first submitted to CITY and approved of in writing.
- 12. Separation of insureds.** A severability of interests provision must apply for all additional insureds ensuring that CONTRACTOR's insurance shall apply separately to each insured against whom claim is made or suit is brought, except with respect to the insurer's limits of liability. The policy(ies) shall not contain any cross-liability exclusions.
- 13. Pass through clause.** CONTRACTOR agrees to ensure that its subconsultants, subcontractors, and any other party involved with the project who is brought onto or involved in the project by CONTRACTOR, provide the same minimum insurance coverage and endorsements required of CONTRACTOR. CONTRACTOR agrees to monitor and review all such coverage and assumes all responsibility for ensuring that such coverage is provided in conformity with the requirements of this section. CONTRACTOR agrees that upon

request, all agreements with consultants, subcontractors, and others engaged in the project will be submitted to CITY for review.

14. CITY's right to revise requirements. The CITY reserves the right at any time during the term of the contract to change the amounts and types of insurance required by giving the CONTRACTOR a ninety (90) day advance written notice of such change. If such change results in substantial additional cost to the CONTRACTOR, the CITY and CONTRACTOR may renegotiate CONTRACTOR's compensation.

15. Self-insured retentions. Any self-insured retentions must be declared to and approved by CITY. CITY reserves the right to require that self-insured retentions be eliminated, lowered, or replaced by a deductible. Self-insurance will not be considered to comply with these specifications unless approved by CITY.

16. Timely notice of claims. CONTRACTOR shall give CITY prompt and timely notice of claims made or suits instituted that arise out of or result from CONTRACTOR's performance under this Agreement, and that involve or may involve coverage under any of the required liability policies.

17. Additional insurance. CONTRACTOR shall also procure and maintain, at its own cost and expense, any additional kinds of insurance, which in its own judgment may be necessary for its proper protection and prosecution of the Work.

XI. CONTRACTOR'S LICENSE

CONTRACTOR must possess at the time of commencing work and throughout the Project duration, a Contractor's License, issued by the State of California, which is current and in good standing. CONTRACTOR shall ensure that any subcontractor working on the Project possesses at the time of commencing work and throughout the Project duration, a Contractor's License, issued by the State of California, which is current and in good standing.

XII. REGISTRATION REQUIREMENTS

A. Pursuant to Section 1771.1(a) of the Labor Code:

"A contractor or subcontractor shall not be qualified to bid on, be listed in a bid proposal, subject to the requirements of Section 4104 of the Public Contract Code, or engage in the performance of any contract for public work, as defined in this chapter, unless currently registered and qualified to perform public work pursuant to Section 1725.5. It is not a violation of this section for an unregistered

contractor to submit a bid that is authorized by Section 7029.1 of the Business and Professions Code or by Section 10164 or 20103.5 of the Public Contract Code, provided the contractor is registered to perform public work pursuant to Section 1725.5 at the time the contract is awarded.”

B. CONTRACTOR must be registered with the Department of Industrial Relations (DIR) of the State of California in order to be eligible to work on public works projects. CONTRACTOR must ensure registration with the DIR that is active and in good standing.

C. No contractor or subcontractor may be listed on a bid proposal for a public works project (submitted on or after March 1, 2015) unless registered with the Department of Industrial Relations pursuant to Labor Code section 1725.5 [with limited exceptions from this requirement for bid purposes only under Labor Code section 1771.1(a)].

No contractor or subcontractor may be awarded a contract for public work on a public works project (awarded on or after April 1, 2015) unless registered with the Department of Industrial Relations pursuant to Labor Code section 1725.5.

This project is subject to compliance monitoring and enforcement by the Department of Industrial Relations.

D. The CONTRACTOR is not subject to public works requirements (including registration with the DIR) if the public works project is under \$1,000, unless the CITY knows that the same CONTRACTOR will be awarded total project costs in excess of \$1,000 for a given year.

XIII. CORPORATION IN GOOD STANDING

If CONTRACTOR is a corporation, the undersigned hereby represents and warrants that the corporation is duly incorporated and in good standing in the State of California, and that David Van Dyke whose title is President is authorized to act for and bind the corporation.

XIV. PROVISIONS REQUIRED BY LAW

Each and every provision of law and clause required by law to be inserted in this Agreement shall be deemed to be inserted herein and the Agreement shall be read and enforced as though it were included herein, and if through mistake or otherwise any such provision is not inserted, or is not currently inserted, then upon application of either party the Agreement shall forthwith be physically amended to make such insertion or correction.

XV. SUBSURFACE HAZARDOUS MATERIALS

- A. In the event trenches or other excavations extend deeper than four (4) feet below the surface, the CONTRACTOR shall promptly, and before the following conditions are disturbed, notify the CITY in writing of any:
1. Material that the CONTRACTOR believes may be material that is hazardous waste, as defined in Section 25117 of the Health and Safety Code that is required to be removed to a Class I, Class II or Class III disposal site in accordance with the provisions of existing law.
 2. Subsurface or latent physical conditions at the site differing from those indicated.
 3. Unknown physical conditions at the site of any unusual nature, different materially from those ordinarily encountered and generally recognized as inherent in the Work or the character provided for in the CONTRACT.
- B. Upon receipt of said notification the CITY will investigate the conditions, and if it finds that the conditions do materially so differ, or do involve hazardous waste, and cause a decrease or increase in the CONTRACTOR's cost of or the time required for performance of any part of the work, the CITY will issue a change order under the procedures described in the General Conditions.
- C. In the event that a dispute arises between the CITY and the CONTRACTOR whether the conditions materially differ, or involve hazardous waste or cause a decrease or increase in the CONTRACTOR's cost of or time required for performance of any part of the work, the CONTRACTOR shall not be excused from any scheduled completion date provided for by the Agreement, but shall proceed with all work to be performed under the Agreement. The CONTRACTOR shall retain any and all rights provided either by Agreement or by law which pertain to the resolution of disputes and protests between the contracting parties.

XVI. COMPONENT PARTS OF THE CONTRACT

This Agreement entered into consists of the following CONTRACT DOCUMENTS, all of which are component parts of the Agreement as if herein set out in full or attached hereto:

- | | |
|---|---------------------------------|
| X Notice Inviting Bids | X Labor and Materials Payment |
| X Scope of Work Summary | Bond |
| X Information for Bidders | X General and Supplemental |
| X Bid Form | Conditions |
| X Non-Collusion Affidavit | X Special Conditions |
| <input type="checkbox"/> Site Visit Certification | X Project Construction Schedule |
| X Faithful Performance Bond | X Proposed Subcontractors |

X Bid Bond	X Addenda
X Information Required of Bidder	X Drawings
X Construction Services Agreement	X Change Orders
X Certificate Regarding Worker's Compensation	X Shop Drawing Transmittals
X Drug-free Workplace Certification	X Contractor's Certificate Regarding Non-Asbestos Containing Materials
X Plans and Specifications	

All of the above-named CONTRACT DOCUMENTS are intended to be complementary. Work required by one of the above-named CONTRACT DOCUMENTS and not by others shall be done as if required by all.

Special Federal Requirements

1. Contractor and Owner do hereby acknowledge that this project will be partially or fully funded with Community Development Block Grant (CDBG) funds [24 CFR 570] and is therefore subject to applicable Federal procurement, labor, environmental, equal opportunity, and other regulations.

2. Contractor shall maintain and keep books and records on a current basis, recording all transactions pertaining to this agreement in a form in accordance with generally acceptable accounting principles. Said books and records shall be made available to the County, the State of California, the Federal government, and to any authorized representative thereof for the purposes of audit at all reasonable times and places. All such books and records shall be retained for such periods of time as required by law, provided, however, notwithstanding any shorter periods of

retention, all books, records, and supporting detail shall be retained for a period of at least four (4) years after the expiration of the term of this Agreement.

3. Contractor shall comply with the Davis-Bacon Fair Labor Standards Act (40 U.S.C.A. Section 3141-3148) and the implementation regulations thereof. Contractor shall comply with the U.S. Department of Housing and Urban Development's Federal Labor Standards Provisions (HUD 4010). Contractor acknowledges that the applicable Wage Determination for this project is:

General Decision Number: CA20240025

Modification Number: 4

Date: 03/08/2024

4. Section 3 Compliance: The Contractor hereby acknowledges that this federally-funded project is subject to Section 3 of the Housing and Urban Development Act of 1968 [12 U.S.C. 1701u and 24 CFR Part 75] and agrees to the following:

A. The work to be performed under this contract is subject to the requirements of Section 3 of the Housing and Urban Development Act of 1968, as amended, 12 U.S.C. 1701u (Section 3). The purpose of Section 3 is to ensure that employment and other economic opportunities generated by HUD assistance or HUD-assisted projects covered by Section 3, shall, to the greatest extent feasible, be directed to low- and very low-income persons, particularly persons who are recipients of HUD assistance for housing.

B. The parties to this contract agree to comply with HUD's regulations in 24 CFR Part 75, which implement Section 3. As evidenced by their execution of this contract, the parties to this contract certify that they are under no contractual or other impediment that would prevent them from complying with the Part 75 regulations.

C. The contractor agrees to send to each labor organization or representative of workers with which the contractor has a collective bargaining agreement or other understanding, if any, a notice advising the labor organization or workers' representative of the contractor's commitments under this Section 3 clause, and will post copies of the notice in conspicuous places at the work site where both employees and applicants for training and employment positions can see the notice. The notice shall describe the Section 3 preference, shall set forth minimum number and job titles subject to hire, availability of apprenticeship and training positions, the qualifications for each; and the name and location of the person(s) taking applications for each of the positions; and the anticipated date the work shall begin.

D. The contractor agrees to include this Section 3 clause in every subcontract subject to compliance with regulations in 24 CFR Part 75, and agrees to take appropriate action, as provided in an applicable provision of the subcontract or in this Section 3 clause, upon a finding that the subcontractor is in violation of the regulations in 24 CFR Part 75. The contractor will not subcontract with any subcontractor where the contractor has notice or knowledge that the subcontractor has been found in violation of the regulations in 24 CFR Part 75.

E. The contractor will certify that any vacant employment positions, including

training positions, that are filled (1) after the contractor is selected but before the contract is executed, and (2) with persons other than those to whom the regulations of 24 CFR Part 75 require employment opportunities to be directed, were not filled to circumvent the contractor's obligations under 24 CFR Part 75.

F. Noncompliance with HUD's regulations in 24 CFR Part 75 may result in sanctions, termination of this contract for default, and debarment or suspension from future HUD assisted contracts.

G. With respect to work performed in connection with Section 3 covered Indian housing assistance, Section 7(b) of the Indian Self-Determination and Education Assistance Act (25 U.S.C. 450e) also applies to the work to be performed under this contract. Section 7(b) requires that to the greatest extent feasible (i) preference and opportunities for training and employment shall be given to Indians, and (ii) preference in the award of contracts and subcontracts shall be given to Indian organizations and Indian-owned Economic Enterprises. Parties to this contract that are subject to the provisions of Section 3 and Section 7(b) agree to comply with Section 3 to the maximum extent feasible, but not in derogation of compliance with Section 7(b).

Additional Federal Requirements

Whereas, the work under this Agreement is subject to applicable Federal, State, and local laws and regulations, including but not limited to the regulations pertaining to the Community Development Block Grant program (24 CFR Part 570) and the Uniform Administrative Requirement, Cost Principles, and Audit Requirements for Federal Awards (2 CFR Part 200). Contractor, sub-contractors, Consultants, and sub-consultants agree to comply with, and are subject to, all applicable requirements as follows:

1. Equal Employment Opportunity - Compliance with Executive Order 11246 of September 24, 1965, entitled "Equal Employment Opportunity", as amended by Executive Order 11375 of October 13, 1967, and as supplemented in Department of Labor regulations (41 CFR Part 60). The Contractor/Consultant will not discriminate against any employee or applicant for employment because of race, color, religion, sex, sexual orientation, general identity or national origin. Contractor/Consultant will ensure that all qualified applicants will receive consideration for employment without regard to race, color, religion, sex sexual orientation, general identity or national origin. The Contractor/Consultant will take affirmative action to ensure that applicants are employed and the employees are treated during employment, without regard to their race color, religion, sex, sexual orientation, general identity or national origin. Such actions shall include, but are not limited to, the following: employment, up-grading, demotion, or transfer; recruitment or recruitment advertising; rates of pay or other forms of compensation; and selection for training, including apprenticeship. The Contractor/Consultant agrees to post in a conspicuous place, available to employees and applicants for employment, notices to be provided by the County setting forth the provisions of this non-discriminating clause.

2. Copeland "Anti-Kickback" Act (18 U.S.C. 874 and 40 U.S.C.A. Section 3145): All contracts and subgrants in excess of \$2,000 for construction or repair awarded by recipients and subrecipients shall include a provision for compliance with the Copeland "Anti-Kickback" Act (18 U.S.C. 874), as supplemented by Department of Labor regulations (29 CFR Part 3, "Contractors and Subcontractors on Public Building or Public Work Financed in Whole or in Part by Loans or Grants from the United States"). The Act provides that each contractor or subrecipient shall be prohibited from inducing, by any means, any person employed

in the construction, completion, or repair of public work, to give up any part of the compensation to which he is otherwise entitled. The recipient shall report all suspected or reported violations to HUD.

3. Davis-Bacon Act, as amended (40 U.S.C.A. Section 3141-3148): When required by Federal program legislation, all construction contracts awarded by the recipients and subrecipients of more than \$2000 shall include a provision for compliance with the Davis-Bacon Act (40 U.S.C. A. Section 3141-3148) and as supplemented by Department of Labor regulations (29 CFR Part 5, "Labor Standards Provisions Applicable to Contracts Governing Federally Financed and Assisted Construction"). Under the Davis Bacon Act, contractors shall be required to pay wages to laborers and mechanics at a rate not less than the minimum wages specified in a wage determination made by the U.S. Secretary of Labor. In addition, contractors shall be required to pay wages not less than once a week. The recipient shall place a copy of the current prevailing wage determination issued by the U.S. Department of Labor in each solicitation and the award of a contract shall be conditioned upon the acceptance of the wage determination. The recipient shall report all suspected or reported violations to HUD.

4. Contract Work Hours and Safety Standards Act (40 U.S.C.A. 32701 through 3708): Where applicable, all contracts awarded by recipients in excess of \$2,000 for construction contracts and in excess of \$2,500 for other contracts that involve the employment of mechanics or laborers shall include a provision for compliance with the Contract Work Hours and Safety Standards (40 U.S.C.A. 32701–3708), as supplemented by Department of Labor Regulations (29 CFR Part 5). Under Section 40 U.S.C.A. 3702, each contractor shall be required to compute the wages of every mechanic and laborer on the basis of a standard workweek of 40 hours. Work in excess of the standard workweek is permissible provided that the worker is compensated at a rate of not less than 1 1/2 times the basic rate of pay for all hours worked in excess of 40 hours in the workweek. 40 U.S.C.A. 3704 of the Act is applicable to construction work and provides that no laborer or mechanic shall be required to work in surroundings or under working conditions which are unsanitary, hazardous or dangerous. These requirements do not apply to the purchases of supplies or materials or articles ordinarily available on the open market, or contracts for transportation or transmission of intelligence.

5. Rights to Inventions Made Under a Contract or Agreement— Contracts or agreements for the performance of experimental, developmental, or research work shall provide for the rights of the Federal Government and the recipient in any resulting invention in accordance with 37 CFR part 401, "Rights to Inventions Made by Nonprofit Organizations and Small Business Firms Under Government Grants, Contracts and Cooperative Agreements," and any implementing regulations issued by HUD.

6. Rights to Data and Copyrights – Contractors and consultants agree to comply with all applicable provisions pertaining to the use of data and copyrights pursuant to 48 CFR Part 27.404-3, Federal Acquisition Regulations (FAR).

7. Air Pollution Prevention and Control (formally known as the Clean Air Act) (42 U.S.C.A. 7401 et seq.) and the Federal Water Pollution Control Act (33 U.S.C.A. Section 1251 et seq.), as amended:—Contracts and subgrants of amounts in excess of \$100,000 shall contain a provision that requires the recipient to agree to comply with all applicable standards, orders or regulations issued pursuant to the Clean Air Act (42 U.S.C. 7401 et seq.) and the Federal Water Pollution Control Act as amended (33 U.S.C.A. 1251 et seq.). Violations shall be reported to HUD and the Regional Office of the Environmental Protection Agency (EPA).

8. Byrd Anti-Lobbying Amendment (31 U.S.C.A. 1352)— Contractors who apply or bid for an award of \$100,000 or more shall file the required certification. Each tier certifies to the tier above that it will not and has not used Federal appropriated funds to pay any person or organization for influencing or attempting to influence an officer or employee of any agency, a member of Congress, officer or employee of Congress, or an employee of a member of Congress in connection with obtaining any Federal contract, grant or any other award covered by 31 U.S.C. 1352. Each tier shall also disclose any lobbying with non-Federal funds that takes place in connection with obtaining any Federal award. Such disclosures are forwarded from tier to tier up to the recipient.

9. Debarment and Suspension (Executive Orders (E.O. s) 12549 and 12689)—No contract shall be made to parties listed on the General Services Administration's List of Parties Excluded from Federal Procurement or Nonprocurement Programs in accordance with E.O.s 12549 and 12689, "Debarment and Suspension," as set forth at 24 CFR part 2424. This list contains the names of parties debarred, suspended,

or otherwise excluded by agencies, and contractors declared ineligible under statutory or regulatory authority other than E.O. 12549. Contractors with awards that exceed the small purchase threshold shall provide the required certification regarding its exclusion status and that of its principal employees.

10. Drug-Free Workplace Requirements— The Anti-Drug Abuse Act of 1988 (41 U.S.C.A. Section 8101-8103) requires grantees (including individuals) of federal agencies, as a prior condition of being awarded a grant, to certify that they will provide drug-free workplaces. Each potential recipient must certify that it will comply with drug-free workplace requirements in accordance with the Act and with HUD's rules at 24 CFR part 2425.

11. Access to Records and Records Retention: The Consultant or Contractor, and any sub-consultants or sub-contractors, shall allow all duly authorized Federal, State, and/or County officials or authorized representatives access to the work area, as well as all books, documents, materials, papers, and records of the Consultant or Contractor, and any sub-consultants or sub-contractors, that are directly pertinent to a specific program for the purpose of making audits, examinations, excerpts, and transcriptions. The Consultant or Contractor, and any sub-consultants or sub-contractors, further agree to maintain and keep such books, documents, materials, papers, and records, on a current basis, recording all transactions pertaining to this agreement in a form in accordance with generally acceptable accounting principles. All such books and records shall be retained for such periods of time as required by law, provided, however, notwithstanding

any shorter periods of retention, all books, records, and supporting detail shall be retained for a period of at least four (4) years after the expiration of the term of this Agreement.

12. Federal Employee Benefit Clause: No member of or delegate to the congress of the United States, and no Resident Commissioner shall be admitted to any share or part of this agreement or to any benefit to arise from the same.

13. Energy Efficiency: Mandatory standards and policies relating to energy efficiency which are contained in the State energy conservation plan issued in compliance with the Energy Policy and Conservation Act (Pub. L. 94A 163, Dec. 22, 1975; 42 U.S.C.A. Section 6201, et. seq., 89 Stat. 871).

14. Procurement of Recovered Materials (2 CFR 200.322.) A non-Federal entity that is a state agency or agency of a political subdivision of a state and its contractors must comply with 42 U.S.C. Section 6962 of the Solid Waste Disposal Act (42 U.S.C.A. Section 6901, et seq.), as amended by the Resource Conservation and Recovery Act. The requirements of Section 6002 include procuring only items designated in guidelines of the Environmental Protection Agency (EPA) at 40 CFR part 247 that contain the highest percentage of recovered materials practicable, consistent with maintaining a satisfactory level of competition, where the purchase price of the item exceeds \$10,000 or the value of the quantity acquired by the preceding fiscal year exceeded \$10,000; procuring solid waste management services in a manner that maximizes energy and resource recovery; and establishing an affirmative procurement program for procurement of recovered materials identified in the EPA guidelines.

15. Build America, Buy America (BABA) Act: The Grantee must comply with the requirements of the Build America, Buy America (BABA) Act, 41 USC 8301 note, and all applicable rules and notices, as may be amended, if applicable to the Grantee's infrastructure project. Pursuant to HUD's Notice, "Public Interest Phased Implementation Waiver for FY 2022 and 2023 of Build America, Buy America Provisions as Applied to Recipients of HUD Federal Financial Assistance" (88 FR 17001), any funds obligated by HUD on or after the applicable listed effective dates, are subject to BABA requirements, unless excepted by a waiver.

XVII. ENTIRE CONTRACT

This Agreement constitutes the entire contract of the parties. No other agreements or contracts, whether oral or written, pertaining to the work to be performed, exists between the parties. This Agreement can be modified only by an amendment in writing, signed by both parties.

[Signatures on following page.]

SIGNATURE PAGE TO

**CITY OF BEAUMONT
PUBLIC WORKS AGREEMENT**

CITY:

CITY OF BEAUMONT

By:

CONTRACTOR:

CT&T CONCRETE PAVING, INC.

By:

Print Name:

Jose Carvajal

Title:

President

**SIGNATURE PAGE TO
CITY OF BEAUMONT
PUBLIC WORKS AGREEMENT**

CITY:

CITY OF BEAUMONT

By:

David Fenn, Mayor

Date: _____

CONTRACTOR:

CT&T CONCRETE PAVING, INC.

By:

Print Name: Jose Caravajal

Title: President

Date: _____

ATTEST:

By:

Nicole Wheelright, Deputy City Clerk

APPROVED AS TO FORM:

By: _____
John O. Pinkney, City Attorney

CALIFORNIA ALL-PURPOSE CERTIFICATE OF ACKNOWLEDGMENT

A notary public or other officer completing this certificate verifies only the identity of the individual who signed the document to which this certificate is attached, and not the truthfulness, accuracy, or validity of that document.

State of California }

County of Los Angeles }

On April 18th, 2024 before me, Daniel A. Butler, A Notary Public,
(Here insert name and title of the officer)

personally appeared Jose Carvajal,
who proved to me on the basis of satisfactory evidence to be the person(s) whose name(s) ~~is~~ are subscribed to the within instrument and acknowledged to me that ~~he~~ she/they executed the same in ~~his~~ her/their authorized capacity(ies), and that by ~~his~~ her/their signature(s) on the instrument the person(s), or the entity upon behalf of which the person(s) acted, executed the instrument.

I certify under PENALTY OF PERJURY under the laws of the State of California that the foregoing paragraph is true and correct.

WITNESS my hand and official seal.

Daniel A. Butler
Notary Public Signature

(Notary Public Seal)

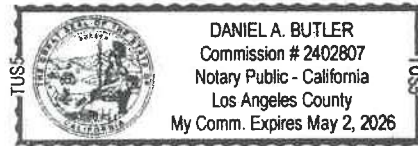

ADDITIONAL OPTIONAL INFORMATION

DESCRIPTION OF THE ATTACHED DOCUMENT

(Title or description of attached document)

(Title or description of attached document continued)

Number of Pages _____ Document Date _____

CAPACITY CLAIMED BY THE SIGNER

- Individual (s)
- Corporate Officer
- _____ (Title)
- Partner(s)
- Attorney-in-Fact
- Trustee(s)
- Other _____

INSTRUCTIONS FOR COMPLETING THIS FORM

This form complies with current California statutes regarding notary wording and, if needed, should be completed and attached to the document. Acknowledgments from other states may be completed for documents being sent to that state so long as the wording does not require the California notary to violate California notary law.

- State and County information must be the State and County where the document signer(s) personally appeared before the notary public for acknowledgment.
- Date of notarization must be the date that the signer(s) personally appeared which must also be the same date the acknowledgment is completed.
- The notary public must print his or her name as it appears within his or her commission followed by a comma and then your title (notary public).
- Print the name(s) of document signer(s) who personally appear at the time of notarization.
- Indicate the correct singular or plural forms by crossing off incorrect forms (i.e. ~~he~~/she/~~they~~, ~~is~~ /are) or circling the correct forms. Failure to correctly indicate this information may lead to rejection of document recording.
- The notary seal impression must be clear and photographically reproducible. Impression must not cover text or lines. If seal impression smudges, re-seal if a sufficient area permits, otherwise complete a different acknowledgment form.
- Signature of the notary public must match the signature on file with the office of the county clerk.
 - ❖ Additional information is not required but could help to ensure this acknowledgment is not misused or attached to a different document.
 - ❖ Indicate title or type of attached document, number of pages and date.
 - ❖ Indicate the capacity claimed by the signer. If the claimed capacity is a corporate officer, indicate the title (i.e. CEO, CFO, Secretary).
- Securely attach this document to the signed document with a staple.

**CITY OF BEAUMONT
PUBLIC WORKS AGREEMENT**

EXHIBIT "A"

INVITATION FOR BIDS



Website:
<http://beaumontca.gov/>

Address:
550 E. 6th Street
Beaumont, CA 92223

Phone:
951.769.8520

**REQUEST FOR BID
FOR:
CITYWIDE SIDEWALK IMPROVEMENTS CIP R-24**

FEBRUARY 22, 2024

CRITICAL BID DATES, TIMES, & LOCATIONS

Bid Published:	February 22, 2024
Mandatory Pre-Bid Meeting:	March 6, 2024 @ 10:00 A.M.
Bids Must Be Received By:	April 4, 2024 @ 11:00 A.M.
Place Of Bid Receipt:	550 E. Sixth Street (City Hall)
Questions In By:	March 12, 2024 @ 11:00 A.M.
Bid Opening Date:	April 4, 2024 @ 11:05 A.M.
Bid Opening Location:	550 E. Sixth Street (City Hall), Room 4

CONTACTS:

Raveena Chara
Procurement and Contracts Specialist
rchara@beaumontca.gov

RFB AVAILABLE:

WWW.PUBLICPURCHASE.COM
[HTTPS://WWW.BEAUMONTCA.GOV/949/BIDS-AND-RFPs](https://WWW.BEAUMONTCA.GOV/949/BIDS-AND-RFPs)



**CITY OF BEAUMONT
CALIFORNIA
PUBLIC WORKS DEPARTMENT
CONTRACT DOCUMENTS & SPECIFICATIONS**

FOR:

CITYWIDE SIDEWALK IMPROVEMENTS CIP R-24

Prepared Under the Supervision of:

Robert Vestal, P.E., Public Works Director/City Engineer

02/22/2024

Date



TABLE OF CONTENTS

NOTICE INVITING BIDS.....	1
INSTRUCTIONS TO BIDDERS	4
BID FORM	12
BASE BID	14
BID SCHEDULE.....	14
ADDITIVE BID A.....	15
BID SCHEDULE.....	15
ADDITIVE BID B.....	16
BID SCHEDULE.....	16
ADDITIVE BID C.....	17
BID SCHEDULE.....	17
ADDITIVE BID D.....	18
BID SCHEDULE.....	18
ADDITIVE BID E.....	19
BID SCHEDULE.....	19
ADDITIVE BID F	20
BID SCHEDULE.....	20
ADDITIVE BID G.....	21
BID SCHEDULE.....	21
BID CERTIFICATION	23
CONTRACTOR’S CERTIFICATE REGARDING WORKERS’ COMPENSATION	24
BID BOND	25
DESIGNATION OF SUBCONTRACTORS.....	28
INFORMATION REQUIRED OF BIDDERS	30
NON-COLLUSION AFFIDAVIT	37
PERFORMANCE BOND.....	38
THIS IS A REQUIRED FORM.....	41
PAYMENT BOND	43
02 GENERAL CONDITIONS	45



03 SPECIAL FEDERAL PROVISIONS.....	46
04 SPECIAL CONDITIONS	47
05 TECHNICAL SPECIFICATIONS.....	48
06 CONTRACT DRAWINGS	49
07 PUBLIC WORKS AGREEMENT	50
08 APPENDICES	51



NOTICE INVITING BIDS

The City of Beaumont, Public Works Department (“City”) is soliciting bids for:

CITYWIDE SIDEWALK IMPROVEMENTS CIP R-24

BID DATES, TIMES, & LOCATIONS:

Bid Published:	February 22, 2024
Mandatory Pre-Bid Meeting:	March 6, 2024 @ 10:00 A.M. at City Hall Conference Room 4
Bids Must Be Received By:	April 4, 2024 @ 11:00 A.M.
Place Of Bid Receipt:	550 E. Sixth Street (City Hall) Beaumont, CA 92223
Questions In By:	March 12, 2024 @ 11:00 A.M.
Bid Opening Date:	April 4, 2024 @ 11:05 A.M.
Bid Opening Location:	550 E. Sixth Street (City Hall), Room 4 Beaumont, CA 92223

Bids received after this time will be discarded. Bids shall be valid for 90 calendar days after the bid opening date. Bids must be submitted on the City’s Bid Forms. Bids must be prepared on the approved Bid forms and in the manner prescribed in the Instructions to Bidders. Bids must be submitted with the following subject:

“CITYWIDE SIDEWALK IMPROVEMENTS CIP R-24”

LOCATION OF WORK:

The work to be completed is located on various streets throughout the City and defined in the Construction Plans.

DESCRIPTION OF WORK:

The proposed work shall be performed in accordance with the contract documents, including but not limited to the general conditions, special conditions, technical specifications, contract drawings, permits, and all other reference documents.

In general, the work includes, but is not limited to the installation of sidewalks in select streets throughout the City as defined in the construction plans, as well as new driveway approaches, new curb ramps, tree removal, mailbox relocation, removal of landscaping, adjustment of property elevations, etc.

CONTRACT LENGTH:

The work for this contract shall not exceed **120 calendar days**. Contract time shall commence upon issuance of the Notice to Proceed from the City. If The Work is not



completed as stated in the Contract Documents, there will be liquidated damages in a sum of \$2,000 per calendar day as stated in General Conditions, Article 43.

AWARD OF CONTRACT:

The City shall award the Contract for the Project to the lowest responsive, responsible bidder as determined from a total bid price that includes the base bid and the most additive bid items while not exceeding the contract award limit. Additive bid items will be awarded in order of priority from A to G as presented in the bid schedule. The total bid price will include the base bid and any additive bid items, added in order of priority, that can be completed while not exceeding the contract award limit. For this project the contract award limit is \$520,000. The City reserves the right to reject any or all bids or to waive any irregularities or informalities in any bids or in the bidding process. A Pre-Construction meeting will be scheduled with the selected bidder after the construction contract is awarded.

The City of Beaumont hereby affirmatively ensures that minority business enterprises will be afforded full opportunity to submit Bids in response to this Notice, and that minorities nor minority business enterprises will not be discriminated against on the basis of race, color, national origin, ancestry, sex, or religion in any consideration leading to the award of contract. For further information, please see the form titled "Notice of Requirement for Affirmative Action to Ensure Equal Employment Opportunity (Executive Order 11246)" within the Bid Documents.

CONTRACT DOCUMENTS AND SPECIFICATION:

Copies of the Contract Documents and Specification are available for inspection at no cost to the bidder at City Hall. The documents can also be downloaded from the City's Website (<https://www.beaumontca.gov>) and WWW.PUBLICPURCHASE.COM and reviewed at no cost.

BID & BIDDER:

Bids must be accompanied by cash, a certified or cashier's check, or a Bid Bond in favor of the City in an amount not less than ten percent (10%) of the submitted Total Bid Price.

Each bid shall be accompanied by the security referred to in the Contract Documents, the non-collusion affidavit, the list of proposed subcontractors, and all additional documentation required by the Instructions to Bidders.

The successful bidder will be required to furnish the City with a Performance Bond equal to 100% of the successful bid, and a Payment (Labor and Materials) Bond equal to 100% of the successful bid, prior to execution of the Contract. All bonds are to be secured from a surety that meets all of the State of California bonding requirements, as defined in Code of Civil Procedure Section 995.120, and is admitted by the State of California.

Each bidder shall be a licensed contractor pursuant to the Business and Professions

NOTICE INVITING BIDS



Code and shall be licensed in the following appropriate classification(s) of contractor's license(s), for the work bid upon, and must maintain the license(s) throughout the duration of the Contract:

- California Class "A" and/or required Class "C" licenses

FEDERAL FUNDING

This project is being financed with Community Development Block Grant funds from the U.S. Department of Housing and Urban Development (24 CFR Part 570) and subject to certain requirements including: compliance with *Section 3 (24 CFR Part 75)* Economic Opportunities requirements; payment of Federal Davis-Bacon prevailing wages; Federal Labor Standards Provisions (HUD 4010); Executive Order #11246; and others. Information pertaining to the Federal requirements is on file with the County of Riverside Department of Housing Homelessness Prevention and Workforce Solutions.

PREVAILING WAGES

Pursuant to Section 1773 of the Labor Code, the general prevailing wage rates, including the per diem wages applicable to the work, and for holiday and overtime work, including employer payments for health and welfare, pension, vacation, and similar purposes, in the County of Riverside in which the work is to be done, have been determined by the Director of the Department of Industrial Relations, State of California. These wages are set forth in the General Prevailing Wage Rates for this project, available from the California Department of Industrial Relations' Internet web site at www.dir.ca.gov. Future effective prevailing wage rates which have been predetermined, and are on file with the California Department of Industrial Relations, are referenced but not printed in the general prevailing wage rates.

The Federal minimum wage rate requirements, as predetermined by the U.S. Secretary of Labor, are set forth in the books issued for bidding purposes, referred to herein as Project Bid Documents (Special Federal Provisions), and in copies of this book which may be examined at the office described above where the project plans, special provisions, and proposal forms may be seen. Addenda to modify the minimum wage rates, if necessary, will be issued to holders of the Project Bid Documents.

FOR FURTHER INFORMATION CONTACT:

Raveena Chara

E-mail: rchara@beaumontca.gov



INSTRUCTIONS TO BIDDERS

AVAILABILITY OF CONTRACT DOCUMENTS:

Bids must be submitted to the City on the Bid Forms which are a part of the Bid Package for the Project. Prospective bidders may obtain one (1) complete set of Contract Documents at no cost. Contract Documents may be obtained from the City at the location(s) and at the time(s) indicated in the Notice Inviting Bids. Prospective bidders are encouraged to telephone in advance to determine the availability of Contract Documents. Any applicable charges for the Contract Documents are outlined in the Notice Inviting Bids. The City may also make the Contract Documents available for review at one or more plan rooms, as indicated in the Notice Inviting Bids. Please Note: Prospective bidders who choose to review the Contract Documents at a plan room must contact the City to obtain the required Contract Documents if they decide to submit a bid for the Project.

EXAMINATION OF CONTRACT DOCUMENTS:

The City has made copies of the Contract Documents available, as indicated above. Bidders shall be solely responsible for examining the Project Site and the Contract Documents, including any Addenda issued during the bidding period, and for informing itself with respect to local labor availability, means of transportation, necessity for security, laws and codes, local permit requirements, wage scales, local tax structure, contractors' licensing requirements, availability of required insurance, and other factors that could affect the Work. Bidders are responsible for consulting the standards referenced in the Contract. Failure of Bidder to so examine and inform itself shall be at its sole risk, and no relief for error or omission will be given except as required under State law.

INTERPRETATION OF CONTRACT DOCUMENTS

Discrepancies in, and/or omissions from the Plans, Specifications or other Contract Documents or questions as to their meaning shall be immediately brought to the attention of the City by submission of a written request for an interpretation or correction to the City. Such submission, if any, must be sent to the Project Manager by faxing (951)769-8526 or emailing to dchristensn@beaumontca.gov. Any interpretation of the Contract Documents will be made only by written addenda duly issued and mailed or delivered to each person or firm who has purchased a set of Contract Documents. The City will not be responsible for any explanations or interpretations provided in any other manner. No person is authorized to make any oral interpretation of any provision in the Contract Documents to any bidder, and no bidder should rely on any such oral interpretation. Bids shall include complete compensation for all items that are noted in the Contract Documents as the responsibility of the Contractor.

INSPECTION OF SITE:

Each prospective bidder is responsible for fully acquainting itself with the conditions of the Project Site (which may include more than one site), as well as those relating to the

INSTRUCTIONS TO BIDDERS



construction and labor of the Project, to fully understand the facilities, difficulties and restrictions which may impact the cost or effort required to complete the Project.

ADDENDA:

The City reserves the right to revise the Contract Documents prior to the bid opening date. Revisions, if any, shall be made by written Addenda. All addenda issued by the City shall be included in the bid and made part of the Contract Documents. Pursuant to Public Contract Code Section 4104.5, if the City issues an Addendum which includes material changes to the Project less than 72 hours prior to the deadline for submission of bids, the City will extend the deadline for submission of bids. The City may determine, in its sole discretion, whether an Addendum warrants postponement of the bid submission date. Each prospective bidder shall provide City a name, address and facsimile number to which Addenda may be sent, as well as a telephone number by which the City can contact the bidder. Copies of Addenda will be furnished by facsimile, first class mail, express mail or other proper means of delivery without charge to all parties who have obtained a copy of the Contract Documents and provided such current information. Please Note: Bidders are responsible for ensuring that they have received any and all Addenda. To this end, each bidder should contact the Public Works Department to verify that he has received all Addenda issued, if any, prior to the bid opening.

ADDITIVE BID ITEMS

Additive bid items are called for in the Contract Documents. The lowest bid shall be determined from a total bid price that includes the base bid and the most additive bid items while not exceeding the contract award limit. Additive bid items will be awarded in order of priority from A to G as presented in the bid schedule. The total bid price will include the base bid and any additive bid items, added in order of priority, that can be completed while not exceeding the contract award limit. For this project the contract award limit is \$520,000. The time required for completion of the additive bid items has been factored into the Contract duration and no additional Contract time will be awarded for any of the additive bid items. The City may elect to include one or more of the additive bid items, or to otherwise remove certain work from the Project scope of work, accordingly each Bidder must ensure that each bid item contains a proportionate share of profit, overhead and other costs or expenses which will be incurred by the Bidder.

COMPLETION OF BID FORMS

Bids shall only be prepared using copies of the Bid Forms which are included in the Contract Documents. The use of substitute bid forms other than clear and correct photocopies of those provided by the City will not be permitted. Bids shall be executed by an authorized signatory as described in these Instructions to Bidders. In addition, Bidders shall fill in all blank spaces (including inserting "N/A" where applicable) and initial all interlineations, alterations, or erasures to the Bid Forms. Bidders shall neither delete, modify, nor supplement the printed matter on the Bid Forms nor make substitutions thereon. **USE OF BLACK OR BLUE INK, INDELIBLE PENCIL, COMPUTER OR A TYPEWRITER IS REQUIRED.** Deviations in the bid form may result in the bid being

INSTRUCTIONS TO BIDDERS



deemed non-responsive.

MODIFICATIONS OF BIDS:

Each Bidder shall submit its Bid in strict conformity with the requirements of the Contract Documents. Unauthorized additions, modifications, revisions, conditions, limitations, exclusions or provisions attached to a Bid may render it non-responsive and may cause its rejection. Bidders shall neither delete, modify, nor supplement the printed matter on the Bid Forms, nor make substitutions thereon. Oral, telephonic and electronic modifications will not be considered, unless the Notice Inviting Bids authorizes the submission of electronic bids and modifications thereto and such modifications are made in accordance with the Notice Inviting Bids.

DESIGNATION OF SUBCONTRACTORS:

Pursuant to the funding regulation, the Bidders must designate the name and location of each subcontractor who will perform work or render services for in excess of one-half of 1 percent of the prime contractor's total bid or ten thousand dollars (\$10,000), whichever is greater, as well as the portion of work each such subcontractor will perform on the form provided herein by the City. No additional time will be provided to bidders to submit any of the requested information in the Designation of Subcontractor form.

LICENSING REQUIREMENTS:

Pursuant to Section 7028.15 of the Business and Professions Code and Section 3300 of the Public Contract Code, all bidders must possess proper licenses for performance of this Contract. Subcontractors must possess the appropriate licenses for each specialty subcontracted. Pursuant to Section 7028.5 of the Business and Professions Code, the City shall consider any bid submitted by a contractor not currently licensed in accordance with state law and pursuant to the requirements found in the Contract Documents to be nonresponsive, and the City shall reject the Bid. The City shall have the right to request, and Bidders shall provide within five (5) calendar days, evidence satisfactory to the City of all valid license(s) currently held by that Bidder and each of the Bidder's subcontractors, before awarding the Contract. Please also note that, pursuant to Public Contract Code Section 20676, sellers of "mined material" must be on an approved list of sellers published pursuant to Public Resources Code Section 2717(b) in order to supply mined material for this Contract.

SIGNING OF BIDS:

All Bids submitted shall be executed by the Bidder or its authorized representative. Bidders may be asked to provide evidence in the form of an authenticated resolution of its Board of Directors or a Power of Attorney evidencing the capacity of the person signing the Bid to bind the Bidder to each Bid and to any Contract arising therefrom. If a Bidder is a joint venture or partnership, it may be asked to submit an authenticated Power of Attorney executed by each joint venturer or partner appointing and designating one of the joint venturers or partners as a management sponsor to execute the Bid on behalf of Bidder. Only that joint venturer or partner shall execute the Bid. The Power of Attorney

INSTRUCTIONS TO BIDDERS



shall also: (1) authorize that particular joint venturer or partner to act for and bind Bidder in all matters relating to the Bid; and (2) provide that each venturer or partner shall be jointly and severally liable for any and all of the duties and obligations of Bidder assumed under the Bid and under any Contract arising therefrom. The Bid shall be executed by the designated joint venturer or partner on behalf of the joint venture or partnership in its legal name.

BID GUARANTEE (BOND):

Each bid shall be accompanied by: (a) cash; (b) a certified check made payable to the City; (c) a cashier's check made payable to the City; or (d) a bid bond payable to the City executed by the bidder as principal and surety as obligor in an amount not less than 10% of the maximum amount of the bid. Personal sureties and unregistered surety companies are unacceptable. The surety insurer shall be California admitted surety insurer, as defined in Code of Civil Procedure Section 995.120. The cash, check or bid bond shall be given as a guarantee that the bidder shall execute the Contract if it be awarded to the bidder, shall provide the payment and performance bonds and insurance certificates and endorsements as required herein within ten (10) calendar days after notification of the award of the Contract to the bidder. Failure to provide the required documents may result in forfeiture of the bidder's bid deposit or bond to the City and the City may award the Contract to the next lowest responsive, responsible bidder, or may call for new bids.

SUBMISSION OF BIDS:

Once the Bid and supporting documents have been completed and signed as set forth herein, they shall be mailed or hand delivered to the City at the place and to the attention of the person indicated in the Notice Inviting Bids. No oral or telephonic bids will be considered. No forms transmitted via facsimile, or any other electronic means will be considered unless specifically authorized by City as provided herein.

Only where expressly permitted in the Notice Inviting Bids, may Bidders submit their bids via electronic transmission pursuant to Public Contract Code Sections 1600 and 1601. The acceptable method(s) of electronic transmission shall be stated in the Notice Inviting Bids. City reserves the right to not accept electronically transmitted bids where not specifically authorized in the Notice Inviting Bids, and may reject any bid not strictly complying with City's designated methods for delivery.

DELIVERY AND OPENING OF BIDS

Bids will be received by the City at the address shown in the Notice Inviting Bids up to the date and time shown therein. It is the Bidder's sole responsibility to ensure that its Bid is received as specified. Bids may be submitted earlier than the dates(s) and time(s) indicated.

Bids will be opened at the date and time stated in the Notice Inviting Bids, and the amount of each Bid will be read aloud and recorded. All Bidders may, if they desire, attend the opening of Bids at the address specified in the NIB. The City may in its sole discretion, elect to postpone the opening of the submitted Bids. City reserves the right to reject any

INSTRUCTIONS TO BIDDERS



or all Bids and to waive any informality or irregularity in any Bid. In the event of a discrepancy between the written amount of the Bid Price and the numerical amount of the Bid Price, the written amount shall govern.

WITHDRAWAL OF BID:

Prior to bid opening, a Bid may be withdrawn by the Bidder only by means of a written request signed by the Bidder or its properly authorized representative.

BASIS OF AWARD; BALANCED BIDS:

The City shall award the Contract to the lowest responsive, responsible Bidder submitting a responsive Bid. The City may reject any Bid which, in its opinion when compared to other bids received or to the City's internal estimates, does not accurately reflect the cost to perform the Work. The City may reject as non-responsive any bid which unevenly weights or allocates costs, including but not limited to overhead and profit to one or more particular bid items.

DISQUALIFICATION OF BIDDERS; INTEREST IN MORE THAN ONE BID:

No bidder shall be allowed to make, submit or be interested in more than one bid. However, a person, firm, corporation or other entity that has submitted a subproposal to a bidder, or that has quoted prices of materials to a bidder, is not thereby disqualified from submitting a subproposal or quoting prices to other bidders submitting a bid to the City. No person, firm, corporation, or other entity may submit subproposal to a bidder, or quote prices of materials to a bidder, when also submitting a prime bid on the same Project.

INSURANCE REQUIREMENTS:

The successful bidder shall procure the insurance in the form and in the amount specified in the Contract Documents.

AWARD PROCESS:

Once all Bids are opened and reviewed to determine the lowest responsive and responsible Bidder, the City Council may award the contract. The apparent successful Bidder should begin to prepare the following documents: (1) the Performance Bond; (2) the Payment (Labor and Materials) Bond; and (3) the required insurance certificates and endorsements. Once the City notifies the Bidder of the award, the Bidder will have ten (10) consecutive calendar days from the date of this notification to execute the Contract and supply the City with all of the required documents and certifications. Regardless whether the Bidder supplies the required documents and certifications in a timely manner, the Contract time will begin to run ten (10) calendar days from the date of the notification. Once the City receives all of the properly drafted and executed documents and certifications from the Bidder, the City shall issue a Notice to Proceed to that Bidder.

FILING OF BID PROTESTS

Bidders may file a "protest" of a Bid with the City's City Engineer. In order for a Bidder's protest to be considered valid, the protest must:

INSTRUCTIONS TO BIDDERS



- Be filed in writing within five (5) calendar days after the bid opening date;
- Clearly identify the specific irregularity or accusation;
- Clearly identify the specific City staff determination or recommendation being protested;
- Specify, in detail, the grounds of the protest and the facts supporting the protest; and
- Include all relevant, supporting documentation with the protest at time of filing.

If the protest does not comply with each of these requirements, it will be rejected as invalid. If the protest is valid, the City's City Engineer, or other designated City staff member, shall review the basis of the protest and all relevant information. The City Engineer will provide a written decision to the protestor. The protestor may then appeal the decision of the City Engineer to the City Manager.

WORKERS COMPENSATION:

Each bidder shall submit the Contractor's Certificate Regarding Workers' Compensation form.

SUBSTITUTION OF SECURITY:

The Contract Documents call for monthly progress payments based upon the percentage of the work completed. The City will retain five percent (5%) of each progress payment as provided by the Contract Documents. At the request and expense of the successful Bidder, the City will substitute securities for the amount so retained in accordance with Public Contract Code Section 22300.

PREVAILING WAGES:

Pursuant to Section 1773 of the Labor Code, the general prevailing wage rates, including the per diem wages applicable to the work, and for holiday and overtime work, including employer payments for health and welfare, pension, vacation, and similar purposes, in the County of Riverside in which the work is to be done, have been determined by the Director of the Department of Industrial Relations, State of California. These wages are set forth in the General Prevailing Wage Rates for this project, available from the California Department of Industrial Relations' Internet web site at www.dir.ca.gov. Future effective prevailing wage rates which have been predetermined, and are on file with the California Department of Industrial Relations, are referenced but not printed in the general prevailing wage rates. Pursuant to SB 854, which amended the Prevailing Wage Laws, this Contract is subject to compliance monitoring and enforcement by the DIR. Beginning March 1, 2015, with very limited exceptions, no contractor or subcontractor may be listed on a bid proposal for this Contract unless registered with the DIR pursuant to Labor Code section 1725.5. Beginning April 1, 2015, no contractor or subcontractor may be awarded this Contract unless registered with the DIR pursuant to Labor Code section 1725.5. The DIR registration number for each contractor and subcontractor must be identified on the bid proposal - failure to identify this number could result in the bid being rejected as non-responsive. It is each bidder's responsibility to ensure that they have fully complied with



SB 854. The City will report all necessary contracts to the DIR as required by the Prevailing Wage Laws.

DEBARMENT OF CONTRACTORS AND SUBCONTRACTORS:

In accordance with the provisions of the Labor Code, contractors or subcontractors may not perform work on a public works project with a subcontractor who is ineligible to perform work on a public project pursuant to Section 1777.1 or Section 1777.7 of the Labor Code. Any contract on a public works project entered into between a contractor and a debarred subcontractor is void as a matter of law. A debarred subcontractor may not receive any public money for performing work as a subcontractor on a public works contract. Any public money that is paid to a debarred subcontractor by the Contractor for the Project shall be returned to the City. The Contractor shall be responsible for the payment of wages to workers of a debarred subcontractor who has been allowed to work on the Project.

PERFORMANCE AND PAYMENT BOND REQUIREMENTS:

Within the time specified in the Contract Documents, the Bidder to whom a Contract is awarded shall deliver to the City four identical counterparts of the Performance Bond and Payment (Labor and Materials) Bond in the form supplied by the City and included in the Contract Documents. Failure to do so may, in the sole discretion of City, result in the forfeiture of the Bid Guarantee. The surety supplying the bond must be an admitted surety insurer, as defined in Code of Civil Procedure Section 995.120, authorized to do business as such in the State of California and satisfactory to the City. The Performance Bond and the Payment (Labor and Materials) Bond shall be for one hundred percent (100%) of the Total Bid Price.

REQUEST FOR SUBSTITUTIONS

The successful bidder shall comply with the substitution request provisions set forth in the Special Conditions, including any deadlines for substitution requests which may occur prior to the bid opening date.

SALES AND OTHER APPLICABLE TAXES, PERMITS, LICENSES AND FEES

Contractor and its subcontractors performing work under this Contract will be required to pay California sales tax and other applicable taxes, and to pay for permits, licenses and fees required by the agencies with authority in the jurisdiction in which the work will be located, unless otherwise expressly provided by the Contract Documents.

EXECUTION OF CONTRACT

As required herein the Bidder to whom an award is made shall execute the Contract in the amount determined by the Contract Documents. The City may require appropriate evidence that the persons executing the Contract are duly empowered to do so.

END OF INSTRUCTIONS TO BIDDERS

INSTRUCTIONS TO BIDDERS





BID FORM

NAME OF BIDDER: _____

The undersigned, hereby declare that we have carefully examined the location of the proposed Work, and have read and examined the Contract Documents, including all plans, specifications, and all addenda, if any, for the following Project:

CITYWIDE SIDEWALK IMPROVEMENTS CIP R-24

We hereby propose to furnish all labor, materials, equipment, tools, transportation, and services, and to discharge all duties and obligations necessary and required to perform and complete the Project for the following TOTAL BID PRICE:

BASE BID	BASE BID PRICE (IN WRITTEN FORM)	BID PRICE (IN NUMBERS)
BASE BID (Massachusetts)		
ADDITIVE A (Magnolia)		
ADDITIVE B (Elm)		
ADDITIVE C (Chestnut)		
ADDITIVE D (N. California)		
ADDITIVE E (Wellwood)		



ADDITIVE F (Edgar)		
ADDITIVE G (Euclid)		
TOTAL BID PRICE		

In case of discrepancy between the written price and the numerical price, the written price shall prevail.



BASE BID
BID SCHEDULE
CITYWIDE SIDEWALK IMPROVEMENTS CIP R-24

MASSACHUSETTS AVENUE

ITEM NO.	DESCRIPTION OF ITEMS	EST. QUANTITY/ UNIT		UNIT PRICE (FIGURES)	TOTAL COST (FIGURES)
1	TEMPORARY CONSTRUCTION SIGN	2	EA		
2	INSTALL NEW SIDEWALK	1410	LF		
3	PCC PAVEMENT (DRIVEWAY APPROACH)	42	EA		
4	REMOVE TREE (LARGE)	3	EA		
5	REMOVE TREE (SMALL)	2	EA		
6	REMOVE CONCRETE (EXISTING DRIVEWAY APPROACH)	38	EA		
7	REMOVE CONCRETE (EXISTING SIDEWALK)	40	LF		
8	REMOVE CONCRETE (EXISTING CURB & GUTTER)	0	LF		
9	RELOCATE MAILBOX	29	EA		
10	CURB INLET CATCH BASIN	0	EA		
11	CURB OUTLET DRAIN	0	EA		
12	MINOR CONCRETE (CURB RAMP CASE A)	0	EA		
13	MINOR CONCRETE (CURB RAMP CASE B)	0	EA		
14	MINOR CONCRETE (CURB RAMP CASE C)	2	EA		
15	CURB RAMP DETECTABLE WARNING SURFACE	0	EA		
16	INSTALL NEW CURB & GUTTER	120	LF		
17	RELOCATE CANDLESTICK LIGHT POLE	1	EA		
19	ADJUST WATER SERVICE METER BOX ELEVATION	20	EA		
PROJECT BASE BID SUBTOTAL:					



ADDITIVE BID A
BID SCHEDULE
CITYWIDE SIDEWALK IMPROVEMENTS CIP R-24

MAGNOLIA AVENUE

ITEM NO.	DESCRIPTION OF ITEMS	EST. QUANTITY/ UNIT		UNIT PRICE (FIGURES)	TOTAL COST (FIGURES)
1	TEMPORARY CONSTRUCTION SIGN	2	EA		
2	INSTALL NEW SIDEWALK	1120	LF		
3	PCC PAVEMENT (DRIVEWAY APPROACH)	29	EA		
4	REMOVE TREE (LARGE)	0	EA		
5	REMOVE TREE (SMALL)	0	EA		
6	REMOVE CONCRETE (EXISTING DRIVEWAY APPROACH)	24	EA		
7	REMOVE CONCRETE (EXISTING SIDEWALK)	80	LF		
8	REMOVE CONCRETE (EXISTING CURB & GUTTER)	50	LF		
9	RELOCATE MAILBOX	15	EA		
10	CURB INLET CATCH BASIN	0	EA		
11	CURB OUTLET DRAIN	0	EA		
12	MINOR CONCRETE (CURB RAMP CASE A)	1	EA		
13	MINOR CONCRETE (CURB RAMP CASE B)	1	EA		
14	MINOR CONCRETE (CURB RAMP CASE C)	4	EA		
15	CURB RAMP DETECTABLE WARNING SURFACE	0	EA		
16	INSTALL NEW CURB & GUTTER	640	LF		
17	RELOCATE CANDLESTICK LIGHT POLE	0	EA		
19	ADJUST WATER SERVICE METER BOX ELEVATION	3	EA		
ADDITIVE A SUBTOTAL:					



ADDITIVE BID B
BID SCHEDULE
CITYWIDE SIDEWALK IMPROVEMENTS CIP R-24

ELM AVENUE

ITEM NO.	DESCRIPTION OF ITEMS	EST. QUANTITY/ UNIT		UNIT PRICE (FIGURES)	TOTAL COST (FIGURES)
1	TEMPORARY CONSTRUCTION SIGN	2	EA		
2	INSTALL NEW SIDEWALK	1500	LF		
3	PCC PAVEMENT (DRIVEWAY APPROACH)	20	EA		
4	REMOVE TREE (LARGE)	8	EA		
5	REMOVE TREE (SMALL)	0	EA		
6	REMOVE CONCRETE (EXISTING DRIVEWAY APPROACH)	16	EA		
7	REMOVE CONCRETE (EXISTING SIDEWALK)	30	LF		
8	REMOVE CONCRETE (EXISTING CURB & GUTTER)	235	LF		
9	RELOCATE MAILBOX	16	EA		
10	CURB INLET CATCH BASIN	2	EA		
11	CURB OUTLET DRAIN	0	EA		
12	MINOR CONCRETE (CURB RAMP CASE A)	3	EA		
13	MINOR CONCRETE (CURB RAMP CASE B)	2	EA		
14	MINOR CONCRETE (CURB RAMP CASE C)	1	EA		
15	CURB RAMP DETECTABLE WARNING SURFACE	1	EA		
16	INSTALL NEW CURB & GUTTER	265	LF		
17	RELOCATE CANDLESTICK LIGHT POLE	2	EA		
19	ADJUST WATER SERVICE METER BOX ELEVATION	3	EA		
ADDITIVE B SUBTOTAL:					



ADDITIVE BID C
BID SCHEDULE
CITYWIDE SIDEWALK IMPROVEMENTS CIP R-24

CHESTNUT ANENUE

ITEM NO.	DESCRIPTION OF ITEMS	EST. QUANTITY/ UNIT		UNIT PRICE (FIGURES)	TOTAL COST (FIGURES)
1	TEMPORARY CONSTRUCTION SIGN	2	EA		
2	INSTALL NEW SIDEWALK	1530	LF		
3	PCC PAVEMENT (DRIVEWAY APPROACH)	31	EA		
4	REMOVE TREE (LARGE)	8	EA		
5	REMOVE TREE (SMALL)	2	EA		
6	REMOVE CONCRETE (EXISTING DRIVEWAY APPROACH)	31	EA		
7	REMOVE CONCRETE (EXISTING SIDEWALK)	80	LF		
8	REMOVE CONCRETE (EXISTING CURB & GUTTER)	10	LF		
9	RELOCATE MAILBOX	30	EA		
10	CURB INLET CATCH BASIN	0	EA		
11	CURB OUTLET DRAIN	0	EA		
12	MINOR CONCRETE (CURB RAMP CASE A)	2	EA		
13	MINOR CONCRETE (CURB RAMP CASE B)	1	EA		
14	MINOR CONCRETE (CURB RAMP CASE C)	0	EA		
15	CURB RAMP DETECTABLE WARNING SURFACE	1	EA		
16	INSTALL NEW CURB & GUTTER	70	LF		
17	RELOCATE CANDLESTICK LIGHT POLE	1	EA		
19	ADJUST WATER SERVICE METER BOX ELEVATION	20	EA		
ADDITIVE C SUBTOTAL:					



ADDITIVE BID D
BID SCHEDULE
CITYWIDE SIDEWALK IMPROVEMENTS CIP R-24

N. CALIFORNIA AVENUE

ITEM NO.	DESCRIPTION OF ITEMS	EST. QUANTITY/ UNIT		UNIT PRICE (FIGURES)	TOTAL COST (FIGURES)
1	TEMPORARY CONSTRUCTION SIGN	2	EA		
2	INSTALL NEW SIDEWALK	1350	LF		
3	PCC PAVEMENT (DRIVEWAY APPROACH)	23	EA		
4	REMOVE TREE (LARGE)	7	EA		
5	REMOVE TREE (SMALL)	6	EA		
6	REMOVE CONCRETE (EXISTING DRIVEWAY APPROACH)	20	EA		
7	REMOVE CONCRETE (EXISTING SIDEWALK)	120	LF		
8	REMOVE CONCRETE (EXISTING CURB & GUTTER)	0	LF		
9	RELOCATE MAILBOX	20	EA		
10	CURB INLET CATCH BASIN	0	EA		
11	CURB OUTLET DRAIN	0	EA		
12	MINOR CONCRETE (CURB RAMP CASE A)	3	EA		
13	MINOR CONCRETE (CURB RAMP CASE B)	0	EA		
14	MINOR CONCRETE (CURB RAMP CASE C)	12	EA		
15	CURB RAMP DETECTABLE WARNING SURFACE	1	EA		
16	INSTALL NEW CURB & GUTTER	350	LF		
17	RELOCATE CANDLESTICK LIGHT POLE	1	EA		
19	ADJUST WATER SERVICE METER BOX ELEVATION	2	EA		
ADDITIVE D SUBTOTAL:					



ADDITIVE BID E
BID SCHEDULE
CITYWIDE SIDEWALK IMPROVEMENTS CIP R-24

WELLWOOD AVENUE

ITEM NO.	DESCRIPTION OF ITEMS	EST. QUANTITY/ UNIT		UNIT PRICE (FIGURES)	TOTAL COST (FIGURES)
1	TEMPORARY CONSTRUCTION SIGN	2	EA		
2	INSTALL NEW SIDEWALK	1400	LF		
3	PCC PAVEMENT (DRIVEWAY APPROACH)	42	EA		
4	REMOVE TREE (LARGE)	4	EA		
5	REMOVE TREE (SMALL)	2	EA		
6	REMOVE CONCRETE (EXISTING DRIVEWAY APPROACH)	35	EA		
7	REMOVE CONCRETE (EXISTING SIDEWALK)	50	LF		
8	REMOVE CONCRETE (EXISTING CURB & GUTTER)	0	LF		
9	RELOCATE MAILBOX	17	EA		
10	CURB INLET CATCH BASIN	1	EA		
11	CURB OUTLET DRAIN	1	EA		
12	MINOR CONCRETE (CURB RAMP CASE A)	5	EA		
13	MINOR CONCRETE (CURB RAMP CASE B)	0	EA		
14	MINOR CONCRETE (CURB RAMP CASE C)	10	EA		
15	CURB RAMP DETECTABLE WARNING SURFACE	0	EA		
16	INSTALL NEW CURB & GUTTER	200	LF		
17	RELOCATE CANDLESTICK LIGHT POLE	2	EA		
19	ADJUST WATER SERVICE METER BOX ELEVATION	3	EA		
ADDITIVE E SUBTOTAL:					



ADDITIVE BID F
BID SCHEDULE
CITYWIDE SIDEWALK IMPROVEMENTS CIP R-24

EDGAR AVENUE

ITEM NO.	DESCRIPTION OF ITEMS	EST. QUANTITY/ UNIT		UNIT PRICE (FIGURES)	TOTAL COST (FIGURES)
1	TEMPORARY CONSTRUCTION SIGN	2	EA		
2	INSTALL NEW SIDEWALK	2500	LF		
3	PCC PAVEMENT (DRIVEWAY APPROACH)	53	EA		
4	REMOVE TREE (LARGE)	6	EA		
5	REMOVE TREE (SMALL)	8	EA		
6	REMOVE CONCRETE (EXISTING DRIVEWAY APPROACH)	35	EA		
7	REMOVE CONCRETE (EXISTING SIDEWALK)	60	LF		
8	REMOVE CONCRETE (EXISTING CURB & GUTTER)	0	LF		
9	RELOCATE MAILBOX	22	EA		
10	CURB INLET CATCH BASIN	0	EA		
11	CURB OUTLET DRAIN	0	EA		
12	MINOR CONCRETE (CURB RAMP CASE A)	7	EA		
13	MINOR CONCRETE (CURB RAMP CASE B)	6	EA		
14	MINOR CONCRETE (CURB RAMP CASE C)	8	EA		
15	CURB RAMP DETECTABLE WARNING SURFACE	0	EA		
16	INSTALL NEW CURB & GUTTER	0	LF		
17	RELOCATE CANDLESTICK LIGHT POLE	5	EA		
19	ADJUST WATER SERVICE METER BOX ELEVATION	3	EA		
ADDITIVE F SUBTOTAL:					



ADDITIVE BID G
BID SCHEDULE
CITYWIDE SIDEWALK IMPROVEMENTS CIP R-24

EUCLID AVENUE

ITEM NO.	DESCRIPTION OF ITEMS	EST. QUANTITY/ UNIT		UNIT PRICE (FIGURES)	TOTAL COST (FIGURES)
1	TEMPORARY CONSTRUCTION SIGN	2	EA		
2	INSTALL NEW SIDEWALK	3120	LF		
3	PCC PAVEMENT (DRIVEWAY APPROACH)	53	EA		
4	REMOVE TREE (LARGE)	6	EA		
5	REMOVE TREE (SMALL)	6	EA		
6	REMOVE CONCRETE (EXISTING DRIVEWAY APPROACH)	43	EA		
7	REMOVE CONCRETE (EXISTING SIDEWALK)	350	LF		
8	REMOVE CONCRETE (EXISTING CURB & GUTTER)	0	LF		
9	RELOCATE MAILBOX	23	EA		
10	CURB INLET CATCH BASIN	0	EA		
11	CURB OUTLET DRAIN	0	EA		
12	MINOR CONCRETE (CURB RAMP CASE A)	4	EA		
13	MINOR CONCRETE (CURB RAMP CASE B)	6	EA		
14	MINOR CONCRETE (CURB RAMP CASE C)	6	EA		
15	CURB RAMP DETECTABLE WARNING SURFACE	1	EA		
16	INSTALL NEW CURB & GUTTER	80	LF		
17	RELOCATE CANDLESTICK LIGHT POLE	4	EA		
19	ADJUST WATER SERVICE METER BOX ELEVATION	7	EA		
ADDITIVE G SUBTOTAL:					



In case of discrepancy between the unit price and the item cost set forth for a unit basis item, the unit price shall prevail and, shall be utilized as the basis for determining the lowest responsive, responsible bidder. However, if the amount set forth as a unit price is ambiguous, unintelligible or uncertain for any cause, or is omitted, or is the same amount as the entry in the "Item Cost" column, then the amount set forth in the "Item Cost" column for the item shall prevail and shall be divided by the estimated quantity for the item and the price thus obtained shall be the unit price. Final payment shall be determined by the Engineer from measured quantities of work performed based upon the unit price.

In case of discrepancy between the written price and the numerical price, the written price shall prevail.



BID CERTIFICATION

Bidder certifies that it is licensed in accordance with the law providing for the registration of Contractors,

License No. _____

Expiration Date _____

Class of license _____

If the bidder is a joint venture, each member of the joint venture must include the above information.

The undersigned acknowledges receipt, understanding and full consideration of the following addenda to the Contract Documents:

1. Addenda No. _____ thru _____
2. Attached is the required bid security in the amount of not less than 10% of the Total Bid Price.
3. Attached is the fully executed Non-Collusion Affidavit form.
4. Attached is the completed Designation of Subcontractors form.
5. Attached is the completed Bidder Information Form.
6. Attached is the completed Contractor's Certificate Regarding Workers' Compensation form.

Bidder acknowledges and understands that, pursuant to Public Contract Code Section 20676, sellers of "mined material" must be on an approved list of sellers published pursuant to Public Resources Code Section 2717(b) in order to supply mined material for this Contract.

I hereby certify under penalty of perjury under the laws of the State of California, that all of the information submitted in connection with this Bid and all of the representations made herein are true and correct.

Name of Bidder _____

Signature _____

Name and Title _____

Dated _____



CONTRACTOR'S CERTIFICATE REGARDING WORKERS' COMPENSATION

CITYWIDE SIDEWALK IMPROVEMENTS CIP R-24

I am aware of the provisions of Section 3700 of the Labor Code which require every employer to be insured against liability for workers' compensation or to undertake self-insurance in accordance with the provisions of that code, and I will comply with such provisions before commencing the performance of the work of this Contract.

Name of Bidder _____

Signature _____

Name and Title _____

Dated _____



BID BOND

CITYWIDE SIDEWALK IMPROVEMENTS CIP R-24

The makers of this bond are,

_____ as Principal, and

_____, as Surety

and are held and firmly bound unto the City of Beaumont, hereinafter called the City, in the penal sum of TEN PERCENT (10%) OF THE TOTAL BID PRICE of the Principal submitted to CITY for the work described below, for the payment of which sum in lawful money of the United States, well and truly to be made, we bind ourselves, our heirs, executors, administrators, successors and assigns, jointly and severally, firmly by these presents.

THE CONDITION OF THIS OBLIGATION IS SUCH that whereas the Principal has submitted the accompanying bid dated _____, 20____, for

CITYWIDE SIDEWALK IMPROVEMENTS CIP R-24

If the Principal does not withdraw its bid within the time specified in the Contract Documents; and if the Principal is awarded the Contract and provides all documents to the City as required by the Contract Documents; then this obligation shall be null and void. Otherwise, this bond will remain in full force and effect.

Surety, for value received, hereby stipulates and agrees that no change, extension of time, alteration or addition to the terms of the Contract Documents shall in affect its obligation under this bond, and Surety does hereby waive notice of any such changes.

In the event a lawsuit is brought upon this bond by the City and judgment is recovered, the Surety shall pay all litigation expenses incurred by the City in such suit, including reasonable attorneys' fees, court costs, expert witness fees and expenses.



IN WITNESS WHEREOF, the above-bound parties have executed this instrument under their several seals this _____ day of _____, 20____, the name and corporate seal of each corporation.

(Corporate Seal)

Principal _____

By _____

Title _____

(Corporate Seal)

Surety _____

By _____

Attorney-in-Fact _____

(Attach Attorney-in-Fact Certificate)

Title _____



STATE OF CALIFORNIA)
) ss.

CITY OF _____)

On this _____ day of _____, in the year 20____, before me,
_____, a Notary Public in and for said state, personally
appeared _____, known to me to be the person
whose name is subscribed to the within instrument as the Attorney-In-Fact of the
(Surety) acknowledged to me that he subscribed the name of the

(Surety) thereto and his own name as Attorney-In-
Fact.

Notary Public in and for said State

(SEAL)

Commission expires: _____

NOTE: A copy of the Power-of-Attorney to local representatives of the bonding
company must be attached hereto.



DESIGNATION OF SUBCONTRACTORS

CITYWIDE SIDEWALK IMPROVEMENTS CIP R-24

In compliance with the Subletting and Subcontracting Fair Practices Act of the Public Contract Code of the State of California, each bidder shall set forth below: (a) the name and the location of the place of business and (b) the portion of the work which will be done by each subcontractor who will perform work or labor or render service to the Contractor in excess of one-half of 1 percent of the prime contractor's total bid or ten thousand dollars (\$10,000), whichever is greater.

Portion of the Work	Subcontractor	Location of Business	% of Work



Portion of the Work	Subcontractor	Location of Business	% of Work

Name of Bidder _____

Signature _____

Name and Title _____

Dated _____



INFORMATION REQUIRED OF BIDDERS

CITYWIDE SIDEWALK IMPROVEMENTS CIP R-24

A. INFORMATION ABOUT BIDDER

[**Indicate not applicable ("N/A") where appropriate.**]

NOTE: Where Bidder is a joint venture, pages shall be duplicated and information provided for all parties to the joint venture.

1.0 Name of Bidder: _____

2.0 Type, if Entity: _____

3.0 Bidder Address: _____

Facsimile Number

Telephone Number

4.0 License Information:

License No.

Class of License

Expiration Date

DIR Registration No.

5.0 How many years has Bidder's organization been in business as a Contractor?

5.1 How many years has Bidder's organization been in business under its present name? _____

6.0 Under what other or former names has Bidder's organization operated?

7.0 If Bidder's organization is a corporation, answer the following:

INFORMATION REQUIRED OF BIDDERS



- 7.1 Date of Incorporation: _____
- 7.2 State of Incorporation: _____
- 7.3 President's Name: _____
- 7.4 Vice-President's Name(s): _____
- 7.5 Secretary's Name: _____
- 7.6 Treasurer's Name: _____

- 8.0 If an individual or a partnership, answer the following:
 - 8.1 Date of Organization: _____
 - 8.2 Name and address of all partners (state whether general or limited partnership): _____

- 9.0 If other than a corporation or partnership, describe organization and name principals: _____

- 10.0 List other states in which Bidder's organization is legally qualified to do business.

- 11.0 What type of work does the Bidder normally perform with its own forces?

- 12.0 Has Bidder ever failed to complete any work awarded to it? If so, note when,



where, and why:

13.0 Within the last five years, has any officer or partner of Bidder's organization ever been an officer or partner of another organization when it failed to complete a contract?

If so, attach a separate sheet of explanation:

14.0 List Trade References:

15.0 List Bank References (Bank and Branch Address):

16.0 Name of Bonding Company and Name and Address of Agent:



B. LIST OF CURRENT PROJECTS (Backlog)

[**Duplicate Page if needed for listing additional current projects.**]

Project	Description of Bidder's Work	Completion Date	Cost of Bidder's Work	Contact Name & Phone



C. LIST OF COMPLETED PROJECTS - LAST THREE YEARS

[**Duplicate Page if needed for listing additional completed projects.**]

Please include only those projects which are similar enough to demonstrate Bidder's ability to perform the required Work.

Project Client	Description of Bidder's Work	Period of Performance	Cost of Bidder's Work	Contact Name & Phone



D. EXPERIENCE AND TECHNICAL QUALIFICATIONS QUESTIONNAIRE

Personnel:

The Bidder shall identify the key personnel to be assigned to this project in a management, construction supervision or engineering capacity.

1. List each person's job title, name and percent of time to be allocated to this project:

2. Summarize each person's specialized education:

3. List each person's years of construction experience relevant to the project:

4. Summarize such experience:

Bidder agrees that personnel named in this Bid will remain on this Project until completion of all relevant Work, unless substituted by personnel of equivalent experience and qualifications approved in advance by the City.



Additional Bidder's Statements:

If the Bidder feels that there is additional information which has not been included in the questionnaire above, and which would contribute to the qualification review, it may add that information in a statement here or on an attached sheet, appropriately marked:

E. VERIFICATION AND EXECUTION

These Bid Forms shall be executed only by a duly authorized official of the Bidder: I declare under penalty of perjury under the laws of the State of California that the foregoing information is true and correct:

Name of Bidder _____

Signature _____

Name and Title _____

Dated _____



NON-COLLUSION AFFIDAVIT
CITYWIDE SIDEWALK IMPROVEMENTS CIP R-24

I, _____, being first duly sworn, deposes and says that he is of _____ the party making the attached bid; that the bid is not made in the interest of, or on behalf of, any undisclosed person, partnership, company, association, organization, or corporation; that the bid is genuine and not collusive or sham; that the bidder has not directly or indirectly induced or solicited any other bidder to put in a false or sham bid, and has not directly or indirectly colluded, conspired, connived, or agreed with any bidder or anyone else to put in a sham bid, or that anyone shall refrain from bidding; that the bidder has not in any manner, directly or indirectly, sought by agreement, communication, or conference with anyone to fix the bid price of the bidder or any other bidder, or to fix any overhead, profit, or cost element of the bid price, or of that of any other bidder, or to secure any advantage against the public body awarding the contract of anyone interested in the proposed contract; that all statements contained in the bid are true; and, further, that the bidder has not, directly or indirectly, submitted his or her bid price or any breakdown thereof, or the contents thereof, or divulged information or data relative thereto, or paid, and will not pay, any fee to any corporation, partnership, company association, organization, bid depository, or to any member or agent thereof to effectuate a collusive or sham bid.

I certify (or declare) under penalty of perjury under the laws of the State of California that the foregoing is true and correct.

Name of Bidder _____

Signature _____

Name and Title _____

Dated _____



PERFORMANCE BOND

KNOW ALL PERSONS BY THESE PRESENTS:

THAT WHEREAS, _____ (hereinafter referred to as "City") has awarded to _____, (hereinafter referred to as the "Contractor") _____ an agreement for _____ (hereinafter referred to as the "Project").

WHEREAS, the work to be performed by the Contractor is more particularly set forth in the Contract Documents for the Project dated _____, (hereinafter referred to as "Contract Documents"), the terms and conditions of which are expressly incorporated herein by reference; and

WHEREAS, the Contractor is required by said Contract Documents to perform the terms thereof and to furnish a bond for the faithful performance of said Contract Documents.

NOW, THEREFORE, we, _____, the undersigned Contractor and _____ as Surety, a corporation organized and duly authorized to transact business under the laws of the State of California, are held and firmly bound unto the City in the sum of _____ DOLLARS, (\$ _____), said sum being not less than one hundred percent (100%) of the total amount of the Contract, for which amount well and truly to be made, we bind ourselves, our heirs, executors and administrators, successors and assigns, jointly and severally, firmly by these presents.

THE CONDITION OF THIS OBLIGATION IS SUCH, that, if the Contractor, his or its heirs, executors, administrators, successors or assigns, shall in all things stand to and abide by, and well and truly keep and perform the covenants, conditions and agreements in the Contract Documents and any alteration thereof made as therein provided, on its part, to be kept and performed at the time and in the manner therein specified, and in all respects according to their intent and meaning; and shall faithfully fulfill all obligations including the one-year guarantee of all materials and workmanship; and shall indemnify and save harmless the City, its officers and agents, as stipulated in said Contract Documents, then this obligation shall become null and void; otherwise it shall be and remain in full force and effect.

As a part of the obligation secured hereby and in addition to the face amount specified therefore, there shall be included costs and reasonable expenses and fees including reasonable attorney's fees, incurred by City in enforcing such obligation.

As a condition precedent to the satisfactory completion of the Contract Documents, unless otherwise provided for in the Contract Documents, the above obligation shall hold good for a period of one (1) year after the acceptance of the work by City, during which



time if Contractor shall fail to make full, complete, and satisfactory repair and replacements and totally protect the City from loss or damage resulting from or caused by defective materials or faulty workmanship. The obligations of Surety hereunder shall continue so long as any obligation of Contractor remains. Nothing herein shall limit the City's rights or the Contractor or Surety's obligations under the Contract, law or equity, including, but not limited to, California Code of Civil Procedure section 337.15.

Whenever Contractor shall be, and is declared by the City to be, in default under the Contract Documents, the Surety shall remedy the default pursuant to the Contract Documents, or shall promptly, at the City's option:

- (1) Take over and complete the Project in accordance with all terms and conditions in the Contract Documents; or
- (2) Obtain a bid or bids for completing the Project in accordance with all terms and conditions in the Contract Documents and upon determination by Surety of the lowest responsive and responsible bidder, arrange for a Contract between such bidder, the Surety and the City, and make available as work progresses sufficient funds to pay the cost of completion of the Project, less the balance of the contract price, including other costs and damages for which Surety may be liable. The term "balance of the contract price" as used in this paragraph shall mean the total amount payable to Contractor by the City under the Contract and any modification thereto, less any amount previously paid by the City to the Contractor and any other set offs pursuant to the Contract Documents.
- (3) Permit the City to complete the Project in any manner consistent with California law and make available as work progresses sufficient funds to pay the cost of completion of the Project, less the balance of the contract price, including other costs and damages for which Surety may be liable. The term "balance of the contract price" as used in this paragraph shall mean the total amount payable to Contractor by the City under the Contract and any modification thereto, less any amount previously paid by the City to the Contractor and any other set offs pursuant to the Contract Documents.

Surety expressly agrees that the City may reject any contractor or subcontractor which may be proposed by Surety in fulfillment of its obligations in the event of default by the Contractor.

Surety shall not utilize Contractor in completing the Project nor shall Surety accept a bid from Contractor for completion of the Project if the CITY, when declaring the Contractor in default, notifies Surety of the City's objection to Contractor's further participation in the completion of the Project.



The Surety, for value received, hereby stipulates and agrees that no change, extension of time, alteration or addition to the terms of the Contract Documents or to the Project to be performed thereunder shall in any way affect its obligations on this bond, and it does hereby waive notice of any such change, extension of time, alteration or addition to the terms of the Contract Documents or to the Project.

[Remainder of Page Left Intentionally Blank.]



IN WITNESS WHEREOF, we have hereunto set our hands and seals this _____ day
of _____, 20__.

CONTRACTOR/PRINCIPAL

Name

By _____

SURETY:

By: _____

Attorney-In-Fact

The rate of premium on this bond is _____ per thousand. The total amount of
premium charges, \$ _____.
(The above must be filled in by corporate attorney.)

THIS IS A REQUIRED FORM

Any claims under this bond may be addressed to:

(Name and Address of Surety) _____

(Name and Address of Agent or
Representative for service of
process in California, if different
from above) _____

(Telephone number of Surety and
Agent or Representative for service
of process in California) _____



STATE OF CALIFORNIA)
) ss.
CITY OF _____)

On this _____ day of _____, in the year 20__, before me, _____, a Notary Public in and for said state, personally appeared _____, known to me to be the person whose name is subscribed to the within instrument as the Attorney-In-Fact of the (Surety) acknowledged to me that he subscribed the name of the _____ (Surety) thereto and his own name as Attorney-In-Fact.

Notary Public in and for said State

(SEAL)

Commission expires: _____

NOTE: A copy of the Power-of-Attorney to local representatives of the bonding company must be attached hereto.



PAYMENT BOND

KNOW ALL MEN BY THESE PRESENTS That

WHEREAS, the City of Beaumont (hereinafter designated as the "City"), by action taken or a resolution passed _____, 20__ has awarded to _____ hereinafter designated as the "Principal," a contract for the work described as follows:

_____ (the "Project"); and

WHEREAS, said Principal is required to furnish a bond in connection with said contract; providing that if said Principal or any of its Subcontractors shall fail to pay for any materials, provisions, provender, equipment, or other supplies used in, upon, for or about the performance of the work contracted to be done, or for any work or labor done thereon of any kind, or for amounts due under the Unemployment Insurance Code or for any amounts required to be deducted, withheld, and paid over to the Employment Development Department from the wages of employees of said Principal and its Subcontractors with respect to such work or labor the Surety on this bond will pay for the same to the extent hereinafter set forth.

NOW THEREFORE, we, the Principal and _____ as Surety, are held and firmly bound unto the City in the penal sum of _____ Dollars (\$_____) lawful money of the United States of America, for the payment of which sum well and truly to be made, we bind ourselves, our heirs, executors, administrators, successors and assigns, jointly and severally, firmly by these presents.

THE CONDITION OF THIS OBLIGATION IS SUCH that if said Principal, his or its subcontractors, heirs, executors, administrators, successors or assigns, shall fail to pay any of the persons named in Section 3181 of the Civil Code, fail to pay for any materials, provisions or other supplies, used in, upon, for or about the performance of the work contracted to be done, or for any work or labor thereon of any kind, or amounts due under the Unemployment Insurance Code with respect to work or labor performed under the contract, or for any amounts required to be deducted, withheld, and paid over to the Employment Development Department or Franchise Tax Board from the wages of employees of the contractor and his subcontractors pursuant to Section 18663 of the Revenue and Taxation Code, with respect to such work and labor the Surety or Sureties will pay for the same, in an amount not exceeding the sum herein above specified, and also, in case suit is brought upon this bond, all litigation expenses incurred by the City in such suit, including reasonable attorneys' fees, court costs, expert witness fees and investigation expenses.

This bond shall inure to the benefit of any of the persons named in Section 3181 of the Civil Code so as to give a right of action to such persons or their assigns in any suit brought upon this bond.



It is further stipulated and agreed that the Surety on this bond shall not be exonerated or released from the obligation of this bond by any change, extension of time for performance, addition, alteration or modification in, to, or of any contract, plans, specifications, or agreement pertaining or relating to any scheme or work of improvement herein above described, or pertaining or relating to the furnishing of labor, materials, or equipment therefore, nor by any change or modification of any terms of payment or extension of the time for any payment pertaining or relating to any scheme or work of improvement herein above described, nor by any rescission or attempted rescission or attempted rescission of the contract, agreement or bond, nor by any conditions precedent or subsequent in the bond attempting to limit the right of recovery of claimants otherwise entitled to recover under any such contract or agreement or under the bond, nor by any fraud practiced by any person other than the claimant seeking to recover on the bond and that this bond be construed most strongly against the Surety and in favor of all persons for whose benefit such bond is given, and under no circumstances shall Surety be released from liability to those for whose benefit such bond has been given, by reason of any breach of contract between the owner or City and original contractor or on the part of any obligee named in such bond, but the sole conditions of recovery shall be that claimant is a person described in Section 3110 or 3112 of the Civil Code, and has not been paid the full amount of his claim and that Surety does hereby waive notice of any such change, extension of time, addition, alteration or modification herein mentioned.

IN WITNESS WHEREOF, two (2) identical counterparts of this instrument, each of which shall for all purposes be deemed unoriginal thereof, have been duly executed by the Principal and Surety above named, on the _____ day of _____ 20____ the name and corporate seal of each corporate party being hereto affixed and these presents duly signed by its undersigned representative pursuant to authority of its governing body.

(Corporate Seal of Principal,
if corporation)

Principal (Property Name of Contractor)

By _____
(Signature of Contractor)

(Seal of Surety)

Surety

By _____
Attorney in Fact

(Attached Attorney-In-Fact Certificate and Required Acknowledgements)

*Note: Appropriate Notarial Acknowledgments of Execution by Contractor and +surety and a power of Attorney MUST BE ATTACHED.



02 GENERAL CONDITIONS

CITYWIDE SIDEWALK IMPROVEMENTS CIP R-24



GENERAL CONDITIONS

TABLE OF CONTENTS

GC01.	DEFINITIONS	1
GC02.	CONTRACT DOCUMENTS	2
GC03.	CONTRACTS DOCUMENTS: COPIES & MAINTENANCE	3
GC04.	DETAIL DRAWINGS AND INSTRUCTIONS	3
GC05.	EXISTENCE OF UTILITIES AT THE WORK SITE	4
GC06.	SCHEDULE	5
GC07.	SUBSTITUTIONS	6
GC08.	SHOP DRAWINGS	7
GC09.	SUBMITTALS	7
GC10.	MATERIALS	8
GC11.	CONTRACTOR'S SUPERVISION	8
GC12.	WORKERS	8
GC13.	SUBCONTRACTORS	9
GC14.	PERMITS AND LICENSES	9
GC15.	UTILITY USAGE	9
GC16.	INSPECTION FEES FOR PERMANENT UTILITIES	10
GC17.	TRENCHES	10
GC18.	DIVERSION OF RECYCLABLE WASTE MATERIALS	11
GC19.	REMOVAL OF HAZARDOUS MATERIALS	11
GC20.	SANITARY FACILITIES	12
GC21.	AIR POLLUTION CONTROL	12
GC22.	COMPLIANCE WITH STATE STORM WATER PERMIT	12
GC23.	CLEANING UP	13
GC24.	LAYOUT AND FIELD ENGINEERING	13
GC25.	EXCESSIVE NOISE	14
GC26.	TESTS AND INSPECTIONS	14
GC27.	PROTECTION OF WORK AND PROPERTY	15
GC28.	CONTRACTORS MEANS AND METHODS	17
GC29.	INSPECTOR'S FIELD OFFICE	17
GC30.	AUTHORIZED REPRESENTATIVES	17
GC31.	HOURS OF WORK	17
GC32.	PAYROLL RECORDS	18
GC33.	PREVAILING RATES OF WAGES	19
GC34.	EMPLOYMENT OF APPRENTICES	19
GC35.	NONDISCRIMINATION/EQUAL EMPLOYMENT OPPORTUNITY	20
GC36.	LABOR/EMPLOYMENT SAFETY	20
GC37.	WORKERS' COMPENSATION INSURANCE	20
GC38.	EMPLOYER'S LIABILITY INSURANCE	20
GC39.	COMMERCIAL GENERAL LIABILITY INSURANCE	21
GC40.	AUTOMOBILE LIABILITY INSURANCE	22
GC41.	BUILDER'S RISK ["ALL RISK"]	22
GC42.	FORM AND PROOF OF CARRIAGE OF INSURANCE	22
GC43.	TIME FOR COMPLETION AND LIQUIDATED DAMAGES	24
GC44.	COST BREAKDOWN AND PERIODIC ESTIMATES	25

GENERAL CONDITIONS



GC45.	MOBILIZATION	25
GC46.	PAYMENTS	26
GC47.	PAYMENTS WITHHELD AND BACKCHARGES	27
GC48.	CHANGES AND EXTRA WORK	28
GC49.	OCCUPANCY	31
GC50.	INDEMNIFICATION	31
GC51.	RECORD (“AS BUILT”) DRAWINGS	32
GC52.	RESOLUTION OF CONSTRUCTION CLAIMS	32
GC53.	CITY’S RIGHT TO TERMINATE CONTRACT	34
GC54.	WARRANTY AND GUARANTEE	36
GC55.	DOCUMENT RETENTION & EXAMINATION	37
GC56.	SOILS INVESTIGATIONS	37
GC57.	SEPARATE CONTRACTS	38
GC58.	NOTICE AND SERVICE THEREOF	38
GC59.	NOTICE OF THIRD PARTY CLAIMS	38
GC60.	STATE LICENSE BOARD NOTICE	39
GC61.	INTEGRATION	39
GC62.	ASSIGNMENT	39
GC63.	CHANGE IN NAME AND NATURE OF CONTRACTOR’S LEGAL ENTITY	39
GC64.	ASSIGNMENT OF ANTITRUST ACTIONS	39
GC65.	PROHIBITED INTERESTS	40
GC66.	LAWS AND REGULATIONS	40
GC67.	PATENT FEES OR ROYALTIES	40
GC68.	OWNERSHIP OF DRAWING	41
GC69.	NOTICE OF TAXABLE POSSESSORY INTEREST	41

GENERAL CONDITIONS



GC01. DEFINITIONS

- a. Acceptable, Acceptance or words of similar import shall be understood to be the acceptance of the Engineer and/or the City.
- b. Act of God an Act of God is an earthquake of magnitude 3.5 on the Richter scale and tidal waves.
- c. Approval means written authorization by Engineer and/or City.
- d. Contract Documents includes all documents as stated in the Contract.
- e. City and Contractor are those stated in the Contract. The terms City and Owner may be used interchangeably.
- f. Day shall mean calendar day unless otherwise specifically designated.
- g. Engineer shall mean the General Manager, or his or her designee, of the Department of Public Works for the City of Beaumont, acting either directly or through properly authorized agents, such as agents acting within the scope of the particular duties entrusted to them. Also sometimes referred to as the "City's Representative" or "Representative" in the Contract Documents.
- h. Equal, Equivalent, Satisfactory, Directed, Designated, Selected, As Required and similar words shall mean the written approval, selection, satisfaction, direction, or similar action of the Engineer and/or City.
- i. Indicated, Shown, Detailed, Noted, Scheduled or words of similar meaning shall mean that reference is made to the drawings, unless otherwise noted. It shall be understood that the direction, designation, selection, or similar import of the Engineer and/or City is intended, unless stated otherwise.
- j. Install means the complete installation of any item, equipment or material.
- k. Material shall include machinery, equipment, manufactured articles, or construction such as form work, fasteners, etc., and any other classes of material to be furnished in connection with the Contract. All materials shall be new unless specified otherwise.
- l. Perform shall mean that the Contractor, at Contractor's expense, shall take all actions necessary to complete The Work, including furnishing of necessary labor, tools, and equipment, and providing and installing Materials that are indicated, specified, or required to complete such performance.
- m. Project is The Work planned by City as provided in the Contract Documents.



- n. Provide shall include provide complete in place, that is furnish, install, test and make ready for use.
- o. Recyclable Waste Materials shall mean materials removed from the Project site which are required to be diverted to a recycling center rather than an area landfill. Recyclable Waste Materials include asphalt, concrete, brick, concrete block, and rock.
- p. Specifications means that portion of the Contract Documents consisting of the written requirements for materials, equipment, construction systems, standards and workmanship for the work. Except for Sections 1-9 of the Standard Specifications for Public Works Construction (“Greenbook”), 2015 Edition which are specifically excluded from incorporation into these Contract Documents, the Work shall be done in accordance with the Greenbook, including all current supplements, addenda, and revisions thereof. In the case of conflict between the Greenbook and the Contract Documents, the Contract Documents shall prevail.
- q. The Work means the entire improvement planned by the City pursuant to the Contract Documents.
- r. Work means labor, equipment and materials incorporated in, or to be incorporated in the construction covered by the Contract Documents.

GC02. CONTRACT DOCUMENTS

- a. **Contract Documents.** The Contract Documents are complementary, and what is called for by one shall be as binding as if called for by all.
- b. **Interpretations.** The Contract Documents are intended to be fully cooperative and to be complementary. If Contractor observes that any documents are in conflict, the Contractor shall promptly notify the Engineer in writing. In case of conflicts between the Contract Documents, the order of precedence shall be as follows:
 - 1. Change Orders or Work Change Directives
 - 2. Addenda
 - 3. Special Provisions (or Special Conditions)
 - 4. Technical Specifications
 - 5. Plans (Contract Drawings)
 - 6. Contract
 - 7. General Conditions
 - 8. Instructions to Bidders
 - 9. Notice Inviting Bids
 - 10. Contractor’s Bid Forms
 - 11. Greenbook Standard Specifications (Sections 1-9 Excluded)
 - 12. Standard Plans

GENERAL CONDITIONS



13. Reference Documents

With reference to the Drawings, the order of precedence shall be as follows:

1. Figures govern over scaled dimensions
2. Detail drawings govern over general drawings
3. Addenda or Change Order drawings govern over Contract Drawings
4. Contract Drawings govern over Standard Drawings
5. Contract Drawings govern over Shop Drawings

- c. **Conflicts in Contract Documents.** Notwithstanding the orders of precedence established above, in the event of conflicts, the higher standard shall always apply.
- d. **Organization of Contract Documents.** Organization of the Contract Documents into divisions, sections, and articles, and arrangement of drawings shall not control the Contractor in dividing The Work among subcontractors or in establishing the extent of Work to be performed by any trade.

GC03. CONTRACTS DOCUMENTS: COPIES & MAINTENANCE

Contractor will be furnished, free of charge, **five (5)** copies of the Contract Documents. Additional copies may be obtained at cost of reproduction.

Contractor shall maintain a clean, undamaged set of Contract Documents at the Project site.

GC04. DETAIL DRAWINGS AND INSTRUCTIONS

- a. **Examination of Contract Documents.** Before commencing any portion of The Work, Contractor shall again carefully examine all applicable Contract Documents, the Project site and other information given to Contractor as to materials and methods of construction and other Project requirements. Contractor shall immediately notify the Engineer of any potential error, inconsistency, ambiguity, conflict or lack of detail or explanation. If Contractor performs, permits, or causes the performance of any Work which is in error, inconsistent or ambiguous, or not sufficiently detailed or explained, Contractor shall bear any and all resulting costs, including, without limitation, the cost of correction. In no case shall the Contractor or any subcontractor proceed with Work if uncertain as to the applicable requirements.
- b. **Additional Instructions.** After notification of any error, inconsistency, ambiguity, conflict or lack of detail or explanation, the Engineer will provide any required additional instructions, by means of drawings or other written direction, necessary for proper execution of Work.



- c. **Quality of Parts, Construction and Finish.** All parts of The Work shall be of the best quality of their respective kinds and the Contractor must use all diligence to inform itself fully as to the required construction and finish. In no case shall Contractor proceed with The Work without obtaining first from the Engineer such Approval may be necessary for the proper performance of Work.
- d. **Contractor's Variation from Contract Document Requirements.** If it is found that the Contractor has varied from the requirements of the Contract Documents including the requirement to comply with all applicable laws, ordinances, rules and regulations, the Engineer may at any time, before or after completion of the Work, order the improper Work removed, remade or replaced by the Contractor at the Contractor's expense.

GC05. EXISTENCE OF UTILITIES AT THE WORK SITE

- a. The City has endeavored to determine the existence of utilities at the Project site from the records of the owners of known utilities in the vicinity of the Project. The positions of these utilities as derived from such records are shown on the Plans.
- b. **Beaumont Cherry Valley Water District (BCVWD) is planning to replace 12" water main in the 5th Street (from California to Michigan). Contractor shall coordinate with the BCVWD before commencing any work on the 5th Street.**
- c. No excavations were made to verify the locations shown for underground utilities. The service connections to these utilities are not shown on the plans. It shall be the responsibility of the Contractor to determine the exact location of all service connections. The Contractor shall make its own investigations, including exploratory excavations, to determine the locations and type of service connections, prior to commencing Work which could result in damage to such utilities. The Contractor shall immediately notify the City and Engineer in writing of any utility discovered in a different position than shown on the Plans or which is not shown on the Plans.
- d. All water meters, water valves, fire hydrants, electrical utility vaults, telephone vaults, gas utility valves, and other subsurface structures shall be relocated or adjusted to final grade by the Contractor. Locations of existing utilities shown on the Plans are approximate and may not be complete. The Contractor shall be responsible for coordinating its Work with all utility companies during the construction of The Work.
- e. Notwithstanding the above, pursuant to Section 4215 of the Government Code, the City has the responsibility to identify, with reasonable accuracy, main or trunkline facilities on the plans and specifications. In the event that main or trunkline utility facilities are not identified with reasonable accuracy in the plans and specifications made a part of the invitation for bids, City shall assume the responsibility for their timely removal, relocation, or protection.

GENERAL CONDITIONS



- f. Contractor, except in an emergency, shall contact the appropriate regional notification center, Southern California Underground Service Alert at 1-800-227-2600 at least two working days prior to commencing any excavation if the excavation will be performed in an area which is known, or reasonably should be known, to contain subsurface installations other than the underground facilities owned or operated by the City, and obtain an inquiry identification number from that notification center. No excavation shall be commenced or carried out by the Contractor unless such an inquiry identification number has been assigned to the Contractor or any subcontractor of the Contractor and the City has been given the identification number by the Contractor.

GC06. SCHEDULE

- a. **Estimated Schedule.** Within fourteen (14) days after the issuance of the Notice to Proceed, Contractor shall prepare a Project schedule and shall submit this to the Engineer for Approval. The receipt or Approval of any schedules by the Engineer or the City shall not in any way relieve the Contractor of its obligations under the Contract Documents. The Contractor is fully responsible to determine and provide for any and all staffing and resources at levels which allow for good quality and timely completion of the Project. Contractor's failure to incorporate all elements of Work required for the performance of the Contract or any inaccuracy in the schedule shall not excuse the Contractor from performing all Work required for a completed Project within the specified Contract time period. If the required schedule is not received by the time the first payment under the Contract is due, Contractor shall not be paid until the schedule is received, reviewed and accepted by the Engineer.
- b. **Schedule Contents.** The schedule shall allow enough time for inclement weather. The schedule shall indicate the beginning and completion dates of all phases of construction; critical path for all critical, sequential time related activities; and "float time" for all "slack" or "gaps" in the non-critical activities. The schedule shall clearly identify all staffing and other resources which in the Contractor's judgment are needed to complete the Project within the time specified for completion. Schedule duration shall match the Contract time. Schedules indicating early completion will be rejected.
- c. **Schedule Updates.** Contractor shall continuously update its construction schedule. Contractor shall submit an updated and accurate construction schedule to the Engineer whenever requested to do so by Engineer and with each progress payment request. The Engineer may withhold progress payments or other amounts due under the Contract Documents if Contractor fails to submit an updated and accurate construction schedule.



GC07. SUBSTITUTIONS

- a. Pursuant to Public Contract Code Section 3400(b) the City may make a finding that is described in the invitation for bids that designates certain products, things, or services by specific brand or trade name.
- b. Unless specifically designated in the Contract Documents, whenever any material, process, or article is indicated or specified by grade, patent, or proprietary name or by name of manufacturer, such Specifications shall be deemed to be used for the purpose of facilitating the description of the material, process or article desired and shall be deemed to be followed by the words "or equal." Contractor may, unless otherwise stated, offer for substitution any material, process or article which shall be substantially equal or better in every respect to that so indicated or specified in the Contract Documents. However, the City may have adopted certain uniform standards for certain materials, processes and articles.
- c. Contractor shall submit requests, together with substantiating data, for substitution of any "or equal" material, process or article no later than thirty-five (35) days after award of the Contract. To facilitate the construction schedule and sequencing, some requests may need to be submitted before thirty-five (35) days after award of Contract. Provisions regarding submission of "or equal" requests shall not in any way authorize an extension of time for performance of this Contract. If a proposed "or equal" substitution request is rejected, Contractor shall be responsible for providing the specified material, process or article. The burden of proof as to the equality of any material, process or article shall rest with the Contractor. The City has the complete and sole discretion to determine if a material, process or article is an "or equal" material, process or article that may be substituted.
- d. Data required to substantiate requests for substitutions of an "or equal" material, process or article data shall include a signed affidavit from the Contractor stating that, and describing how, the substituted "or equal" material, process or article is equivalent to that specified in every way except as listed on the affidavit. Substantiating data shall include any and all illustrations, specifications, and other relevant data including catalog information which describes the requested substituted "or equal" material, process or article, and substantiates that it is an "or equal" to the material, process or article. The substantiating data must also include information regarding the durability and lifecycle cost of the requested substituted "or equal" material, process or article. Failure to submit all the required substantiating data, including the signed affidavit, to the City in a timely fashion will result in the rejection of the proposed substitution.
- e. The Contractor shall bear all of the City's costs associated with the review of substitution requests.

GENERAL CONDITIONS



- f. The Contractor shall be responsible for all costs related to a substituted “or equal” material, process or article.
- g. Contractor is directed to the Special Conditions (if any) to review any findings made pursuant to Public Contract Code section 3400.

GC08. SHOP DRAWINGS

- a. Contractor shall check and verify all field measurements and shall submit with such promptness as to provide adequate time for review and cause no delay in his own Work or in that of any other contractor, subcontractor, or worker on the Project, six (6) copies of all shop or setting drawings, calculations, schedules, and materials list, and all other provisions required by the Contract. Contractor shall sign all submittals affirming that submittals have been reviewed and approved by Contractor prior to submission to Engineer. Each signed submittal shall affirm that the submittal meets all the requirements of the Contract Documents except as specifically and clearly noted and listed on the cover sheet of the submittal.
- b. Contractor shall make any corrections required by the Engineer, and file with the Engineer six (6) corrected copies each, and furnish such other copies as may be needed for completion of the Work. Engineer’s approval of shop drawings shall not relieve Contractor from responsibility for deviations from the Contract Documents unless Contractor has, in writing, called Engineer’s attention to such deviations at time of submission and has secured the Engineer’s written Approval. Engineer’s Approval of shop drawings shall not relieve Contractor from responsibility for errors in shop drawings.

GC09. SUBMITTALS

- a. Contractor shall furnish to the Engineer for approval, prior to purchasing or commencing any Work, a log of all samples, material lists and certifications, mix designs, schedules, and other submittals, as required in the specifications. The log shall indicate whether samples will be provided in accordance with other provisions of this Contract.
- b. Contractor will provide samples and submittals, together with catalogs and supporting data required by the Engineer, to the Engineer within a reasonable time period to provide for adequate review and avoid delays in the Work.
- c. These requirements shall not authorize any extension of time for performance of this Contract. Engineer will check and approve such samples, but only for conformance with design concept of work and for compliance with information given in the Contract Documents. Work shall be in accordance with approved samples and submittals.



GC10. MATERIALS

- a. Except as otherwise specifically stated in the Contract Documents, Contractor shall provide and pay for all materials, labor, tools, equipment, water, lights, power, transportation, superintendence, temporary constructions of every nature, and all other services and facilities of every nature whatsoever necessary to execute and complete this Contract within specified time.
- b. Unless otherwise specified, all materials shall be new and the best of their respective kinds and grades as noted and/or specified, and workmanship shall be of good quality.
- c. Materials shall be furnished in ample quantities and at such times as to ensure uninterrupted progress of The Work and shall be stored properly and protected as required by the Contract Documents. Contractor shall be entirely responsible for damage or loss by weather or other causes to materials or Work.
- d. No materials, supplies, or equipment for Work under this Contract shall be purchased subject to any chattel mortgage or under a conditional sale or other agreement by which an interest therein or in any part thereof is retained by the seller or supplier. Contractor warrants good title to all material, supplies, and equipment installed or incorporated in the work and agrees upon completion of all work to deliver the Project, to the City free from any claims, liens, or charges.
- e. Materials shall be stored on the Project site in such manner so as not to interfere with any operations of the City or any independent contractor.

GC11. CONTRACTOR'S SUPERVISION

Contractor shall continuously keep at the Project site, a competent and experienced full-time Project superintendent approved by the City. Superintendent must be able to proficiently speak, read and write in English. Contractor shall continuously provide efficient supervision of the Project.

GC12. WORKERS

- a. Contractor shall at all times enforce strict discipline and good order among its employees. Contractor shall not employ on the Project any unfit person or any one not skilled in the Work assigned to him or her.
- b. Any person in the employ of the Contractor whom the City may deem incompetent or unfit shall be dismissed from The Work and shall not be employed on this Project except with the written Approval of the City.



GC13. SUBCONTRACTORS

- a. Contractor agrees to bind every subcontractor to the terms of the Contract Documents as far as such terms are applicable to subcontractor's portion of The Work. Contractor shall be as fully responsible to the City for the acts and omissions of its subcontractors and of persons either directly or indirectly employed by its subcontractors, as Contractor is for acts and omissions of persons directly employed by Contractor. Nothing contained in these Contract Documents shall create any contractual relationship between any subcontractor and the City.
- b. The City reserves the right to Approve all subcontractors. The City's Approval of any subcontractor under this Contract shall not in any way relieve Contractor of its obligations in the Contract Documents.
- c. Prior to substituting any subcontractor listed in the Bid Forms, Contractor must comply with the requirements of the Subletting and Subcontracting Fair Practices Act pursuant to California Public Contract Code section 4100 et seq.

GC14. PERMITS AND LICENSES

Permits and licenses necessary for prosecution of The Work shall be secured and paid for by Contractor, unless otherwise specified in the Contract Documents.

- a. Contractor shall obtain and pay for all other permits and licenses required for The Work, including excavation permit and for plumbing, mechanical and electrical work and for operations in or over public streets or right of way under jurisdiction of public agencies other than the City.
- b. The Contractor shall arrange and pay for all off-site inspection of the Work related to permits and licenses, including certification, required by the specifications, drawings, or by governing authorities, except for such off-site inspections delineated as the City's responsibility pursuant to the Contract Documents.
- c. Before Acceptance of the Project, the Contractor shall submit all licenses, permits, certificates of inspection and required approvals to the City.

GC15. UTILITY USAGE

- a. All temporary utilities, including but not limited to electricity, water, gas, and telephone, used on the Work shall be furnished and paid for by Contractor. Contractor shall Provide necessary temporary distribution systems, including meters, if necessary, from distribution points to points on The Work where the utility is needed. Upon completion of The Work, Contractor shall remove all temporary distribution systems.



- b. Contractor shall provide necessary and adequate utilities and pay all costs for water, electricity, gas, oil, and sewer charges required for completion of the Project.
- c. All permanent meters Installed shall be listed in the Contractor's name until Project Acceptance.
- d. If the Contract is for construction in existing facilities, Contractor may, with prior written Approval of the City, use the City's existing utilities by compensating the City for utilities used by Contractor.

GC16. INSPECTION FEES FOR PERMANENT UTILITIES

All inspection fees and other municipal charges for permanent utilities including, but not limited to, sewer, electrical, phone, gas, water, and irrigation shall be paid for by the City. Contractor shall be responsible for arranging the payment of such fees, but inspection fees and other municipal fees relating to permanent utilities shall be paid by the City. Contractor may either request reimbursement from the City for such fees, or shall be responsible for arranging and coordination with City for the payment of such fees.

GC17. TRENCHES

- a. Trenches Five Feet or More in Depth. The Contractor shall submit to the City, in advance of excavation, a detailed plan showing the design of shoring, bracing, sloping or other provisions to be made for worker protection from the hazard of caving ground during the excavation of any trench or trenches five feet or more in depth. If the plan varies from shoring system standards, the plan shall be prepared by a registered civil or structural engineer. The plan shall not be less effective than the shoring, bracing, sloping, or other provisions of the Construction Safety Orders, as defined in the California Code of Regulations.
- b. Excavations Deeper than Four Feet. If work under this Contract involves digging trenches or other excavation that extends deeper than four feet below the surface, Contractor shall promptly, and before the following conditions are disturbed, notify the City, in writing, of any:
 - 1) Material that the Contractor believes may be material that is hazardous waste, as defined in Section 25117 of the Health and Safety Code, that is required to be removed to a Class I, Class II, or Class III disposal site in accordance with provisions of existing law.
 - 2) Subsurface or latent physical conditions at the site differing from those indicated.



- 3) Unknown physical conditions at the site of any unusual nature, different materially from those ordinarily encountered and generally recognized as inherent in work of the character provided for in the Contract.

The City shall promptly investigate the conditions, and if it finds that the conditions do so materially differ, or do involve hazardous waste, and cause a decrease or increase in Contractor's cost of, or the time required for, performance of any part of The Work, shall issue a change order under the procedures described in the Contract Documents.

In the event that a dispute arises between the City and the Contractor as to whether the conditions materially differ, or involve hazardous waste, or cause a decrease or increase in the Contractor's cost of, or time required for, performance of any part of The Work, the Contractor shall not be excused from any scheduled completion date provided for by the Contract, but shall proceed with all Work to be performed under the Contract. Contractor shall retain any and all rights provided either by contract or by law which pertain to the resolution of disputes and protests between the parties.

- c. Groundwater and Dewatering. The Contractor is responsible for all necessary trench and excavation dewatering operations. No additional compensation will be provided should groundwater levels be encountered that are different than those described in the plans and specifications. Discharge of all water must comply with the State Water Resources Control Board's NPDES permit requirements, as described in these specifications.

GC18. DIVERSION OF RECYCLABLE WASTE MATERIALS

In compliance with the applicable City's waste reduction and recycling efforts, Contractor shall divert all Recyclable Waste Materials to appropriate recycling centers. Contractor will be required to submit weight tickets and written proof of diversion with its monthly progress payment requests. Contractor shall complete and execute any certification forms required by City or other applicable agencies to document Contractor's compliance with these diversion requirements. All costs incurred for these waste diversion efforts shall be the responsibility of the Contractor.

GC19. REMOVAL OF HAZARDOUS MATERIALS

Should Contractor encounter material reasonably believed to be polychlorinated biphenyl (PCB) or other toxic wastes and hazardous materials which have not been rendered harmless at the Project site, the Contractor shall immediately stop work at the affected Project site and shall report the condition to the City in writing. The City shall contract for any services required to directly remove and/or abate PCBs and other toxic wastes and hazardous materials, if required by the Project site(s), and shall not require the Contractor to subcontract for such services. The Work in the affected area shall not thereafter be resumed except by written agreement of the City and Contractor.

GENERAL CONDITIONS



GC20. SANITARY FACILITIES

Contractor shall provide sanitary temporary toilet buildings for the use of all workers. All toilets shall comply with local codes and ordinances. Toilets shall be kept supplied with toilet paper and shall have workable door fasteners. Toilets shall be serviced no less than once weekly and shall be present in a quantity of not less than 1 per 20 workers as required by CAL-OSHA regulation. The toilets shall be maintained in a sanitary condition at all times. Use of toilet facilities in The Work under construction shall not be permitted. Any other Sanitary Facilities required by CAL-OSHA shall be the responsibility of the Contractor.

GC21. AIR POLLUTION CONTROL

Contractor shall comply with all air pollution control rules, regulations, ordinances and statutes. All containers of paint, thinner, curing compound, solvent or liquid asphalt shall be labeled to indicate that the contents fully comply with the applicable material requirements.

GC22. COMPLIANCE WITH STATE STORM WATER PERMIT

- a. Contractor shall be required to comply with all conditions of the State Water Resources Control Board (“State Water Board”) National Pollutant Discharge Elimination System General Permit for Waste Discharge Requirements for Discharges of Storm Water Runoff Associated with Construction Activity (“Permit”) for all construction activity which results in the disturbance of in excess of one acre of total land area or which is part of a larger common area of development or sale. Contractor shall be responsible for filing the Notice of Intent and for obtaining the Permit. Contractor shall be solely responsible for preparing and implementing a Storm Water Pollution Prevention Plan (“SWPPP”) prior to initiating Work. In bidding on this Contract, it shall be Contractor’s responsibility to evaluate the cost of procuring the Permit and preparing the SWPPP as well as complying with the SWPPP and any necessary revision to the SWPPP. Contractor shall comply with all requirements of the State Water Resources Control Board. Contractor shall include all costs of compliance with specified requirements in the Contract amount.
- b. Contractor shall be responsible for procuring, implementing and complying with the provisions of the Permit and the SWPPP, including the standard provisions, monitoring and reporting requirements as required by the Permit. Contractor shall provide copies of all reports and monitoring information to the Engineer.
- c. Contractor shall comply with the lawful requirements of any applicable municipality, the City, drainage district, and other local agencies regarding discharges of storm water to separate storm drain system or other watercourses under their jurisdiction, including applicable requirements in municipal storm water management programs.

GENERAL CONDITIONS



- d. Storm, surface, nuisance, or other waters may be encountered at various times during construction of The Work. Therefore, the Contractor, by submitting a Bid, hereby acknowledges that it has investigated the risk arising from such waters, has prepared its Bid accordingly, and assumes any and all risks and liabilities arising therefrom.
- e. Failure to comply with the Permit is in violation of federal and state law. Contractor hereby agrees to indemnify and hold harmless City, its officials, officers, agents, employees and authorized volunteers from and against any and all claims, demands, losses or liabilities of any kind or nature which City, its officials, officers, agents, employees and authorized volunteers may sustain or incur for noncompliance with the Permit arising out of or in connection with the Project, except for liability resulting from the sole established negligence, willful misconduct or active negligence of the City, its officials, officers, agents, employees or authorized volunteers. City may seek damages from Contractor for delay in completing the Contract in accordance with the Contract Documents, caused by Contractor's failure to comply with the Permit.

GC23. CLEANING UP

- a. Contractor at all times shall keep premises free from debris such as waste, rubbish, and excess materials and equipment. Contractor shall not store debris under, in, or about the premises. Upon completion of Work, Contractor shall clean the interior and exterior of the building or improvement including fixtures, equipment, walls, floors, ceilings, roofs, window sills and ledges, horizontal projections, and any areas where debris has collected so surfaces are free from foreign material or discoloration. Contractor shall clean and polish all glass, plumbing fixtures, and finish hardware and similar finish surfaces and equipment and contractor shall also remove temporary fencing, barricades, planking and construction toilet and similar temporary facilities from site. Contractor shall also clean all buildings, asphalt and concrete areas to the degree necessary to remove oil, grease, fuel, or other stains caused by Contractor operations or equipment.
- b. Contractor shall fully clean up the site at the completion of The Work. If the Contractor fails to immediately clean up at the completion of The Work, the City may do so and the cost of such clean up shall be charged back to the Contractor.

GC24. LAYOUT AND FIELD ENGINEERING

All field engineering required for laying out The Work and establishing grades for earthwork operations shall be furnished by the Contractor at its expense. Layout shall be done by a registered civil engineer Approved by the Engineer. Any required "as-built" drawings of the Work shall be prepared by the registered civil engineer.



GC25. EXCESSIVE NOISE

- a. The Contractor shall use only such equipment on the work and in such state of repair so that the emission of sound therefrom is within the noise tolerance level of that equipment as established by CAL-OSHA.
- b. The Contractor shall comply with the most restrictive of the following: (1) local sound control and noise level rules, regulations and ordinances and (2) the requirements contained in these Contract Documents, including hours of operation requirements. No internal combustion engine shall be operated on the Project without a muffler of the type recommended by the manufacturer. Should any muffler or other control device sustain damage or be determined to be ineffective or defective, the Contractor shall promptly remove the equipment and shall not return said equipment to the job until the device is repaired or replaced. Said noise and vibration level requirements shall apply to all equipment on the job or related to the job, including but not limited to, trucks, transit mixers or transit equipment that may or may not be owned by the Contractor.

GC26. TESTS AND INSPECTIONS

- a. If the Contract Documents, the Engineer, or any instructions, laws, ordinances, or public authority require any part of The Work to be tested or Approved, Contractor shall provide the Engineer at least two (2) working days notice of its readiness for observation or inspection. If inspection is by a public authority other than the City, Contractor shall promptly inform the City of the date fixed for such inspection. Required certificates of inspection (or similar) shall be secured by Contractor. Costs for City testing and City inspection shall be paid by the City. Costs of tests for Work found not to be in compliance shall be paid by the Contractor.
- b. If any Work is done or covered up without the required testing or approval, the Contractor shall uncover or deconstruct the Work, and the Work shall be redone after completion of the testing at the Contractor's cost in compliance with the Contract Documents.
- c. Where inspection and testing are to be conducted by an independent laboratory or agency, materials or samples of materials to be inspected or tested shall be selected by such laboratory or agency, or by the City, and not by Contractor. All tests or inspections of materials shall be made in accordance with the commonly recognized standards of national organizations.
- d. In advance of manufacture of materials to be supplied by Contractor which must be tested or inspected, Contractor shall notify the City so that the City may arrange for testing at the source of supply. Any materials which have not satisfactorily passed such testing and inspection shall not be incorporated into The Work.

GENERAL CONDITIONS



- e. If the manufacture of materials to be inspected or tested will occur in a plant or location outside the geographic limits of City, the Contractor shall pay for any excessive or unusual costs associated with such testing or inspection, including but not limited to excessive travel time, standby time and required lodging.
- f. Reexamination of Work may be ordered by the City. If so ordered, Work must be uncovered or deconstructed by Contractor. If Work is found to be in accordance with the Contract Documents, the City shall pay the costs of reexamination and reconstruction. If such work is found not to be in accordance with the Contract Documents, Contractor shall pay all costs.

GC27. PROTECTION OF WORK AND PROPERTY

- a. The Contractor shall be responsible for all damages to persons or property that occur as a result of The Work. Contractor shall be responsible for the proper care and protection of all materials delivered and Work performed until completion and final Acceptance by the City. All Work shall be solely at the Contractor's risk. Contractor shall adequately protect adjacent property from settlement or loss of lateral support as necessary. Contractor shall comply with all applicable safety laws and building codes to prevent accidents or injury to persons on, about, or adjacent to the Project site where Work is being performed. Contractor shall erect and properly maintain at all times, as required by field conditions and progress of work, all necessary safeguards, signs, barriers, lights, and watchmen for protection of workers and the public, and shall post danger signs warning against hazards created in the course of construction.
- b. In an emergency affecting safety of life or of work or of adjoining property, Contractor, without special instruction or authorization from the Engineer, is hereby permitted to act to prevent such threatened loss or injury; and Contractor shall so act, without appeal, if so authorized or instructed by the Engineer or the City. Any compensation claimed by Contractor on account of emergency work shall be determined by and agreed upon by the City and the Contractor.
- c. Contractor shall provide such heat, covering, and enclosures as are necessary to protect all Work, materials, equipment, appliances, and tools against damage by weather conditions.
- d. Contractor shall take adequate precautions to protect existing sidewalks, curbs, pavements, utilities, and other adjoining property and structures, and to avoid damage thereto, and Contractor shall repair any damage thereto caused by The Work operations. Contractor shall:
 - 1) Enclose the working area with a substantial barricade, and arrange work to cause minimum amount of inconvenience and danger to the public.



- 2) Provide substantial barricades around any shrubs or trees indicated to be preserved.
- 3) Deliver materials to the Project site over a route designated by the Engineer.
- 4) Provide any and all dust control required and follow the Applicable air quality regulations as appropriate. If the Contractor does not comply, the City shall have the immediate authority to provide dust control and deduct the cost from payments to the Contractor.
- 5) Confine Contractor's apparatus, the storage of materials, and the operations of its workers to limits required by law, ordinances, permits, or directions of the Engineer. Contractor shall not unreasonably encumber the Project site with its materials.
- 6) Take care to prevent disturbing or covering any survey markers, monuments, or other devices marking property boundaries or corners. If such markers are disturbed by accident, they shall be replaced by an approved civil engineer or land surveyor, at no cost to the City.
- 7) Ensure that existing facilities, fences and other structures are all adequately protected and that, upon completion of all Work, all facilities that may have been damaged are restored to a condition acceptable to the City.
- 8) Preserve and protect from injury all buildings, pole lines and all direction, warning and mileage signs that have been placed within the right-of-way.
- 9) At the completion of work each day, leave the Project site in a clean, safe condition.
- 10) Comply with any stage construction and traffic handling plans. Access to residences and businesses shall be maintained at all times.

These precautionary measures will apply continuously and not be limited to normal working hours. Full compensation for the Work involved in the preservation of life, safety and property as above specified shall be considered as included in the prices paid for the various contract items of Work, and no additional allowance will be made therefor.

- e. Should damage to persons or property occur as a result of The Work, Contractor shall be responsible for proper investigation, documentation, including video or photography, to adequately memorialize and make a record of what transpired. The City shall be entitled to inspect and copy any such documentation, video, or photographs.

GENERAL CONDITIONS



GC28. CONTRACTORS MEANS AND METHODS

Contractor is solely responsible for the means and methods utilized to Perform The Work. In no case shall the Contractor's means and methods deviate from commonly used industry standards.

GC29. INSPECTOR'S FIELD OFFICE

- a. The Contractor shall be responsible for providing the inspector's field office. The Office shall be a substantial waterproof construction with adequate natural light and ventilation by means of stock design windows. Door shall have a key type lock or padlock clasp. The office shall have heating and air conditioning and shall be equipped with a telephone, a telephone answering machine, and a fax machine at Contractor's expense.
- b. A table satisfactory for the study of plans and two chairs shall be Provided by Contractor. Contractor shall Provide and pay for adequate electric lights, local telephone service, and adequate heat and air conditioning for the field office until authorized removal.

GC30. AUTHORIZED REPRESENTATIVES

The City shall designate representatives, who shall have the right to be present at the Project site at all times. The City may designate an inspector who shall have the right to observe all of the Contractor's Work. The inspector is not authorized to make changes in the Contract Documents. The inspector shall not be responsible for the Contractor's failure to carry out The Work in accordance with the Contract Documents. Contractor shall provide safe and proper facilities for such access.

GC31. HOURS OF WORK

- a. Eight (8) hours of work shall constitute a legal day's work. The Contractor and each subcontractor shall forfeit, as penalty to the City, twenty-five dollars (\$25) for each worker employed in the execution of Work by the Contractor or any subcontractor for each day during which such worker is required or permitted to work more than eight (8) hours in any one day and forty (40) hours in any week in violation of the provisions of the Labor Code, and in particular, Section 1810 to Section 1815, except as provided in Labor Code Section 1815.
- b. Work shall be accomplished on a regularly scheduled eight (8) hour per day work shift basis, Monday through Friday, between the hours of 7:00 a.m. and 5:00 p.m.
- c. It shall be unlawful for any person to operate, permit, use, or cause to operate any of the following at the Project site, other than between the hours of 7:00 a.m. to 5:00 p.m., Monday through Friday, with no Work allowed on City-observed holidays, unless otherwise Approved by the Engineer:

GENERAL CONDITIONS



- 1) Powered Vehicles
- 2) Construction Equipment
- 3) Loading and Unloading Vehicles
- 4) Domestic Power Tool.

GC32. PAYROLL RECORDS

- a. Pursuant to Labor Code Section 1776, the Contractor and each subcontractor shall maintain weekly certified payroll records showing the name, address, social security number, work classification, straight time and overtime hours paid each day and week, and the actual per diem wages paid to each journeyman, apprentice, worker or other employee employed in connection with the work. Contractor shall certify under penalty of perjury that records maintained and submitted by Contractor are true and accurate. Contractor shall also require subcontractor(s) to certify weekly payroll records under penalty of perjury.
- b. The payroll records described herein shall be certified and submitted by the Contractor at a time designated by the City. The Contractor shall also provide the following:
 - 1) A certified copy of the employee's payroll records shall be made available for inspection or furnished to such employee or his or her authorized representative on request.
 - 2) A certified copy of all payroll records described herein shall be made available for inspection or furnished upon request of the Department of Industrial Relations ("DIR").
- c. The certified payroll records shall be on forms provided by the Division of Labor Standards Enforcement ("DLSE") of the DIR or shall contain the same information as the forms provided by the DLSE.
- d. Any copy of records made available for inspection and furnished upon request to the public shall be marked or obliterated in such a manner as to prevent disclosure of an individual's name, address, and social security number. The name and address of the Contractor or any subcontractor shall not be marked or obliterated.
- e. In the event of noncompliance with the requirements of this Section, the Contractor shall have ten (10) days in which to comply subsequent to receipt of written notice specifying any item or actions necessary to ensure compliance with this section. Should noncompliance still be evident after such ten (10) day period, the Contractor shall, as a penalty to the City, forfeit Twenty-five Dollars (\$25.00) for each day, or portion thereof, for each worker until strict compliance is



effectuated. Upon the request of the DIR, such penalties shall be withheld from contract payments.

GC33. PREVAILING RATES OF WAGES

- a. The Contractor is aware of the requirements of Labor Code Sections 1720 et seq. and 1770 et seq., as well as California Code of Regulations, Title 8, Section 16000 et seq. (“Prevailing Wage Laws”), which require the payment of prevailing wage rates and the performance of other requirements on certain “public works” and “maintenance” projects. Since this Project involves an applicable “public works” or “maintenance” project, as defined by the Prevailing Wage Laws, and since the total compensation is \$1,000 or more, Contractor agrees to fully comply with such Prevailing Wage Laws. The Contractor shall obtain a copy of the prevailing rates of per diem wages at the commencement of this Agreement from the website of the Division of Labor Statistics and Research of the Department of Industrial Relations located at www.dir.ca.gov/dlsr/. In the alternative, the Contractor may view a copy of the prevailing rates of per diem wages at the City. Contractor shall make copies of the prevailing rates of per diem wages for each craft, classification or type of worker needed to perform work on the Project available to interested parties upon request, and shall post copies at the Contractor’s principal place of business and at the Project site. Contractor shall defend, indemnify and hold the City, its elected officials, officers, employees and agents free and harmless from any claims, liabilities, costs, penalties or interest arising out of any failure or alleged failure to comply with the Prevailing Wage Laws.
- b. The Contractor and each subcontractor shall forfeit as a penalty to the City not more than fifty dollars (\$50) for each calendar day, or portion thereof, for each worker paid less than the stipulated prevailing wage rate for any work done by him, or by any subcontract under him, in violation of the provisions of the Labor Code. The difference between such stipulated prevailing wage rate and the amount paid to each worker for each calendar day or portion thereof for which each worker was paid less than the stipulated prevailing wage rate shall be paid to each worker by the Contractor.
- c. Contractor shall post, at appropriate conspicuous points on the Project site, a schedule showing all determined general prevailing wage rates and all authorized deductions, if any, from unpaid wages actually earned.
- d. If the Work involves federal funds or otherwise requires compliance with the Davis-Bacon Fair Labor Standards Act, the Contractor and all its subcontractors shall comply with the higher of the state or federal prevailing wage rates.

GC34. EMPLOYMENT OF APPRENTICES

The Contractor’s attention is directed to the provisions of Sections 1777.5, 1777.6, and 1777.7 of the Labor Code concerning employment of apprentices by the Contractor or

GENERAL CONDITIONS



any subcontractor. The Contractor shall obtain a certificate of apprenticeship before employing any apprentice pursuant to Section 1777.5, 1777.6, and 1777.7 of the Labor Code. Information relative to apprenticeship standards, wage schedules, and other requirements may be obtained from the Director of Industrial Relations, the Administrator of Apprenticeships, San Francisco, California, or from the Division of Apprenticeship Standards and its branch offices.

GC35. NONDISCRIMINATION/EQUAL EMPLOYMENT OPPORTUNITY

Pursuant to Labor Code Section 1735 and other applicable provisions of law, the Contractor and its subcontractors shall not discriminate against any employee or applicant for employment because of race, color, religion, sex, national origin, age, political affiliation, marital status, or handicap on this Project. The Contractor will take affirmative action to insure that employees are treated during employment or training without regard to their race, color, religion, sex, national origin, age, political affiliation, marital status, or handicap.

GC36. LABOR/EMPLOYMENT SAFETY

The Contractor shall maintain emergency first aid treatment for his employees which complies with the Federal Occupational Safety and Health Act of 1970 (29 U.S.C. § 651 et seq.), and California Code of Regulations, Title 8, Industrial Relations Division 1, Department of Industrial Relations, Chapter 4.

GC37. WORKERS' COMPENSATION INSURANCE

The Contractor shall Provide, during the life of this Contract, workers' compensation insurance for all of the employees engaged in Work under this Contract, on or at the Project site, and, in case any of sublet Work, the Contractor shall require the subcontractor similarly to provide workers' compensation insurance for all the latter's employees as prescribed by State law. Any class of employee or employees not covered by a subcontractor's insurance shall be covered by the Contractor's insurance. In case any class of employees engaged in work under this Contract, on or at the Project site, is not protected under the Workers' Compensation Statutes, the Contractor shall provide or shall cause a subcontractor to provide, adequate insurance coverage for the protection of such employees not otherwise protected. The Contractor is required to secure payment of compensation to his employees in accordance with the provisions of Section 3700 of the Labor Code. The Contractor shall file with the City certificates of his insurance protecting workers. Company or companies providing insurance coverage shall be acceptable to the City, if in the form and coverage as set forth in the Contract Documents.

GC38. EMPLOYER'S LIABILITY INSURANCE

Contractor shall provide during the life of this Contract, Employer's Liability Insurance, including Occupational Disease, in the amount of, at least, one million dollars

GENERAL CONDITIONS



(\$1,000,000.00) per person per accident. Contractor shall provide City with a certificate of Employer's Liability Insurance. Such insurance shall comply with the provisions of the Contract Documents. The policy shall be endorsed, if applicable, to provide a Borrowed Servant/Alternate Employer Endorsement and contain a Waiver of Subrogation in favor of the City.

GC39. COMMERCIAL GENERAL LIABILITY INSURANCE

- a. Contractor shall procure and maintain during the life of this Contract and for such other period as may be required herein, at its sole expense, Commercial General Liability insurance coverage, including but not limited to, premises liability, contractual liability, products/completed operations if applicable, personal and advertising injury – which may arise from or out of Contractor's operations, use, and management of the Project site, or the performance of its obligations hereunder. Policy limits shall not be less than **\$2,000,000** per occurrence for bodily injury, personal injury and property damage. If Commercial General Liability Insurance or other form with a general aggregate limit is used, either the general aggregate limit shall apply separately to this project/location or the general aggregate limit shall be twice the required occurrence limit.
- b. Such policy shall comply with all the requirements of this Article. The limits set forth herein shall apply separately to each insured against whom claims are made or suits are brought, except with respect to the limits of liability. Further the limits set forth herein shall not be construed to relieve the Contractor from liability in excess of such coverage, nor shall it limit Contractor's indemnification obligations to the City, and shall not preclude the City from taking such other actions available to the City under other provisions of the Contract Documents or law.
- c. Contractor shall make certain that any and all subcontractors hired by Contractor are insured in accordance with this Contract. If any subcontractor's coverage does not comply with the foregoing provisions, Contractor shall indemnify and hold the City harmless from any damage, loss, cost, or expense, including attorneys' fees, incurred by the City as a result thereof.
- d. All general liability policies provided pursuant to the provisions of this Article shall comply with the provisions of the Contract Documents.
- e. All general liability policies shall be written to apply to all bodily injury, including death, property damage, personal injury, owned and non-owned equipment, blanket contractual liability, completed operations liability, explosion, collapse, under-ground excavation, removal of lateral support, and other covered loss, however occasioned, occurring during the policy term, and shall specifically insure the performance by Contractor of that part of the indemnification contained in these General Conditions, relating to liability for injury to or death of persons and damage to property. If the coverage contains one or more aggregate limits, a



minimum of 50% of any such aggregate limit must remain available at all times; if over 50% of any aggregate limit has been paid or reserved, the City may require additional coverage to be purchased by Contractor to restore the required limits. Contractor may combine primary, umbrella, and as broad as possible excess liability coverage to achieve the total limits indicated above. Any umbrella or excess liability policy shall include the additional insured endorsement described in the Contract Documents.

GC40. AUTOMOBILE LIABILITY INSURANCE

Contractor shall take out and maintain at all times during the term of this Contract Automobile Liability Insurance in the amount of, at least, one million dollars (\$1,000,000). Such insurance shall provide coverage for bodily injury and property damage including coverage for non-owned and hired vehicles, in a form and with insurance companies acceptable to the City. Such insurance shall comply with the provisions of Article 30 below.

GC41. BUILDER'S RISK ["ALL RISK"]

- a. It is the Contractor's responsibility to maintain or cause to be maintained Builder's Risk ["All Risk"] extended coverage insurance on all work, material, equipment, appliances, tools, and structures which are a part of the Contract and subject to loss or damage by fire, and vandalism and malicious mischief, in an amount to cover 100% of the replacement cost. The City accepts no responsibility until the Contract is formally accepted by the Governing Board for the work. The Contractor is required to file with the City a certificate evidencing fire insurance coverage.
- b. Provide insurance coverage on completed value form, all-risk or special causes of loss coverage.
 - 1) Insurance policies shall be so conditioned as to cover the performance of any extra work performed under the Contract.
 - 2) Coverage shall include all materials stored on site and in transit.
 - 3) Coverage shall include Contractor's tools and equipment.
 - 4) Insurance shall include boiler, machinery and material hoist coverage.
- c. Such insurance shall comply with the provisions of the Contract Documents.

GC42. FORM AND PROOF OF CARRIAGE OF INSURANCE

- a. Any insurance carrier providing insurance coverage required by the Contract Documents shall be admitted to and authorized to do business in the State of



- California unless waived, in writing, by the City Risk Manager. Carrier(s) shall have an A.M. Best rating of not less than an A:VIII. Insurance deductibles or self-insured retentions must be declared by the Contractor, and such deductibles and retentions shall have the prior written consent from the City. At the election of the City the Contractor shall either 1) reduce or eliminate such deductibles or self-insured retentions, or 2) procure a bond which guarantees payment of losses and related investigations, claims administration, and defense costs and expenses.
- b. Contractor shall cause its insurance carrier(s) to furnish the City with either 1) a properly executed original Certificate(s) of Insurance and certified original copies of Endorsements effecting coverage as required herein, or 2) if requested to do so in writing by the City Risk Manager, provide original Certified copies of policies including all Endorsements and all attachments thereto, showing such insurance is in full force and effect. The City, its Director's and officers, employees, agents or representatives are named as Additional Insureds and Provide a Waiver of Subrogation in favor of those parties. Further, said Certificate(s) and policies of insurance shall contain the covenant of the insurance carrier(s) that shall provide no less than thirty (30) days written notice be given to the City prior to any material modification or cancellation of such insurance. In the event of a material modification or cancellation of coverage, the City may terminate or Stop Work pursuant to the Contract Documents, unless the City receives, prior to such effective date, another properly executed original Certificate of Insurance and original copies of endorsements or certified original policies, including all endorsements and attachments thereto evidencing coverages set forth herein and the insurance required herein is in full force and effect. Contractor shall not take possession, or use the Project site, or commence operations under this Agreement until the City has been furnished original Certificate(s) of Insurance and certified original copies of Endorsements or policies of insurance including all Endorsements and any and all other attachments as required in this Section. The original Endorsements for each policy and the Certificate of Insurance shall be signed by an individual authorized by the insurance carrier to do so on its behalf.
- c. It is understood and agreed to by the parties hereto and the insurance company(s), that the Certificate(s) of Insurance and policies shall so covenant and shall be construed as primary, and the City's insurance and/or deductibles and/or self-insured retentions or self-insured programs shall not be construed as contributory.
- d. The City reserves the right to adjust the monetary limits of insurance coverage's during the term of this Contract including any extension thereof-if in the City's reasonable judgment, the amount or type of insurance carried by the Contractor becomes inadequate.
- e. Contractor shall pass down the insurance obligations contained herein to all tiers of sub-contractors working under this Contract.

GENERAL CONDITIONS



GC43. TIME FOR COMPLETION AND LIQUIDATED DAMAGES

- a. **Time for Completion/Liquidated Damages.** Work shall be commenced within ten (10) days of the date stated in the City's Notice to Proceed and shall be completed by Contractor in the time specified in the Contract Documents. The City is under no obligation to consider early completion of the Project; and the Contract completion date shall not be amended by the City's receipt or acceptance of the Contractor's proposed earlier completion date. Furthermore, Contractor shall not, under any circumstances, receive additional compensation from the City (including but not limited to indirect, general, administrative or other forms of overhead costs) for the period between the time of earlier completion proposed by the Contractor and the Contract completion date. If The Work is not completed as stated in the Contract Documents, it is understood that the City will suffer damage. In accordance with Government Code section 53069.85, being impractical and infeasible to determine the amount of actual damage, it is agreed that Contractor shall pay to the City as fixed and liquidated damages, and not as a penalty, **the sum of \$2,000 for each day of delay** until The Work is fully completed. Contractor and its surety shall be liable for any liquidated damages. Any money due or to become due the Contractor may be retained to cover liquidated damages.
- b. **Inclement Weather.** Contractor shall abide the Engineer's determination of what constitutes inclement weather. Time extensions for inclement weather shall only be granted when the Work stopped during inclement weather is on the critical path of the Project schedule.
- c. **Extension of Time.** Contractor shall not be charged liquidated damages because of any delays in completion of The Work due to unforeseeable causes beyond the control and without the fault or negligence of Contractor (or its subcontractors or suppliers). Contractor shall within five (5) Days of identifying any such delay notify the City in writing of causes of delay. The City shall ascertain the facts and extent of delay and grant extension of time for completing The Work when, in its judgment, the facts justify such an extension. Time extensions to the Project shall be requested by the Contractor as they occur and without delay. No delay claims shall be permitted unless the event or occurrence delays the completion of the Project beyond the Contract completion date.
- d. **No Damages for Reasonable Delay.** The City's liability to Contractor for delays for which the City is responsible shall be limited to only an extension of time unless such delays were unreasonable under the circumstances. In no case shall the City be liable for any costs which are borne by the Contractor in the regular course of business, including, but not limited to, home office overhead and other ongoing costs. Damages caused by unreasonable City delay, including delays caused by items that are the responsibility of the City pursuant to Government Code section



4215, shall be based on actual costs only, no proportions or formulas shall be used to calculate any delay damages.

GC44. COST BREAKDOWN AND PERIODIC ESTIMATES

Contractor shall furnish on forms Approved by the City:

- a. Within ten (10) Days of award of the Contract a detailed estimate giving a complete breakdown of the Contract price;
- b. A monthly itemized estimate of Work done for the purpose of making progress payments. In order for the City to consider and evaluate each progress payment application, the Contractor shall submit a detailed measurement of Work performed and a progress estimate of the value thereof before the tenth (10th) Day of the following month.
- c. Contractor shall submit, with each of its payment requests, an adjusted list of actual quantities, verified by the Engineer, for unit price items listed, if any, in the Bid Form.
- d. Following the City's Acceptance of the Work, the Contractor shall submit to the City a written statement of the final quantities of unit price items for inclusion in the final payment request.
- e. The City shall have the right to adjust any estimate of quantity and to subsequently correct any error made in any estimate for payment.

Contractor shall certify under penalty of perjury, that all cost breakdowns and periodic estimates accurately reflect the Work on the Project.

GC45. MOBILIZATION

- a. When a bid item is included in the Bid Form for mobilization, the costs of Work in advance of construction operations and not directly attributable to any specific bid item will be included in the progress estimate ("Initial Mobilization"). When no bid item is provided for "Initial Mobilization," payment for such costs will be deemed to be included in the other items of The Work. The bid amount for Mobilization shall **not exceed 5%** of contract amount.
- b. Payment for Initial Mobilization based on the lump sum provided in the Bid Form, which shall constitute full compensation for all such Work. No payment for Initial Mobilization will be made until all of the listed items have been completed to the satisfaction of the Engineer. The scope of the Work included under Initial Mobilization shall include, but shall not be limited to, the following principal items:
 1. Obtaining and paying for all bonds, insurance, and permits.



2. Moving on to the Project site of all Contractor's plant and equipment required for first month's operations.
3. Installing temporary construction power, wiring, and lighting facilities.
4. Establishing fire protection system.
5. Developing and installing a construction water supply.
6. Providing and maintaining the field office trailers for the Contractor and the Engineer, complete, with all specified furnishings and utility services including telephones, telephone appurtenances, computer and printer, and copying machine.
7. Providing on-site communication facilities for the Owner and the Engineer, including telephones, radio pagers, and fax machines.
8. Providing on-site sanitary facilities and potable water facilities as specified per Cal-OSHA and these Contract Documents.
9. Furnishing, installing, and maintaining all storage buildings or sheds required for temporary storage of products, equipment, or materials that have not yet been installed in the Work. All such storage shall meet manufacturer's specified storage requirements, and the specific provisions of the specifications, including temperature and humidity control, if recommended by the manufacturer, and for all security.
10. Arranging for and erection of Contractor's work and storage yard, including required project signage.
11. Posting all OSHA required notices and establishment of safety programs per Cal-OSHA.
12. Full-time presence of Contractor's superintendent at the job site as required herein.
13. Submittal of Construction Schedule as required by the Contract Documents.

GC46. PAYMENTS

- a. The City shall make monthly progress payments following receipt of undisputed and properly submitted payment requests. Contractor shall be paid a sum equal to ninety percent (95%) of the value of Work performed up to the last day of the previous month, less the aggregate of previous payments.

GENERAL CONDITIONS



- b. The Contractor shall, after the full completion of The Work, submit a final payment application. All prior progress estimates shall be subject to correction in the final estimate and payment.
- c. Unless otherwise required by law, the final payment of five percent (5%) of the value of the Work, if unencumbered, shall be paid no later than sixty (35) Days after the date of recordation of the Notice of Completion.
- d. Acceptance by Contractor of the final payment shall constitute a waiver of all claims against the City arising from this Contract.
- e. Payments to the Contractor shall not be construed to be an acceptance of any defective work or improper materials, or to relieve the Contractor of its obligations under the Contract Documents.
- f. The Contractor shall submit with each payment request the Contractor's conditional waiver of lien for the entire amount covered by such payment request, as well as a valid unconditional waiver of lien from the Contractor and all subcontractors and materialmen for all work and materials included in any prior invoices. Waivers of lien shall be in the forms prescribed by California Civil Code Section 3262. Prior to final payment by the City, the Contractor shall submit a final waiver of lien for the Contractor's work, together with releases of lien from any subcontractor or materialmen.

GC47. PAYMENTS WITHHELD AND BACKCHARGES

In addition to amounts which the City may retain under other provisions of the Contract Documents the City may withhold payments due to Contractor as may be necessary to cover:

- a. Stop Notice Claims.
- b. Defective work not remedied.
- c. Failure of Contractor to make proper payments to its subcontractors or suppliers.
- d. Completion of the Contract if there exists a reasonable doubt that the work can be completed for balance then unpaid.
- e. Damage to another contractor or third party.
- f. Amounts which may be due the City for claims against Contractor.
- g. Failure of Contractor to keep the record ("as-built") drawings up to date.
- h. Failure to provide updates on the construction schedule.



- i. Site clean up.
- j. Failure of the Contractor to comply with requirements of the Contract Documents.
- k. Liquidated damages.
- l. Legally permitted penalties.

Upon completion of the Contract, the City will reduce the final Contract amount to reflect costs charged to the Contractor, backcharges or payments withheld pursuant to the Contract Documents.

GC48. CHANGES AND EXTRA WORK

a. Change Order Work.

- 1) The City, without invalidating the Contract, may order changes in the Work consisting of additions, deletions or other revisions, the Contract amount and Contract time being adjusted accordingly. All such changes in the Work shall be authorized by Change Order, and shall be performed under the applicable conditions of the Contract Documents. A Change Order signed by the Contractor indicates the Contractor's agreement therewith, including any adjustment in the Contract amount or the Contract time, and the full and final settlement of all costs (direct, indirect and overhead) related to the Work authorized by the Change Order.
- 2) All claims for additional compensation to the Contractor shall be presented in writing before the expense is incurred and will be adjusted as provided herein. No work shall be allowed to lag pending such adjustment, but shall be promptly executed as directed, even if a dispute arises. No claim will be considered after the work in question has been done unless a written contract change order has been issued or a timely written notice of claim has been made by Contractor. Contractor shall not be entitled to claim or bring suit for damages, whether for loss of profits or otherwise, on account of any decrease or omission of any item or portion of Work to be done. Whenever any change is made as provided for herein, such change shall be considered and treated as though originally included in the Contract, and shall be subject to all terms, conditions and provisions of the original Contract.
- 3) Owner Initiated Change. The Contractor must submit a complete cost proposal, including any change in the Contract time, within seven (7) Days after receipt of a scope of a proposed change order, unless the City requests that proposals be submitted in less than seven (7) Days.



- 4) Contractor Initiated Change. The Contractor must give written notice of a proposed change order required for compliance with the Contract Documents within seven (7) Days of discovery of the facts giving rise to the proposed change order.
- 5) Whenever possible, any changes to the Contract amount shall be in a lump sum mutually agreed to by the Contractor and the City.
- 6) Price quotations from the Contractor shall be accompanied by sufficiently detailed supporting documentation to permit verification by the City.
- 7) If the Contractor fails to submit the cost proposal within the seven (7) Day period (or as requested), the City has the right to order the Contractor in writing to commence the work immediately on a force account basis and/or issue a lump sum change to the contract price in accordance with the City's estimate of cost. If the change is issued based on the City estimate, the Contractor will waive its right to dispute the action unless within fifteen (15) Days following completion of the added/deleted work, the Contractor presents written proof that the City's estimate was in error.
- 8) Estimates for lump sum quotations and accounting for cost-plus-percentage work shall be limited to direct expenditures necessitated specifically by the subject extra work, and shall be segregated as follows:
 - (a) Labor. The costs of labor will be the actual cost for wages prevailing locally for each craft or type of worker at the time the extra work is done, plus employer payments of payroll taxes and insurance, health and welfare, pension, vacation, apprenticeship funds, and other direct costs resulting from Federal, State or local laws, as well as assessment or benefits required by lawful collective bargaining agreements. The use of a labor classification which would increase the extra work cost will not be permitted unless the contractor establishes the necessity for such additional costs. Labor costs for equipment operators and helpers shall be reported only when such costs are not included in the invoice for equipment rental.
 - (b) Materials. The cost of materials reported shall be at invoice or lowest current price at which such materials are locally available in the quantities involved, plus sales tax, freight and delivery. Materials cost shall be based upon supplier or manufacturer's invoice. If invoices or other satisfactory evidence of cost are not furnished within fifteen (15) Days of delivery, then the Engineer shall determine the materials cost, at its sole discretion.
 - (c) Tool and Equipment Use. No payment will be made for the use of small tools, tools which have a replacement value of \$1,000 or less.

GENERAL CONDITIONS



Regardless of ownership, the rates to be used in determining equipment use costs shall not exceed listed rates prevailing locally at equipment rental agencies, or distributors, at the time the work is performed.

- (d) Overhead, Profit and Other Charges. The mark-up for overhead (including supervision) and profit on work added to the Contract shall be according to the following:
- i. "Net Cost" is defined as consisting of costs of labor, materials and tools and equipment only excluding overhead and profit. The costs of applicable insurance and bond premium will be reimbursed to the Contractor and subcontractors at cost only, without mark-up.
 - ii. For Work performed by the Contractor's forces the added cost for overhead and profit shall not exceed fifteen (15%) percent of the Net Cost of the Work.
 - iii. For Work performed by a subcontractor, the added cost for overhead and profit shall not exceed fifteen (15%) percent of the Net Cost of the Work to which the Contractor may add five (5%) percent of the subcontractor's Net Cost.
 - iv. For Work performed by a sub-subcontractor the added cost for overhead and profit shall not exceed fifteen (15 %) percent of the Net Cost for Work to which the subcontractor and general contractor may each add an additional five (5 %) percent of the Net Cost of the lower tier subcontractor.
 - iv. No additional mark up will be allowed for lower tier subcontractors, and in no case shall the added cost for overhead and profit payable by City exceed twenty-five (25%) percent of the Net Cost as defined herein.
- 9) For added or deducted Work by subcontractors, the Contractor shall furnish to the City the subcontractor's signed detailed estimate of the cost of labor, material and equipment, including the subcontractor markup for overhead and profit. The same requirement shall apply to sub-subcontractors.
- 10) For added or deducted work furnished by a vendor or supplier, the Contractor shall furnish to the City a detailed estimate or quotation of the cost to the Contractor, signed by such vendor or supplier.

GENERAL CONDITIONS



- 11) Any change in The Work involving both additions and deletions shall indicate a net total cost, including subcontracts and materials. Allowance for overhead and profit, as specified herein, shall be applied if the net total cost is an extra; overhead and profit allowances shall not be applied if the net total cost is a credit. The estimated cost of deductions shall be based on labor and material prices on the date the Contract was executed.
- 12) Contractor shall not reserve a right to assert impact costs, extended job site costs, extended overhead, constructive acceleration and/or actual acceleration beyond what is stated in the change order for work. No claims shall be allowed for impact, extended overhead costs, constructive acceleration and/or actual acceleration due to a multiplicity of changes and/or clarifications. The Contractor may not change or modify the City's change order form in an attempt to reserve additional rights.
- 13) If the City disagrees with the proposal submitted by Contractor, it will notify the Contractor and the City will provide its opinion of the appropriate price and/or time extension. If the Contractor agrees with the City, a change order will be issued by the City. If no agreement can be reached, the City shall have the right to issue a unilateral change order setting forth its determination of the reasonable additions or savings in costs and time attributable to the extra or deleted work. Such determination shall become final and binding if the Contractor fails to submit a claim in writing to the City within fifteen (15) Days of the issuance of the unilateral change order, disputing the terms of the unilateral change order.
- 14) No dispute, disagreement or failure of the parties to reach agreement on the terms of the change order shall relieve the Contractor from the obligation to proceed with performance of the work, including extra work, promptly and expeditiously.
- 15) Any alterations, extensions of time, extra work or any other changes may be made without securing consent of the Contractor's surety or sureties.

GC49. OCCUPANCY

The City reserves the right to occupy or utilize any portion of The Work at any time before completion, and such occupancy or use shall not constitute Acceptance of any part of Work covered by this Contract. This use shall not relieve the Contractor of its responsibilities under the Contract.

GC50. INDEMNIFICATION

Contractor shall defend (with counsel of City's choosing), indemnify and hold the City, its officials, officers, agents, employees, and representatives free and harmless from any and all claims, demands, causes of action, costs, expenses, liabilities, losses, damages

GENERAL CONDITIONS



or injuries, in law or equity, regardless of whether the allegations are false, fraudulent, or groundless, to property or persons, including wrongful death, to the extent arising out of or incident to any acts, omissions or willful misconduct of Contractor, its officials, officers, employees, agents, consultants and contractors arising out of or in connection with the performance of the Work or this Contract, including claims made by subcontractors for nonpayment, including without limitation the payment of all consequential damages and attorney's fees and other related costs and expenses. Contractor shall defend, at Contractor's own cost, expense and risk, with counsel of City's choosing, any and all such aforesaid suits, actions or other legal proceedings of every kind that may be brought or instituted against City, its officials, officers, agents, employees and representatives. To the extent of its liability, Contractor shall pay and satisfy any judgment, award or decree that may be rendered against City, its officials, officers, employees, agents, employees and representatives, in any such suit, action or other legal proceeding. Contractor shall reimburse City, its officials, officers, agents, employees and representatives for any and all legal expenses and costs incurred by each of them in connection therewith or in enforcing the indemnity herein provided. The only limitations on this provision shall be those imposed by Civil Code Section 2782.

GC51. RECORD ("AS BUILT") DRAWINGS

- a. Contractor shall prepare and maintain a complete set of record drawings (herein referred to as "as-builts") and shall require each trade to prepare its own as-builts. The as-builts must show the entire site for each major trade, including but not limited to water, sewer, electrical, data, telephone, cable, fire alarm, gas and plumbing. Contractor shall mark the as-builts to show the actual installation where the installation varies from the Work as originally shown. Contractor shall mark whichever drawings are most capable of showing conditions fully and where shop drawings are used, Contractor must record a cross-reference at the corresponding location on the contract drawings. Contractor shall give particular attention to concealed elements that would be difficult to measure and record at a later date. Contractor shall use colors to distinguish variations in separate categories of The Work.
- b. Contractor shall note related change order numbers where applicable. Contractor shall organize as-builts into manageable sets, bound with durable paper cover sheets and shall print suitable title, dates and other identification on the cover of each set. Contractor to also provide an electronic version of the as-builts. The suitability of the as-builts will be determined by the Engineer.

GC52. RESOLUTION OF CONSTRUCTION CLAIMS

- a. In accordance with Public Contract Code Sections 20104 *et seq.* and other applicable law, public works claims of \$375,000 or less which arise between the Contractor and the City shall be resolved under the following the statutory



procedure unless the City has elected to resolve the dispute pursuant to Public Contract Code Section 10240 *et seq.*

- b. **All Claims:** All claims shall be submitted in writing and accompanied by substantiating documentation. Claims must be filed on or before the date of final payment unless other notice requirements are provided in the contract. "Claim" means a separate demand by the claimant for (1) a time extension, (2) payment of money or damages arising from work done by or on behalf of the claimant and payment of which is not otherwise expressly provided for or the claimant is not otherwise entitled, or (3) an amount the payment of which is disputed by the City.
- c. **Claims Under \$50,000.** The City shall respond in writing to the claim within 45 days of receipt of the claim, or, the City may request, in writing, within 30 days of receipt of the claim, any additional documentation supporting the claim or relating to defenses or claims the City may have. If additional information is needed thereafter, it shall be provided upon mutual agreement of the City and the claimant. The City's written response shall be submitted 15 days after receiving the additional documentation, or within the same period of time taken by the claimant to produce the additional information, whichever is greater.
- d. **Claims over \$50,000 but less than or equal to \$375,000.** The City shall respond in writing within 60 days of receipt, or, may request in writing within 30 days of receipt of the claim, any additional documents supporting the claim or relating to defenses or claims the City may have against the claimant. If additional information is needed thereafter, it shall be provided pursuant to mutual agreement between the City and the claimant. The City's response shall be submitted within 30 days after receipt of the further documents, or within the same period of time taken by the claimant to produce the additional information or documents, whichever is greater. The Contractor shall make these records and documents available at all reasonable times, without any direct charge.
- e. The Contractor will submit the claim justification in the following format:
 - 1) Summary of claim merit and price, and Contract clause pursuant to which the claim is made.
 - 2) List of documents relating to claim
 - (a) Specifications
 - (b) Drawings
 - (c) Clarifications (Requests for Information)
 - (d) Schedules



- (e) Other
 - 3) Chronology of events and correspondence
 - 4) Analysis of claim merit
 - 5) Analysis of claim cost
 - 6) Analysis of time impact analysis in CPM format
 - 7) Cover letter and certification of validity of the claim
- f. If the claimant disputes the City's response, or if the City fails to respond within the statutory time period(s), the claimant may so notify the City within 15 days of the receipt of the response or the failure to respond, and demand an informal conference to meet and confer for settlement. Upon such demand, the City shall schedule a meet and confer conference within 30 Days.
- g. If following the meet and confer conference, the claim or any portion thereof remains in dispute, the claimant may file a claim pursuant to Government Code 900 et seq. and Government Code 910 et seq. For purposes of those provisions, the time within which a claim must be filed shall be tolled from the time the claimant submits the written claim until the time the claim is denied, including any time utilized for the meet and confer conference.
- h. Submission of a claim, properly certified, with all required supporting documentation, and written rejection or denial of all or part of the claim by City, is a condition precedent to any action, proceeding, litigation, suit, general conditions claim, or demand for arbitration by Contractor.

GC53. CITY'S RIGHT TO TERMINATE CONTRACT

- a. **Termination for Cause:** The City may, without prejudice to any other right or remedy, serve written notice upon Contractor of its intention to terminate this Contract if the Contractor: (i) refuses or fails to prosecute The Work or any part thereof with such diligence as will ensure its completion within the time required; (ii) fails to complete The Work within the required time; (iii) should file a bankruptcy petition or be adjudged a bankrupt; (iv) should make a general assignment for the benefit of its creditors; (v) should have a receiver appointed; (vi) should persistently or repeatedly refuse or fail to supply enough properly skilled workers or proper materials to complete the work; (vii) should fail to make prompt payment to subcontractors or for material or labor; (viii) persistently disregard laws, ordinances, other requirements or instructions of the City; or (ix) should violate any of the provisions of the Contract Documents.



The notice of intent to terminate shall contain the reasons for such intention to terminate. Unless within ten (10) Days after the service of such notice, such condition shall cease or satisfactory arrangements (acceptable to the City) for the required correction are made, this Contract shall be terminated. In such case, Contractor shall not be entitled to receive any further payment until the Project has been finished. The City may take over and complete The Work by any method it may deem appropriate. Contractor and its surety shall be liable to the City for any excess costs or other damages incurred by the City to complete the Project. If the City takes over The Work, the City may, without liability for so doing, take possession of and utilize in completing The Work such materials, appliances, plant, and other property belonging to the Contractor as may be on the Project site.

- b. **Termination For Convenience:** The City may terminate performance of The Work in whole or, in part, if the City determines that a termination is in the City's interest.

The Contractor shall terminate all or any part of The Work upon delivery to the Contractor of a Notice of Termination specifying that the termination is for the convenience of the City, the extent of termination, and the effective date of such termination.

After receipt of Notice of Termination, and except as directed by the City, the Contractor shall, regardless of any delay in determining or adjusting any amounts due under this Termination for Convenience clause, immediately proceed with the following obligations:

- 1) Stop Work as specified in the Notice.
- 2) Complete any Work specified in the Notice of Termination in a least cost/shortest time manner while still maintaining the quality called for under the Contract Documents.
- 3) Leave the property upon which the Contractor was working and upon which the facility (or facilities) forming the basis of the Contract Documents is situated in a safe and sanitary manner such that it does not pose any threat to the public health or safety.
- 4) Terminate all subcontracts to the extent that they relate to the portions of The Work terminated.
- 5) Place no further subcontracts or orders, except as necessary to complete the remaining portion of The Work.
- 6) Submit to the City, within ten (10) Days from the effective date of the Notice of Termination, all of the documentation called for by the

GENERAL CONDITIONS



Contract Documents to substantiate all costs incurred by the Contractor for labor, materials and equipment through the Effective Date of the Notice of Termination. Any documentation substantiating costs incurred by the Contractor solely as a result of the City's exercise of its right to terminate this Contract pursuant to this clause, which costs the Contractor is authorized under the Contract Documents to incur, shall: (i) be submitted to and received by the City no later than thirty (30) Days after the Effective Date of the Notice of Termination; (ii) describe the costs incurred with particularity; and (iii) be conspicuously identified as "Termination Costs Occasioned by the City's Termination for Convenience."

- 7) These provisions are in addition to and not in limitation of any other rights or remedies available to the City.
- c. Notwithstanding any other provision of this Article, when immediate action is necessary to protect life and safety or to reduce significant exposure or liability, the City may immediately order Contractor to cease Work on the Project until such safety or liability issues are addressed to the satisfaction of the City or the Contract is terminated.

GC54. WARRANTY AND GUARANTEE

- a. Contractor warrants that all materials and equipment furnished under this Contract shall be new unless otherwise specified in the Contract Documents; and that all Work conforms to the Contract Document requirements and is free of any defect whether performed by the Contractor or any subcontractor or supplier.
- b. Unless otherwise stated, all warranty periods shall begin upon the filing of the Notice of Completion. Unless otherwise stated, the warranty period shall be for one year.
- c. The Contractor shall remedy at its expense any damage to City-owned or controlled real or personal property.
- d. Contractor shall furnish the City with all warranty and guarantee documents prior to final Acceptance of the Project by the City.
- e. The City shall notify the Contractor, in writing, within a reasonable time after the discovery of any failure, defect, or damage. The Contractor shall within ten (10) Days after being notified commence and perform with due diligence all necessary Work. If the Contractor fails to promptly remedy any defect, or damage; the county shall have the right to replace, repair, or otherwise remedy the defect, or damage at the Contractor's expense.



- f. In the event of any emergency constituting an immediate hazard to health, safety, property, or licensees, when caused by Work of the Contractor not in accordance with the Contract requirements, the City may undertake at Contractor's expense, and without prior notice, all Work necessary to correct such condition.
- g. With respect to all warranties, express or implied, from subcontractors, manufacturers, or suppliers for Work performed and Materials furnished under this Contract, the Contractor shall:
 - 1) Obtain for City all warranties that would be given in normal commercial practice;
 - 2) Require all warranties to be executed, in writing, for the benefit of the City; and
 - 3) Enforce all warranties for the benefit of the City, unless otherwise directed in writing by the City.

This Article shall not limit the City's rights under this Contract or with respect to latent defects, gross mistakes, or fraud. The City specifically reserves all rights related to defective work, including but not limited to the defect claims pursuant to California Code of Civil Procedure Section 337.15.

GC55. DOCUMENT RETENTION & EXAMINATION

- a. In accordance with Government Code Section 8546.7, records of both the City and the Contractor shall be subject to examination and audit by the State Auditor General for a period of three (3) years after final payment.
- b. Contractor shall make available to the City any of the Contractor's other documents related to the Project immediately upon request of the City.
- c. In addition to the State Auditor rights above, the City shall have the right to examine and audit all books, estimates, records, contracts, documents, bid documents, subcontracts, and other data of the Contractor (including computations and projections) related to negotiating, pricing, or performing the modification in order to evaluate the accuracy and completeness of the cost or pricing data at no additional cost to the City, for a period of four (4) years after final payment.

GC56. SOILS INVESTIGATIONS

When a soils investigation report for the Project site is available, such report shall not be a part of the Contract Documents. Any information obtained from such report as to subsurface soil condition, or to elevations of existing grades or elevations of underlying rock, is approximate only and is not guaranteed. Contractor acknowledges that any soils



investigation report (including any borings) was prepared for purposes of design only and Contractor is required to examine the site before submitting its bid and must make whatever tests it deems appropriate to determine the underground condition of the soil.

GC57. SEPARATE CONTRACTS

- a. The City reserves the right to let other contracts in connection with this Work or on the Project site. Contractor shall permit other contractors reasonable access and storage of their materials and execution of their work and shall properly connect and coordinate its Work with theirs.
- b. To ensure proper execution of its subsequent Work, Contractor shall immediately inspect work already in place and shall at once report to the Engineer any problems with the work in place or discrepancies with the Contract Documents.
- c. Contractor shall ascertain to its own satisfaction the scope of the Project and nature of any other contracts that have been or may be awarded by the City in prosecution of the Project to the end that Contractor may perform this Contract in the light of such other contracts, if any. Nothing herein contained shall be interpreted as granting to Contractor exclusive occupancy at site of the Project. Contractor shall not cause any unnecessary hindrance or delay to any other contractor working on the Project. If simultaneous execution of any contract for the Project is likely to cause interference with performance of some other contract or contracts, the Engineer shall decide which Contractor shall cease Work temporarily and which contractor shall continue or whether work can be coordinated so that contractors may proceed simultaneously. The City shall not be responsible for any damages suffered or for extra costs incurred by Contractor resulting directly or indirectly from award, performance, or attempted performance of any other contract or contracts on the Project site.

GC58. NOTICE AND SERVICE THEREOF

All notices shall be in writing and either served by personal delivery or mailed to the other party as designated in the Bid Forms. Written notice to the Contractor shall be addressed to Contractor's principal place of business unless Contractor designates another address in writing for service of notice. Notice to City shall be addressed to the City as designated in the Notice Inviting Bids unless City designates another address in writing for service of notice. Notice shall be effective upon receipt or five (5) Days after being sent by first class mail, whichever is earlier. Notice given by facsimile shall not be effective unless acknowledged in writing by the receiving party.

GC59. NOTICE OF THIRD PARTY CLAIMS

Pursuant to Public Contract Code Section 9201, the City shall provide Contractor with timely notification of the receipt of any third-party claim relating to the Contract.



GC60. STATE LICENSE BOARD NOTICE.

Contractors are required by law to be licensed and regulated by the Contractors' State License Board which has jurisdiction to investigate complaints against contractors if a complaint regarding a patent act or omission is filed within four (4) years of the date of the alleged violation. A complaint regarding a latent act or omission pertaining to structural defects must be filed within ten (10) years of the date of the alleged violation. Any questions concerning a contractor may be referred to the Registrar, Contractors' State License Board, P.O. Box 26000, Sacramento, California 95826.

GC61. INTEGRATION

- a. Oral Modifications Ineffective. No oral order, objection, direction, claim or notice by any party or person shall affect or modify any of the terms or obligations contained in the Contract Documents.
- b. Contract Documents Represent Entire Contract. The Contract Documents represent the entire agreement of the City and Contractor.

GC62. ASSIGNMENT

Contractor shall not assign, transfer, convey, sublet, or otherwise dispose of this Contract or any part thereof including any claims, without prior written consent of the City. Any assignment without the written consent of the City shall be void. Any assignment of money due or to become due under this Contract shall be subject to a prior lien for services rendered or Material supplied for performance of Work called for under the Contract Documents in favor of all persons, firms, or corporations rendering such services or supplying such Materials to the extent that claims are filed pursuant to the Civil Code, the Code of Civil Procedure or the Government Code.

GC63. CHANGE IN NAME AND NATURE OF CONTRACTOR'S LEGAL ENTITY

Should a change be contemplated in the name or nature of the Contractor's legal entity, the Contractor shall first notify the City in order that proper steps may be taken to have the change reflected on the Contract.

GC64. ASSIGNMENT OF ANTITRUST ACTIONS

Pursuant to Section 7103.5 of the Public Contract Code, in entering into a public works contract or subcontract to supply goods, services, or materials pursuant to a public works contract, Contractor or subcontractor offers and agrees to assign to the City all rights, title, and interest in and to all causes of action it may have under Section 4 of the Clayton Act (15 U.S.C. Section 15) or under the Cartwright Act (chapter 2 (commencing with Section 16700) of part 2 of division 7 of the Business and Professions Code), arising from the purchase of goods, services, or materials pursuant to this Contract or any



subcontract. This assignment shall be made and become effective at the time the City makes final payment to the Contractor, without further acknowledgment by the parties.

GC65. PROHIBITED INTERESTS

No City official or representative who is authorized in such capacity and on behalf of the City to negotiate, supervise, make, accept, or approve, or to take part in negotiating, supervising, making, accepting or approving any engineering, inspection, construction or material supply contract or any subcontract in connection with construction of the project, shall be or become directly or indirectly interested financially in the Contract.

GC66. LAWS AND REGULATIONS

- a. Contractor shall give all notices and comply with all federal, state and local laws, ordinances, rules and regulations bearing on conduct of work as indicated and specified by their terms. References to specific laws, rules or regulations in this Contract are for reference purposes only, and shall not limit or affect the applicability of provisions not specifically mentioned. If Contractor observes that drawings and specifications are at variance therewith, he shall promptly notify the Engineer in writing and any necessary changes shall be adjusted as provided for in this Contract for changes in work. If Contractor performs any work knowing it to be contrary to such laws, ordinances, rules and regulations, and without such notice to the Engineer, he shall bear all costs arising therefrom.
- b. Contractor shall be responsible for familiarity with the Americans with Disabilities Act ("ADA") (42 U.S.C. § 12101 et seq.). The Work will be performed in compliance with ADA laws, rules and regulations. Contractor shall comply with the Historic Building Code, including, but not limited to, as it relates to the ADA, whenever applicable.
- c. Contractor acknowledges and understands that, pursuant to Public Contract Code Section 20676, sellers of "mined material" must be on an approved list of sellers published pursuant to Public Resources Code Section 2717(b) in order to supply mined material for this Contract.

GC67. PATENT FEES OR ROYALTIES.

The Contractor shall include in its bid amount the patent fees or royalties on any patented article or process furnished or used in the Work. Contractor shall assume all liability and responsibility arising from the use of any patented, or allegedly patented, materials, equipment, devices or processes used in or incorporated with The Work, and shall defend, indemnify and hold harmless the City, its officials, officers, agents, employees and representatives from and against any and all liabilities, demands, claims, damages, losses, costs and expenses, of whatsoever kind or nature, arising from such use.



GC68. OWNERSHIP OF DRAWING

All Contract Documents furnished by the City are City property. They are not to be used by Contractor or any subcontractor on other work nor shall Contractor claim any right to such documents. With exception of one complete set of Contract Documents, all documents shall be returned to the City on request at completion of The Work.

GC69. NOTICE OF TAXABLE POSSESSORY INTEREST

In accordance with Revenue and Taxation Code Section 107.6, the Contract Documents may create a possessory interest subject to personal property taxation for which Contractor will be responsible.



03 SPECIAL FEDERAL PROVISIONS

CITYWIDE SIDEWALK IMPROVEMENTS CIP R-24

County of Riverside
Housing & Workforce Solutions (HWS)

SPECIAL FEDERAL PROVISIONS

CONSTRUCTION BID DOCUMENT

Projects Over \$200,000

Community Development Block Grant

Construction Activities

**SPECIAL FEDERAL PROVISIONS
DOCUMENT INDEX**

General Information

1. General Summary
 2. Hold Harmless Clause and Additional Insured-Insurance Requirements
 3. B-1 Federal Labor Standards Provisions (HUD 4010)
 4. B-2 Federal Prevailing Wage Decision (CA _____ Mod. _____)
 5. B-3 Project Sign (SAMPLE)
 6. B-5 County of Riverside Section 3 Program Overview (Applicable for Projects \$200,000 or more)
 7. Additional Federal Requirements
-

Bid Forms

8. B-4 Certification of Bidder Regarding Non-Segregated Facilities (Required for all Projects)
9. B-6 Section 3 Implementation Plan (Required for Projects \$200,000 or more)
10. B-7 Certification for Section 3 Compliance (Required for Projects \$200,000 or more)
11. B-8 Bidder's Certification on Federal Contract Requirements (Required for all Projects)
12. B-8 Questionnaire Regarding Bidders (Required for all Projects)
13. B-10 List of Subcontractors and Suppliers (Required for all Projects)

Must be completed by all Subcontractors

14. B-6 Section 3 Implementation Plan (Required for Projects \$200,000 or more)
15. B-7 Certification for Section 3 Compliance (Required for Projects \$200,000 or more)

Post-Award Forms

16. PA-1 Performance Bond (100% of contract price) (Required for Projects \$200,000 or more)
17. PA-2 Payment Bond (Required for Projects \$200,000 or more)
18. PA-3 Subcontractor Questionnaire (Required for all Projects)
19. PA-4 Subcontractor Certification Regarding Non-segregated Facilities (Required for all Projects)
20. PA-5 List of Permanent Employees/Section 3 Worker Employer Certification (Required for Projects \$200,000 or more)
21. PA-6 Documentation of Qualitative Efforts (Required for Projects \$200,000 or more)
22. PA-7 Davis-Bacon Classifications and Pay Rates (Required for all Projects)

GENERAL SUMMARY

The following Federal Provisions and the attached exhibits herewith become binding on the contractor(s) and incorporated in the Bid Document in their entirety.

1. The Contractor and the Subcontractor(s) shall perform all work in accordance with the project plans and specifications, including all stipulations designed to meet diversified Federal Environmental Architectural, the Architectural Barriers Act of 1968, as amended; the Americans with Disabilities Act of 1990, Public Law 101-336, as amended.
2. The Contractor and the Subcontractor(s) shall allow all authorized Federal, State Comptroller, and/or County officials access to the work area, fiscal, payroll, materials and other relevant contract records which are directly pertinent to that specific contract for the purpose of making audit, examination, excerpts, and transcriptions. All relevant records must be retained for at least four years.
3. The Contractor and the Subcontractor(s) shall comply with the Lead Based Paint Poisoning Prevention Act and the Implementation Regulations (24 CFR 35) issued pursuant thereto and any amendments thereof.
4. The Contractor and the Subcontractor(s) shall comply with Section 503 of the Rehabilitation Act of 1973 (P.L. 93-112) and the Implementation Regulations (41 CFR 60-741) issued pursuant thereto and any amendments thereof.
5. The Contractor and the Subcontractor(s) shall comply with Section 40-2, Vietnam Era Veterans Adjustment Assistance Act of 1974 and the Implementation Regulations (41 CFR 60-250) issued pursuant thereto and any amendment thereof.
6. The Contractor and the Subcontractor(s) shall comply with the Title IV of the Civil Rights Act of 1964 and the Title VIII of the Civil Rights Act of 1963 and any amendment thereof.
7. For projects \$200,000 or over, the Contractor and the Subcontractor(s) shall comply with Clean Air Act of 1963 (P.L. 90-148) and the Federal Water Pollution Act (P.L. 92-500), as amended and all applicable standards or regulations (40 CFR Part 15 and 61) issued pursuant to the said acts.
8. For projects \$2,000 or over, the Contractor and the Subcontractor(s) shall comply with the Davis-Bacon Fair Labor Standards Act (40 USC a-276 a-5), and the implementation regulations issued pursuant thereto (29 CFR Section 1, 5) and any amendments thereof. Pursuant to the said regulations, **Exhibit B-1 and B-2** entitled "Federal Labor Standards Provisions" and "Federal Prevailing Wage Decision" respectively are herewith attached.
9. The Contractor and Subcontractor(s) shall comply with the Copeland Anti Kickback Act (40 USC 276 C) and the Implementation regulations (29 CFR 3) issued pursuant thereto and any amendments thereof. **Exhibit B-1** contains the key provisions of the said act.

10. For construction projects \$2,000 or over, or other projects \$2,500 or more which utilize mechanics or laborers the Contractor and the Subcontractor(s) shall comply with the Contract Work Hours and Safety Standards Act (40 USC 327-332) and the Implementation Regulations (29 CFR 5) issued pursuant thereto and any amendments thereof. **Exhibit B-1** contains the key provisions of the said act.
11. For projects \$25,000 or over the Contractor shall provide one sign board to be located as directed by the owner. The sign board shall be mounted in an acceptable manner and constructed as shown and specified in **Exhibit B-3**. Additional information can be added to the project sign at the request of the project sponsor.
12. The Contractor shall comply with all laws, ordinances, and regulations applicable to the work. If the Contractor ascertains at any time that any of the requirements of the contract are at variance with applicable law, ordinances, regulations or building code requirements, he shall promptly notify the owner and the Executive Director of Riverside County's Department of Housing & Workforce Solutions and shall not proceed with the work in question, except at his own risk, until the owner and the said Director has had an opportunity to determine the extent of the responsibility for the variance and the appropriate corrective actions undertaken.
13. The Contractor must complete and execute the attached Certification of Bidder Regarding Segregated Facilities **Exhibit B-4** and submit with the bid.
14. Wherever applicable, the Contractor and the Subcontractor(s) shall comply with, Uniform Administrative Requirements for Grants and Cooperative Agreements to State, Local and Federally Recognized Indian Tribal Governments, 24 CFR Part 85 or Uniform Requirements for Assistance to State and Local Governments, Circular A-102; Whichever is applicable.
15. For projects \$200,000 or over the Contractor shall furnish to the owner, a Performance bond, a Payment bond, and Materials Bond executed as surety by a corporation acceptable to the owner and authorized to issue surety bonds in the State of California. Such a performance bond and a payment bond and materials bond shall be for one hundred percent (100%) of the total contract price. (Attached herewith are recommended formats for said bonds, **Exhibits PA-1 and PA-2**.)
16. The Contractor and the Subcontractor(s) shall comply with Section 3 of The Housing and Community Development Act of 1968 and the regulations (24 CFR Part 75) issued pursuant thereto and amendments thereof. Pursuant to the said act, the Contractor and the Subcontractor(s) shall comply with the attached County of Riverside Section 3 Implementation Plan **Exhibits B-5, B-6, and PA-6**. The Contractor and Sub-contractor(s) must submit **Exhibit B-6**, for all projects over \$200,000, as part of the bid package.
17. The Contractor and Sub-contractor(s) must submit the attached, **Exhibit B-8**, certification that "he/she fully understands the diversified Federal requirements imposed on the Contractor(s) and Sub-contractor(s) of HUD funded construction projects", as part of the bid package.

18. Wherever applicable, the Contractor and the Sub-contractor(s) shall comply with Section 109 of The Housing and Community Development Act of 1974 and the Implementation Regulations (24 CFR 570.601) issued pursuant thereto and any amendments thereof.
19. For projects \$200,000 or over the Contractor shall submit a Bid Guarantee Bond in an amount no less than 5% of the total contract price, along with the bid.
20. The Contractor and Sub-contractor(s) shall comply with the Section 3 Reporting Requirements by completing the attachment **Exhibit B-7** entitled, "Certification for Section 3 Compliance," and submit with bid for all projects \$200,000 and over.
21. Federal Employee Benefit Clause: No member of or delegate to the congress of the United States, and no Resident Commissioner shall be admitted to any share or part of this agreement or to any benefit to arise from the same.
22. The Contractor must submit Questionnaire Regarding Bidders **Exhibit B-9** and List of Sub-contractors **Exhibit B-10** as part of the bid package. These forms are considered part of the Federal Contracting Requirements and are included in the bid document. Both documents are required to be completed by the Prime Contractor.
23. The Contractor shall follow mandatory standards and policies relating to energy efficiency which are contained in the state energy conservation plan issued in compliance with the Energy Policy and Conservation Act (Pub. L. 94-163, 89 Stat. 871). [53 FR 8068,8087, Mar. 11, 1988, as amended at 60 FR 19639,19642, April 19, 1995]
24. Contractor must comply with awarding agency (HUD) requirements and regulations pertaining to copyrights and rights in data.
25. Contractor will comply with Notice of awarding agency requirements and regulations pertaining to patent rights with respect to any discovery or invention which arises or is developed in the course of or under such contract.
26. Contractor will comply with notice of awarding agency requirements and regulations pertaining to reporting.

HOLD HARMLESS CLAUSE/INSURANCE REQUIREMENTS

The following County of Riverside Hold Harmless and Insurance provisions herewith become binding on the contractor(s) in their entirety.

HOLD HARMLESS/INDEMNIFICATION

CONTRACTOR shall indemnify and hold harmless the County of Riverside, its Agencies, Districts, Special Districts and Departments, their respective directors, officers, Board of Supervisors, elected and appointed officials, employees, agents and representatives (individually and collectively hereinafter referred to as Indemnitees) from any liability whatsoever, based or asserted upon any services of CONTRACTOR, its officers, employees, subcontractors, agents or representatives arising out of or in any way relating to this Agreement, including but not limited to property damage, bodily injury, or death or any other element of any kind or nature whatsoever arising from the performance of CONTRACTOR, its officers, employees, subcontractors, agents or representatives Indemnitors from this Agreement. CONTRACTOR shall defend, at its sole expense, all costs and fees including, but not limited, to attorney fees, cost of investigation, defense and settlements or awards, the Indemnitees in any claim or action based upon such alleged acts or omissions.

With respect to any action or claim subject to indemnification herein by CONTRACTOR, CONTRACTOR shall, at their sole cost, have the right to use counsel of their own choice and shall have the right to adjust, settle, or compromise any such action or claim without the prior consent of COUNTY; provided, however, that any such adjustment, settlement or compromise in no manner whatsoever limits or circumscribes CONTRACTOR'S indemnification to Indemnitees as set forth herein.

CONTRACTOR'S obligation hereunder shall be satisfied when CONTRACTOR has provided to COUNTY the appropriate form of dismissal relieving COUNTY from any liability for the action or claim involved. The specified insurance limits required in this Agreement shall in no way limit or circumscribe CONTRACTOR'S obligations to indemnify and hold harmless the Indemnitees herein from third party claims. In the event there is conflict between this clause and California Civil Code Section 2782, this clause shall be interpreted to comply with Civil Code 2782. Such interpretation shall not relieve the CONTRACTOR from indemnifying the Indemnitees to the fullest extent allowed by law.

INSURANCE

Without limiting or diminishing the CONTRACTOR'S obligation to indemnify or hold the COUNTY harmless, CONTRACTOR shall procure and maintain or cause to be maintained, at its sole cost and expense, the following insurance coverage's during the term of this Agreement. As respects to the insurance section only, the COUNTY herein refers to the County of Riverside, its Agencies, Districts, Special Districts, and Departments, their respective directors, officers, Board of Supervisors, employees, elected or appointed officials, agents or representatives as Additional Insureds.

A. Workers' Compensation:

If the CONTRACTOR has employees as defined by the State of California, the CONTRACTOR shall maintain statutory Workers' Compensation Insurance (Coverage A) as prescribed by the laws of the State of California. Policy shall include Employers' Liability (Coverage B) including Occupational Disease with limits not less than \$1,000,000 per person per accident. The policy shall be endorsed to waive subrogation in favor of The County of Riverside.

B. Commercial General Liability:

Commercial General Liability insurance coverage, including but not limited to, premises liability,

unmodified contractual liability, products and completed operations liability, personal and advertising injury, and cross liability coverage, covering claims which may arise from or out of CONTRACTOR'S performance of its obligations hereunder. Policy shall name the COUNTY as Additional Insured. Policy's limit of liability shall not be less than \$1,000,000 per occurrence combined single limit. If such insurance contains a general aggregate limit, it shall apply separately to this agreement or be no less than two (2) times the occurrence limit.

C. Vehicle Liability:

If vehicles or mobile equipment are used in the performance of the obligations under this Agreement, then CONTRACTOR shall maintain liability insurance for all owned, non-owned or hired vehicles so used in an amount not less than \$1,000,000 per occurrence combined single limit. If such insurance contains a general aggregate limit, it shall apply separately to this agreement or be no less than two (2) times the occurrence limit. Policy shall name the COUNTY as Additional Insureds.

D. Professional Liability

(ONLY TO BE INCLUDED IN CONTRACTS WITH SERVICE PROVIDERS INCLUDING BUT NOT LIMITED TO ENGINEERS, DOCTORS, AND LAWYERS) Contractor shall maintain Professional Liability Insurance providing coverage for the Contractor's performance of work included within this Agreement, with a limit of liability of not less than \$1,000,000 per occurrence and \$2,000,000 annual aggregate. If Contractor's Professional Liability Insurance is written on a claims made basis rather than an occurrence basis, such insurance shall continue through the term of this Agreement and CONTRACTOR shall purchase at his sole expense either 1) an Extended Reporting Endorsement (also, known as Tail Coverage); or 2) Prior Dates Coverage from new insurer with a retroactive date back to the date of, or prior to, the inception of this Agreement; or 3) demonstrate through Certificates of Insurance that Contractor has Maintained continuous coverage with the same or original insurer. Coverage provided under items; 1), 2) or 3) will continue for a period of five (5) years beyond the termination of this Agreement.

E. General Insurance Provisions- All Lines:

a) Any insurance carrier providing insurance coverage hereunder shall be admitted to the State of California and have an A M BEST rating of not less than A: VIII (A:8) unless such requirements are waived, in writing, by the County Risk Manager. If the County's Risk Manager waives a requirement for a particular insurer such waiver is only valid for that specific insurer and only for one policy term.

b) The Contractor's insurance carrier(s) must declare its insurance deductibles or self-insured retentions. If such deductibles or self-insured retentions exceed \$500,000 per occurrence such deductibles and/or retentions shall have the prior written consent of the County Risk Manager before the commencement of operations under this Agreement. Upon notification of deductibles or self insured retention's unacceptable to the County, and at the election of the Country's Risk Manager, Contractor's carriers shall either; 1) reduce or eliminate such deductibles or self-insured retention's as respects this Agreement with the County, or 2) procure a bond which guarantees payment of losses and related investigations, claims administration, and defense costs and expenses.

c) Contractor shall cause Contractor's insurance carrier(s) to furnish the County of Riverside with either 1) a properly executed original Certificate(s) of Insurance and certified original copies of Endorsements effecting coverage as required herein, or 2) if requested to do so orally or in writing by the County Risk Manager, provide original Certified copies of policies including all Endorsements and all attachments thereto, showing such insurance is in full force and effect. Further, said Certificate(s) and policies of insurance shall contain the covenant of the insurance carrier(s) that thirty (30) days written notice shall be given to the County of Riverside prior to any material modification, cancellation,

expiration or reduction in coverage of such insurance. In the event of a material modification, cancellation, expiration, or reduction in coverage, this Agreement shall terminate forthwith, unless the County of Riverside receives, prior to such effective date, another properly executed original Certificate of Insurance and original copies of endorsements or certified original policies, including all endorsements and attachments thereto evidencing coverage's set forth herein and the insurance required herein is in full force and effect. *Contractor shall not commence operations until the County has been furnished original Certificate (s) of Insurance and certified original copies of endorsements or policies of insurance including all endorsements and any and all other attachments as required in this Section. An individual authorized by the insurance carrier to do on its behalf shall sign the original endorsements for each policy and the Certificate of Insurance.*

d) It is understood and agreed to by the parties hereto and the insurance company(s), that the Certificate(s) of Insurance and policies shall so covenant and shall be construed as primary insurance, and the County's insurance and/or deductibles and/or self-insured retention's or self-insured programs shall not be construed as contributory.

e) The County's Reserved Rights--Insurance. If, during the term of this Agreement or any extension thereof, there is a material change in the scope of services; or, there is a material change in the equipment to be used in the performance of the scope of work (such as the use of aircraft or watercraft) the County reserves the right to adjust the types of insurance required under this Agreement and the monetary limits of liability for the insurance coverage's currently required herein, if; in the County Risk Manager's reasonable judgment, the amount or type of insurance carried by the Contractor has become inadequate.

f) Contractor shall pass down the insurance obligations contained herein to all tiers of subcontractors working under this Agreement. g) The insurance requirements contained in this agreement may be met with a program(s) of self-insurance acceptable to the County

A. APPLICABILITY

The Project or Program to which the construction work covered by this Contract pertains is being assisted by the United States of America, and the following Federal Labor Standards Provisions are included in this Contract pursuant to the provisions applicable to such Federal assistance.

1. Minimum wages and fringe benefits

i. All laborers and mechanics employed or working upon the site of the work (or otherwise working in construction or development of the project under a development statute), will be paid unconditionally and not less often than once a week, and without subsequent deduction or rebate on any account (except such payroll deductions as are permitted by regulations issued by the Secretary of Labor under the Copeland Act (29 CFR part 3)), the full amount of basic hourly wages and bona fide fringe benefits (or cash equivalents thereof) due at time of payment computed at rates not less than those contained in the wage determination of the Secretary of Labor which is attached hereto and made a part hereof, regardless of any contractual relationship which may be alleged to exist between the contractor and such laborers and mechanics. As provided in 29 CFR 5.5(d) and (e), the appropriate wage determinations are effective by operation of law even if they have not been attached to the contract. Contributions made or costs reasonably anticipated for bona fide fringe benefits under the Davis-Bacon Act (40 U.S.C. 3141(2)(B)) on behalf of laborers or mechanics are considered wages paid to such laborers or mechanics, subject to the provisions of paragraph (a)(1)(v) of these contract clauses; also, regular contributions made or costs incurred for more than a weekly period (but not less often than quarterly) under plans, funds, or programs which cover the particular weekly period, are deemed to be constructively made or incurred during such weekly period. Such laborers and mechanics must be paid the appropriate wage rate and fringe benefits on the wage determination for the classification(s) of work actually performed, without regard to skill, except as provided in 29 CFR 5.5(a)(4). Laborers or mechanics performing work in more than one classification may be compensated at the rate specified for each classification for the time actually worked therein: *Provided*, That the employer's payroll records accurately set forth the time spent in each classification in which work is performed. The wage determination (including any additional classifications and wage rates conformed under 29 CFR 5.5(a)(1)(iii)) and the Davis-Bacon poster (WH-1321) must be posted at all times by the contractor and its subcontractors at the site of the work in a prominent and accessible place where it can be easily seen by the workers.

ii. Frequently recurring classifications

A. In addition to wage and fringe benefit rates that have been determined to be prevailing under the procedures set forth in 29 CFR part 1, a wage determination may contain, pursuant to § 1.3(f), wage and fringe benefit rates for classifications of laborers and mechanics for which conformance requests are regularly submitted pursuant to 29 CFR 5.5(a)(1)(iii), provided that:

1. The work performed by the classification is not performed by a classification in the wage determination for which a prevailing wage rate has been determined;
2. The classification is used in the area by the construction industry; and
3. The wage rate for the classification bears a reasonable relationship to the prevailing wage rates contained in the wage determination.

B. The Administrator will establish wage rates for such classifications in accordance with 29 CFR 5.5(a)(1)(iii)(A)(3). Work performed in such a classification must be paid at no less than the wage and fringe benefit rate listed on the wage determination for such classification.

iii. Conformance

A. The contracting officer must require that any class of laborers or mechanics, including helpers, which is not listed in the wage determination and which is to be employed under the contract be classified in conformance with the wage determination. Conformance of an additional classification and wage rate

and fringe benefits is appropriate only when the following criteria have been met:

1. The work to be performed by the classification requested is not performed by a classification in the wage determination; and
 2. The classification is used in the area by the construction industry; and
 3. The proposed wage rate, including any bona fide fringe benefits, bears a reasonable relationship to the wage rates contained in the wage determination.
- B.** The conformance process may not be used to split, subdivide, or otherwise avoid application of classifications listed in the wage determination.
- C.** If the contractor and the laborers and mechanics to be employed in the classification (if known), or their representatives, and the contracting officer agree on the classification and wage rate (including the amount designated for fringe benefits where appropriate), a report of the action taken will be sent by the contracting officer by email to DBAconformance@dol.gov. The Administrator, or an authorized representative, will approve, modify, or disapprove every additional classification action within 30 days of receipt and so advise the contracting officer or will notify the contracting officer within the 30-day period that additional time is necessary.
- D.** In the event the contractor, the laborers or mechanics to be employed in the classification or their representatives, and the contracting officer do not agree on the proposed classification and wage rate (including the amount designated for fringe benefits, where appropriate), the contracting officer will, by email to DBAconformance@dol.gov, refer the questions, including the views of all interested parties and the recommendation of the contracting officer, to the Administrator for determination. The Administrator, or an authorized representative, will issue a determination within 30 days of receipt and so advise the contracting officer or will notify the contracting officer within the 30-day period that additional time is necessary.
- E.** The contracting officer must promptly notify the contractor of the action taken by the Wage and Hour Division under 29 CFR 5.5 (a)(1)(iii)(C) and (D). The contractor must furnish a written copy of such determination to each affected worker or it must be posted as a part of the wage determination. The wage rate (including fringe benefits where appropriate) determined pursuant to 29 CFR 5.5 (a)(1)(iii)(C) or (D) must be paid to all workers performing work in the classification under this contract from the first day on which work is performed in the classification.
- iv. Fringe benefits not expressed as an hourly rate**
Whenever the minimum wage rate prescribed in the contract for a class of laborers or mechanics includes a fringe benefit which is not expressed as an hourly rate, the contractor may either pay the benefit as stated in the wage determination or may pay another bona fide fringe benefit or an hourly cash equivalent thereof.
- v. Unfunded plans**
If the contractor does not make payments to a trustee or other third person, the contractor may consider as part of the wages of any laborer or mechanic the amount of any costs reasonably anticipated in providing bona fide fringe benefits under a plan or program, *Provided*, That the Secretary of Labor has found, upon the written request of the contractor, in accordance with the criteria set forth in 29 CFR 5.28, that the applicable standards of the Davis-Bacon Act have been met. The Secretary of Labor may require the contractor to set aside in a separate account assets for the meeting of obligations under the plan or program.
- vi. Interest** In the event of a failure to pay all or part of the wages required by the contract, the contractor will be required to pay interest on any underpayment of wages.

2. Withholding

i. Withholding requirements

The U. S. Department of Housing and Urban Development may, upon its own action, or must, upon written request of an authorized representative of the Department of Labor, withhold or cause to be withheld from the contractor so much of the accrued payments or advances as may be considered necessary to satisfy the liabilities of the prime contractor or any subcontractor for the full amount of wages and monetary relief, including interest, required by the clauses set forth in 29 CFR 5.5(a) for violations of this contract, or to satisfy any such liabilities required by any other Federal contract, or federally assisted contract subject to Davis-Bacon labor standards, that is held by the same prime contractor (as defined in 29 CFR 5.2). The necessary funds may be withheld from the contractor under this contract, any other Federal contract with the same prime contractor, or any other federally assisted contract that is subject to Davis-Bacon labor standards requirements and is held by the same prime contractor, regardless of whether the other contract was awarded or assisted by the same agency, and such funds may be used to satisfy the contractor liability for which the funds were withheld. In the event of a contractor's failure to pay any laborer or mechanic, including any apprentice or helper working on the site of the work (or otherwise working in construction or development of the project under a development statute) all or part of the wages required by the contract, or upon the contractor's failure to submit the required records as discussed in 29 CFR 5.5(a)(3)(iv), HUD may on its own initiative and after written notice to the contractor, sponsor, applicant, owner, or other entity, as the case may be, take such action as may be necessary to cause the suspension of any further payment, advance, or guarantee of funds until such violations have ceased.

ii. Priority to withheld funds

The Department has priority to funds withheld or to be withheld in accordance with 29 CFR 5.5(a)(2)(i) or (b)(3)(i), or both, over claims to those funds by:

- A. A contractor's surety(ies), including without limitation performance bond sureties and payment bond sureties;
- B. A contracting agency for its procurement costs;
- C. A trustee(s) (either a court-appointed trustee or a U.S. trustee, or both) in bankruptcy of a contractor, or a contractor's bankruptcy estate;
- D. A contractor's assignee(s);
- E. A contractor's successor(s); or
- F. A claim asserted under the Prompt Payment Act, 31 U.S.C. 3901-3907.

3. Records and certified payrolls

i. Basic record requirements

A. Length of record retention. All regular payrolls and other basic records must be maintained by the contractor and any subcontractor during the course of the work and preserved for all laborers and mechanics working at the site of the work (or otherwise working in construction or development of the project under a development statute) for a period of at least 3 years after all the work on the prime contract is completed.

B. Information required Such records must contain the name; Social Security number; last known address, telephone number, and email address of each such worker; each worker's correct classification(s) of work actually performed; hourly rates of wages paid (including rates of contributions or costs anticipated for bona fide fringe benefits or cash equivalents thereof of the types described in 40 U.S.C. 3141(2)(B) of the Davis-Bacon Act); daily and weekly number of hours actually worked in total and on each covered contract; deductions made; and actual wages paid.

C. Additional records relating to fringe benefits. Whenever the Secretary of Labor has found under 29 CFR 5.5(a)(1)(v) that the wages of any laborer or mechanic include the amount of any

costs reasonably anticipated in providing benefits under a plan or program described in 40 U.S.C. 3141(2)(B) of the Davis-Bacon Act, the contractor must maintain records which show that the commitment to provide such benefits is enforceable, that the plan or program is financially responsible, and that the plan or program has been communicated in writing to the laborers or mechanics affected, and records which show the costs anticipated or the actual cost incurred in providing such benefits.

D. Additional records relating to apprenticeship Contractors with apprentices working under approved programs must maintain written evidence of the registration of apprenticeship programs, the registration of the apprentices, and the ratios and wage rates prescribed in the applicable programs.

ii. Certified payroll requirements

A. Frequency and method of submission The contractor or subcontractor must submit weekly, for each week in which any DBA- or Related Acts-covered work is performed, certified payrolls to HUD if the agency is a party to the contract, but if the agency is not such a party, the contractor will submit the certified payrolls to the applicant, sponsor, owner, or other entity, as the case may be, that maintains such records, for transmission to HUD. The prime contractor is responsible for the submission of all certified payrolls by all subcontractors. A contracting agency or prime contractor may permit or require contractors to submit certified payrolls through an electronic system, as long as the electronic system requires a legally valid electronic signature; the system allows the contractor, the contracting agency, and the Department of Labor to access the certified payrolls upon request for at least 3 years after the work on the prime contract has been completed; and the contracting agency or prime contractor permits other methods of submission in situations where the contractor is unable or limited in its ability to use or access the electronic system

B. Information required The certified payrolls submitted must set out accurately and completely all of the information required to be maintained under 29 CFR 5.5(a)(3)(i)(B), except that full Social Security numbers and last known addresses, telephone numbers, and email addresses must not be included on weekly transmittals. Instead, the certified payrolls need only include an individually identifying number for each worker (*e.g.*, the last four digits of the worker's Social Security number). The required weekly certified payroll information may be submitted using Optional Form WH-347 or in any other format desired. Optional Form WH-347 is available for this purpose from the Wage and Hour Division Web site at <https://www.dol.gov/sites/dolgov/files/WHD/legacy/files/wh347.pdf> or its successor website. It is not a violation of this section for a prime contractor to require a subcontractor to provide full Social Security numbers and last known addresses, telephone numbers, and email addresses to the prime contractor for its own records, without weekly submission by the subcontractor to the sponsoring government agency (or the applicant, sponsor, owner, or other entity, as the case may be, that maintains such records).

C. Statement of Compliance Each certified payroll submitted must be accompanied by a "Statement of Compliance," signed by the contractor or subcontractor, or the contractor's or subcontractor's agent who pays or supervises the payment of the persons working on the contract, and must certify the following:

1. That the certified payroll for the payroll period contains the information required to be provided under 29 CFR 5.5(a)(3)(ii), the appropriate information and basic records are being maintained under 29 CFR 5.5 (a)(3)(i), and such information and records are correct and complete;
2. That each laborer or mechanic (including each helper and apprentice) working on the contract during the payroll period has been paid the full weekly wages earned, without

rebate, either directly or indirectly, and that no deductions have been made either directly or indirectly from the full wages earned, other than permissible deductions as set forth in 29 CFR part 3; and

3. That each laborer or mechanic has been paid not less than the applicable wage rates and fringe benefits or cash equivalents for the classification(s) of work actually performed, as specified in the applicable wage determination incorporated into the contract.
- D. Use of Optional Form WH-347** The weekly submission of a properly executed certification set forth on the reverse side of Optional Form WH-347 will satisfy the requirement for submission of the “Statement of Compliance” required by 29 CFR 5.5(a)(3)(ii)(C).
- E. Signature** The signature by the contractor, subcontractor, or the contractor’s or subcontractor’s agent must be an original handwritten signature or a legally valid electronic signature.
- F. Falsification** The falsification of any of the above certifications may subject the contractor or subcontractor to civil or criminal prosecution under 18 U.S.C. 1001 and 31 U.S.C. 3729.
- G. Length of certified payroll retention** The contractor or subcontractor must preserve all certified payrolls during the course of the work and for a period of 3 years after all the work on the prime contract is completed.
- iii. Contracts, subcontracts, and related documents** The contractor or subcontractor must maintain this contract or subcontract and related documents including, without limitation, bids, proposals, amendments, modifications, and extensions. The contractor or subcontractor must preserve these contracts, subcontracts, and related documents during the course of the work and for a period of 3 years after all the work on the prime contract is completed.
- iv. Required disclosures and access**
- A. Required record disclosures and access to workers** The contractor or subcontractor must make the records required under 29 CFR 5.5(a)(3)(i)–(iii), and any other documents that HUD or the Department of Labor deems necessary to determine compliance with the labor standards provisions of any of the applicable statutes referenced by 29 CFR 5.1, available for inspection, copying, or transcription by authorized representatives of HUD or the Department of Labor, and must permit such representatives to interview workers during working hours on the job.
- B. Sanctions for non-compliance with records and worker access requirements** If the contractor or subcontractor fails to submit the required records or to make them available, or refuses to permit worker interviews during working hours on the job, the Federal agency may, after written notice to the contractor, sponsor, applicant, owner, or other entity, as the case may be, that maintains such records or that employs such workers, take such action as may be necessary to cause the suspension of any further payment, advance, or guarantee of funds. Furthermore, failure to submit the required records upon request or to make such records available, or to permit worker interviews during working hours on the job, may be grounds for debarment action pursuant to 29 CFR 5.12. In addition, any contractor or other person that fails to submit the required records or make those records available to WHD within the time WHD requests that the records be produced will be precluded from introducing as evidence in an administrative proceeding under 29 CFR part 6 any of the required records that were not provided or made available to WHD. WHD will take into consideration a reasonable request from the contractor or person for an extension of the time for submission of records. WHD will determine the reasonableness of the request and may consider, among other things, the location of the records and the volume of production.

- C. **Required information disclosures** Contractors and subcontractors must maintain the full Social Security number and last known address, telephone number, and email address of each covered worker, and must provide them upon request to HUD if the agency is a party to the contract, or to the Wage and Hour Division of the Department of Labor. If the Federal agency is not such a party to the contract, the contractor, subcontractor, or both, must, upon request, provide the full Social Security number and last known address, telephone number, and email address of each covered worker to the applicant, sponsor, owner, or other entity, as the case may be, that maintains such records, for transmission to HUD, the contractor, or the Wage and Hour Division of the Department of Labor for purposes of an investigation or other compliance action.

4. Apprentices and equal employment opportunity

i. Apprentices

- A. **Rate of pay** Apprentices will be permitted to work at less than the predetermined rate for the work they perform when they are employed pursuant to and individually registered in a bona fide apprenticeship program registered with the U.S. Department of Labor, Employment and Training Administration, Office of Apprenticeship (OA), or with a State Apprenticeship Agency recognized by the OA. A person who is not individually registered in the program, but who has been certified by the OA or a State Apprenticeship Agency (where appropriate) to be eligible for probationary employment as an apprentice, will be permitted to work at less than the predetermined rate for the work they perform in the first 90 days of probationary employment as an apprentice in such a program. In the event the OA or a State Apprenticeship Agency recognized by the OA withdraws approval of an apprenticeship program, the contractor will no longer be permitted to use apprentices at less than the applicable predetermined rate for the work performed until an acceptable program is approved.
- B. **Fringe benefits** Apprentices must be paid fringe benefits in accordance with the provisions of the apprenticeship program. If the apprenticeship program does not specify fringe benefits, apprentices must be paid the full amount of fringe benefits listed on the wage determination for the applicable classification. If the Administrator determines that a different practice prevails for the applicable apprentice classification, fringe benefits must be paid in accordance with that determination.
- C. **Apprenticeship ratio** The allowable ratio of apprentices to journeyworkers on the job site in any craft classification must not be greater than the ratio permitted to the contractor as to the entire work force under the registered program or the ratio applicable to the locality of the project pursuant to 29 CFR 5.5(a)(4)(i)(D). Any worker listed on a payroll at an apprentice wage rate, who is not registered or otherwise employed as stated in 29 CFR 5.5(a)(4)(i)(A), must be paid not less than the applicable wage rate on the wage determination for the classification of work actually performed. In addition, any apprentice performing work on the job site in excess of the ratio permitted under this section must be paid not less than the applicable wage rate on the wage determination for the work actually performed.
- D. **Reciprocity of ratios and wage rates** Where a contractor is performing construction on a project in a locality other than the locality in which its program is registered, the ratios and wage rates (expressed in percentages of the journey worker's hourly rate) applicable within the locality in which the construction is being performed must be observed. If there is no applicable ratio or wage rate for the locality of the project, the ratio and wage rate specified in the contractor's registered program must be observed.

ii. Equal employment opportunity The use of apprentices and journey workers under this part

must be in conformity with the equal employment opportunity requirements of Executive Order 11246, as amended, and 29 CFR part 30.

5. **Compliance with Copeland Act requirements.** The contractor shall comply with the requirements of 29 CFR part 3, which are incorporated by reference in this contract.
6. **Subcontracts.** The contractor or subcontractor must insert in any subcontracts the clauses contained in 29 CFR 5.5(a)(1) through (11), along with the applicable wage determination(s) and such other clauses or contract modifications as the U.S. Department of Housing and Urban Development may by appropriate instructions require, and a clause requiring the subcontractors to include these clauses and wage determination(s) in any lower tier subcontracts. The prime contractor is responsible for the compliance by any subcontractor or lower tier subcontractor with all the contract clauses in this section. In the event of any violations of these clauses, the prime contractor and any subcontractor(s) responsible will be liable for any unpaid wages and monetary relief, including interest from the date of the underpayment or loss, due to any workers of lower-tier subcontractors, and may be subject to debarment, as appropriate.
7. **Contract termination: debarment.** A breach of the contract clauses in 29 CFR 5.5 may be grounds for termination of the contract, and for debarment as a contractor and a subcontractor as provided in 29 CFR 5.12.
8. **Compliance with Davis-Bacon and Related Act requirements.** All rulings and interpretations of the Davis-Bacon and Related Acts contained in 29 CFR parts 1, 3, and 5 are herein incorporated by reference in this contract.
9. **Disputes concerning labor standards.** Disputes arising out of the labor standards provisions of this contract shall not be subject to the general disputes clause of this contract. Such disputes shall be resolved in accordance with the procedures of the Department of Labor set forth in 29 CFR parts 5, 6, and 7. Disputes within the meaning of this clause include disputes between the contractor (or any of its subcontractors) and the contracting agency, the U.S. Department of Labor, or the employees or their representatives.
10. **Certification of eligibility.**
 - i. By entering into this contract, the contractor certifies that neither it nor any person or firm who has an interest in the contractor's firm is a person or firm ineligible to be awarded Government contracts by virtue of 40 U.S.C. 3144(b) or 29 CFR 5.12(a).
 - ii. No part of this contract shall be subcontracted to any person or firm ineligible for award of a Government contract by virtue of 40 U.S.C. 3144(b) or 29 CFR 5.12(a).
 - iii. The penalty for making false statements is prescribed in the U.S. Code, Title 18 Crimes and Criminal Procedure, 18 U.S.C. 1001.
11. **Anti-retaliation** It is unlawful for any person to discharge, demote, intimidate, threaten, restrain, coerce, blacklist, harass, or in any other manner discriminate against, or to cause any person to discharge, demote, intimidate, threaten, restrain, coerce, blacklist, harass, or in any other manner discriminate against, any worker or job applicant for:
 - i. Notifying any contractor of any conduct which the worker reasonably believes constitutes a violation of the DBA, Related Acts, or 29 CFR parts 1, 3, or 5;
 - ii. Filing any complaint, initiating or causing to be initiated any proceeding, or otherwise asserting or seeking to assert on behalf of themselves or others any right or protection under the DBA, Related Acts, or 29 CFR parts 1, 3, or 5;
 - iii. Cooperating in any investigation or other compliance action, or testifying in any proceeding under the DBA, Related Acts, or 29 CFR parts 1, 3, or 5; or
 - iv. Informing any other person about their rights under the DBA, Related Acts, or 29 CFR parts 1, 3, or 5.

B. Contract Work Hours and Safety Standards Act (CWHSSA)

The Agency Head must cause or require the contracting officer to insert the following clauses set forth in 29 CFR 5.5(b)(1), (2), (3), (4), and (5) in full, or (for contracts covered by the Federal Acquisition Regulation) by reference, in any contract in an amount in excess of \$100,000 and subject to the overtime provisions of the Contract Work Hours and Safety Standards Act. These clauses must be inserted in addition to the clauses required by 29 CFR 5.5(a) or 4.6. As used in this paragraph, the terms “laborers and mechanics” include watchpersons and guards.

- 1. Overtime requirements.** No contractor or subcontractor contracting for any part of the contract work which may require or involve the employment of laborers or mechanics shall require or permit any such laborer or mechanic in any workweek in which he or she is employed on such work to work in excess of forty hours in such workweek unless such laborer or mechanic receives compensation at a rate not less than one and one-half times the basic rate of pay for all hours worked in excess of forty hours in such workweek.
- 2. Violation; liability for unpaid wages; liquidated damages.** In the event of any violation of the clause set forth in 29 CFR 5.5(b)(1) the contractor and any subcontractor responsible therefor shall be liable for the unpaid wages and interest from the date of the underpayment. In addition, such contractor and subcontractor shall be liable to the United States (in the case of work done under contract for the District of Columbia or a territory, to such District or to such territory), for liquidated damages. Such liquidated damages shall be computed with respect to each individual laborer or mechanic, including watchpersons and guards, employed in violation of the clause set forth in 29 CFR 5.5(b)(1), in the sum of \$31 for each calendar day on which such individual was required or permitted to work in excess of the standard workweek of forty hours without payment of the overtime wages required by the clause set forth in 29 CFR 5.5(b)(1).
- 3. Withholding for unpaid wages and liquidated damages**
 - i. Withholding process** The U.S Department of Housing and Urban Development or the recipient of Federal assistance may, upon its own action, or must, upon written request of an authorized representative of the Department of Labor, withhold or cause to be withheld from the contractor so much of the accrued payments or advances as may be considered necessary to satisfy the liabilities of the prime contractor or any subcontractor for any unpaid wages; monetary relief, including interest; and liquidated damages required by the clauses set forth in 29 CFR 5.5(b) on this contract, any other Federal contract with the same prime contractor, or any other federally assisted contract subject to the Contract Work Hours and Safety Standards Act that is held by the same prime contractor (as defined in 29 CFR 5.2). The necessary funds may be withheld from the contractor under this contract, any other Federal contract with the same prime contractor, or any other federally assisted contract that is subject to the Contract Work Hours and Safety Standards Act and is held by the same prime contractor, regardless of whether the other contract was awarded or assisted by the same agency, and such funds may be used to satisfy the contractor liability for which the funds were withheld.
 - ii Priority to withheld funds** The Department has priority to funds withheld or to be withheld in accordance with 29 CFR 5.5(a)(2)(i) or (b)(3)(i), or both, over claims to those funds by:
 - A.** A contractor’s surety(ies), including without limitation performance bond sureties and payment bond sureties;
 - B.** A contracting agency for its procurement costs;
 - C.** A trustee(s) (either a court-appointed trustee or a U.S. trustee, or both) in bankruptcy of a contractor, or a contractor’s bankruptcy estate;
 - D.** A contractor’s assignee(s);
 - E.** A contractor’s successor(s); or

- F. A claim asserted under the Prompt Payment Act, 31 U.S.C. 3901-3907.
4. **Subcontracts.** The contractor or subcontractor must insert in any subcontracts the clauses set forth in 29 CFR 5.5(b)(1) through (5) and a clause requiring the subcontractors to include these clauses in any lower tier subcontracts. The prime contractor is responsible for compliance by any subcontractor or lower tier subcontractor with the clauses set forth in 29 CFR 5.5(b)(1) through (5). In the event of any violations of these clauses, the prime contractor and any subcontractor(s) responsible will be liable for any unpaid wages and monetary relief, including interest from the date of the underpayment or loss, due to any workers of lower-tier subcontractors, and associated liquidated damages and may be subject to debarment, as appropriate.
- 5 **Anti-retaliation** It is unlawful for any person to discharge, demote, intimidate, threaten, restrain, coerce, blacklist, harass, or in any other manner discriminate against, or to cause any person to discharge, demote, intimidate, threaten, restrain, coerce, blacklist, harass, or in any other manner discriminate against, any worker or job applicant for:
- i. Notifying any contractor of any conduct which the worker reasonably believes constitutes a violation of the Contract Work Hours and Safety Standards Act (CWHSSA) or its implementing regulations in 29 CFR part 5;
 - ii. Filing any complaint, initiating or causing to be initiated any proceeding, or otherwise asserting or seeking to assert on behalf of themselves or others any right or protection under CWHSSA or 29 CFR part 5;
 - iii. Cooperating in any investigation or other compliance action, or testifying in any proceeding under CWHSSA or 29 CFR part 5; or
 - iv. Informing any other person about their rights under CWHSSA or 29 CFR part 5.
- C. **CWHSSA required records clause** In addition to the clauses contained in 29 CFR 5.5(b), in any contract subject only to the Contract Work Hours and Safety Standards Act and not to any of the other laws referenced by 29 CFR 5.1, the Agency Head must cause or require the contracting officer to insert a clause requiring that the contractor or subcontractor must maintain regular payrolls and other basic records during the course of the work and must preserve them for a period of 3 years after all the work on the prime contract is completed for all laborers and mechanics, including guards and watchpersons, working on the contract. Such records must contain the name; last known address, telephone number, and email address; and social security number of each such worker; each worker's correct classification(s) of work actually performed; hourly rates of wages paid; daily and weekly number of hours actually worked; deductions made and actual wages paid. Further, the Agency Head must cause or require the contracting officer to insert in any such contract a clause providing that the records to be maintained under this paragraph must be made available by the contractor or subcontractor for inspection, copying, or transcription by authorized representatives of the (write the name of agency) and the Department of Labor, and the contractor or subcontractor will permit such representatives to interview workers during working hours on the job.
- D. **Incorporation of contract clauses and wage determinations by reference** Although agencies are required to insert the contract clauses set forth in this section, along with appropriate wage determinations, in full into covered contracts, and contractors and subcontractors are required to insert them in any lower-tier subcontracts, the incorporation by reference of the required contract clauses and appropriate wage determinations will be given the same force and effect as if they were inserted in full text.
- E. **Incorporation by operation of law** The contract clauses set forth in this section (or their equivalent under the Federal Acquisition Regulation), along with the correct wage determinations, will be considered to be a part of every prime contract required by the applicable statutes referenced by 29 CFR 5.1 to include such clauses, and will be effective by

operation of law, whether or not they are included or incorporated by reference into such contract, unless the Administrator grants a variance, tolerance, or exemption from the application of this paragraph. Where the clauses and applicable wage determinations are effective by operation of law under this paragraph, the prime contractor must be compensated for any resulting increase in wages in accordance with applicable law.

F. HEALTH AND SAFETY

The provisions of this paragraph (F) are applicable where the amount of the prime contract exceeds

\$100,000.

1. No laborer or mechanic shall be required to work in surroundings or under working conditions which are unsanitary, hazardous, or dangerous to his or her health and safety, as determined under construction safety and health standards promulgated by the Secretary of Labor by regulation.
2. The contractor shall comply with all regulations issued by the Secretary of Labor pursuant to 29 CFR Part 1926 and failure to comply may result in imposition of sanctions pursuant to the Contract Work Hours and Safety Standards Act, (Public Law 91-54, 83 Stat 96), 40 U.S.C. § 3701 et seq.
3. The contractor shall include the provisions of this paragraph in every subcontract, so that such provisions will be binding on each subcontractor. The contractor shall take such action with respect to any subcontractor as the Secretary of Housing and Urban Development or the Secretary of Labor shall direct as a means of enforcing such provisions.

FEDERAL PREVAILING WAGE DECISION

(CA _____ mod. _____)
Insert most recent, (10 days prior to bid opening) wage decision at this point.

LABOR STANDARDS REQUIREMENTS - PRECONSTRUCTION PHASE. A construction project covered by Federal Labor Standards Provisions (HUD-4010) requires a series of specific actions prior to the actual start of construction. Those actions are:

- a. obtaining an applicable Davis-Bacon wage determination for the project;
- b. including that wage determination (and any modifications) in the bid documents where there is competitive bidding or in invitations for proposals; and
- c. including appropriate labor standards provisions and the wage determination in the construction contract.

CONSTRUCTION WAGE DETERMINATION - DEFINITION. All construction bid documents and contracts, or analogous instruments covered by the Federal Labor Standards Provisions (HUD-4010) must contain a current and applicable wage determination issued by the Department of Labor. The term “wage determination” includes the original decision and any subsequent decisions modifying, superseding, correcting, or otherwise changing the provisions of the original decision.

Reference: Handbook 1344.1 Federal Labor Standards Compliance in Housing and Community Development Programs'; paragraph 2-1, section 1 paragraph 1-1.

OBTAINING WAGE DETERMINATIONS

The Riverside County Department of Housing & Workforce Solutions (HWS) will be responsible to obtain and provide the appropriate Federal wage determination from the U.S. Department of Labor (DOL) for this project. The appropriate wage determination will be the most current determination, applicable for Riverside County and the construction type, that is effective ten (10) days before the opening of bids. Wage determinations shall be effective (locked-in) on the date that bids are opened provided that the contract is awarded within 90 days after bid opening. If the contract is awarded more than 90 days after bid opening, the wage determination shall be updated as of the date of award. If construction starts more than 90 days after contract award, the wage determination shall be updated as of the construction start date.

SEE APPENDIX B FOR PREVAILING
WAGE DETERMINATION

PROJECT SIGN

(For Community Development Block Grant Funded Projects)

Required for all Projects \$25,000 or over

(4' X 8')

[Contact HWS for City CDBG Funded Project]

**COUNTY OF RIVERSIDE
DEPARTMENT OF HOUSING & WORKFORCE SOLUTIONS**

SUPERVISOR (Enter First and Last Name)

(Enter District #1-5) DISTRICT



(Enter Project Name)

\$000,000.00

City of XXXXXXXX

(Mayor)

(City Manager)

*Figure 1 Change to your
City's Logo*



**(NAME)
CONTRACTOR**

**(NAME)
ENGINEER/ARCHITECT**

**FUNDED BY: U.S. DEPARTMENT OF HOUSING AND URBAN DEVELOPMENT
COMMUNITY DEVELOPMENT BLOCK GRANT PROGRAM
EQUAL OPPORTUNITY - AFFIRMATIVE ACTION EMPLOYER
EXECUTIVE ORDER 11246 AND SECTION 3 OF HOUSING AND URBAN
DEVELOPMENT ACT OF 1968, AS AMENDED**

Additional Federal Requirements

Whereas, the work under this Agreement is subject to applicable Federal, State, and local laws and regulations, including but not limited to the regulations pertaining to the Community Development Block Grant program (24 CFR *Part 570*) and the Uniform Administrative Requirement, Cost Principles, and Audit Requirements for Federal Awards (2 CFR *Part 200*). Contractor, sub-contractors, Consultants, and sub-consultants agree to comply with, and are subject to, all applicable requirements as follows:

1. **Equal Employment Opportunity** - Compliance with Executive Order 11246 of September 24, 1965, entitled "Equal Employment Opportunity", as amended by Executive Order 11375 of October 13, 1967, and as supplemented in Department of Labor regulations (41 CFR Part 60). The Contractor/Consultant will not discriminate against any employee or applicant for employment because of race, color, religion, sex, sexual orientation, general identity or national origin. Contractor/Consultant will ensure that all qualified applicants will receive consideration for employment without regard to race, color, religion, sex sexual orientation, general identity or national origin. The Contractor/Consultant will take affirmative action to ensure that applicants are employed and the employees are treated during employment, without regard to their race color, religion, sex, sexual orientation, general identity or national origin. Such actions shall include, but are not limited to, the following: employment, up-grading, demotion, or transfer; recruitment or recruitment advertising; rates of pay or other forms of compensation; and selection for training, including apprenticeship. The Contractor/Consultant agrees to post in a conspicuous place, available to employees and applicants for employment, notices to be provided by the County setting forth the provisions of this non-discriminating clause.

2. **Copeland "Anti-Kickback" Act** (18 U.S.C. 874 and 40 U.S.C.A. Section 3145): All contracts and subgrants in excess of \$2,000 for construction or repair awarded by recipients and subrecipients shall include a provision for compliance with the Copeland "Anti-Kickback" Act (18 U.S.C. 874), as supplemented by Department of Labor regulations (29 CFR Part 3, "Contractors and Subcontractors on Public Building or Public Work Financed in Whole or in Part by Loans or Grants from the United States"). The Act provides that each contractor or subrecipient shall be prohibited from inducing, by any means, any person employed in the construction, completion, or repair of public work, to give up any part of the compensation to which he is otherwise entitled. The recipient shall report all suspected or reported violations to HUD.

3. **Davis-Bacon Act, as amended** (40 U.S.C.A. Section 3141-3148): When required by Federal program legislation, all construction contracts awarded by the recipients and subrecipients of more than \$2000 shall include a provision for compliance with the Davis-Bacon Act (40 U.S.C. A. Section 3141-3148) and as supplemented by Department of Labor regulations (29 CFR Part 5, "Labor Standards Provisions Applicable to Contracts Governing Federally Financed and Assisted Construction"). Under the Davis Bacon Act, contractors shall be required to pay wages to laborers and mechanics at a rate not less than the minimum wages specified in a wage determination made by the U.S. Secretary of Labor. In addition, contractors shall be required to pay wages not less than once a week. The recipient shall place a copy of the current prevailing wage determination issued by the U.S. Department of Labor in each solicitation and the award of a contract shall be conditioned upon the acceptance of the wage determination. The recipient shall report all suspected or reported violations to HUD.

4. **Contract Work Hours and Safety Standards Act** (40 U.S.C.A.. 32701 through 3708): Where applicable, all contracts awarded by recipients in excess of \$2,000 for construction contracts and in excess of \$2,500 for other contracts that involve the employment of mechanics or laborers shall include a provision for compliance with the Contract Work Hours and Safety Standards (40 U.S.C.A. 32701-3708), as supplemented by Department of Labor Regulations (29 CFR Part 5). Under Section 40 U.S.C.A. 3702, each contractor shall be required to compute the wages of every mechanic and laborer on the basis of a standard workweek of 40 hours. Work in excess of the standard workweek is permissible provided that the worker is compensated at a rate of not less than 1 1/2 times the basic rate of pay for all hours worked in excess of

40 hours in the workweek. 40 U.S.C.A. 3704 of the Act is applicable to construction work and provides that no laborer or mechanic shall be required to work in surroundings or under working conditions which are unsanitary, hazardous or dangerous. These requirements do not apply to the purchases of supplies or materials or articles ordinarily available on the open market, or contracts for transportation or transmission of intelligence.

5. **Rights to Inventions Made Under a Contract or Agreement**— Contracts or agreements for the performance of experimental, developmental, or research work shall provide for the rights of the Federal Government and the recipient in any resulting invention in accordance with 37 CFR part 401, “Rights to Inventions Made by Nonprofit Organizations and Small Business Firms Under Government Grants, Contracts and Cooperative Agreements,” and any implementing regulations issued by HUD.

6. **Rights to Data and Copyrights** – Contractors and consultants agree to comply with all applicable provisions pertaining to the use of data and copyrights pursuant to 48 CFR Part 27.404-3, Federal Acquisition Regulations (FAR).

7. **Air Pollution Prevention and Control (formally known as the Clean Air Act) (42 U.S.C.A. 7401 et seq.) and the Federal Water Pollution Control Act (33 U.S.C.A. Section 1251 et seq.), as amended:**— Contracts and subgrants of amounts in excess of \$100,000 shall contain a provision that requires the recipient to agree to comply with all applicable standards, orders or regulations issued pursuant to the Clean Air Act (42 U.S.C. 7401 et seq.) and the Federal Water Pollution Control Act as amended (33 U.S.C.A. 1251 et seq.). Violations shall be reported to HUD and the Regional Office of the Environmental Protection Agency (EPA).

8. **Byrd Anti-Lobbying Amendment (31 U.S.C.A. 1352)**— Contractors who apply or bid for an award of \$100,000 or more shall file the required certification. Each tier certifies to the tier above that it will not and has not used Federal appropriated funds to pay any person or organization for influencing or attempting to influence an officer or employee of any agency, a member of Congress, officer or employee of Congress, or an employee of a member of Congress in connection with obtaining any Federal contract, grant or any other award covered by 31 U.S.C. 1352. Each tier shall also disclose any lobbying with non-Federal funds that takes place in connection with obtaining any Federal award. Such disclosures are forwarded from tier to tier up to the recipient.

9. **Debarment and Suspension (Executive Orders (E.O. s) 12549 and 12689)**—No contract shall be made to parties listed on the General Services Administration's List of Parties Excluded from Federal Procurement or Nonprocurement Programs in accordance with E.O.s 12549 and 12689, “Debarment and Suspension,” as set forth at 24 CFR part 2424. This list contains the names of parties debarred, suspended, or otherwise excluded by agencies, and contractors declared ineligible under statutory or regulatory authority other than E.O. 12549. Contractors with awards that exceed the small purchase threshold shall provide the required certification regarding its exclusion status and that of its principal employees.

10. **Drug-Free Workplace Requirements**— The Anti-Drug Abuse Act of 1988 (41 U.S.C.A. Section 8101-8103) requires grantees (including individuals) of federal agencies, as a prior condition of being awarded a grant, to certify that they will provide drug-free workplaces. Each potential recipient must certify that it will comply with drug-free workplace requirements in accordance with the Act and with HUD's rules at 24 CFR part 2425.

11. **Access to Records and Records Retention:** The Consultant or Contractor, and any sub-consultants or sub-contractors, shall allow all duly authorized Federal, State, and/or County officials or authorized representatives access to the work area, as well as all books, documents, materials, papers, and records of the Consultant or Contractor, and any sub-consultants or sub-contractors, that are directly pertinent to a specific program for the purpose of making audits, examinations, excerpts, and transcriptions. The Consultant or Contractor, and any sub-consultants or sub-contractors, further agree to maintain and keep

such books, documents, materials, papers, and records, on a current basis, recording all transactions pertaining to this agreement in a form in accordance with generally acceptable accounting principles. All such books and records shall be retained for such periods of time as required by law, provided, however, notwithstanding any shorter periods of retention, all books, records, and supporting detail shall be retained for a period of at least four (4) years after the expiration of the term of this Agreement.

12. **Federal Employee Benefit Clause:** No member of or delegate to the congress of the United States, and no Resident Commissioner shall be admitted to any share or part of this agreement or to any benefit to arise from the same.

13. **Energy Efficiency:** Mandatory standards and policies relating to energy efficiency which are contained in the State energy conservation plan issued in compliance with the Energy Policy and Conservation Act (Pub. L. 94A 163, Dec. 22, 1975; 42 U.S.C.A. Section 6201, et. seq., 89 Stat. 871).

14. **Procurement of Recovered Materials (2 CFR 200.322.)** A non-Federal entity that is a state agency or agency of a political subdivision of a state and its contractors must comply with 42 U.S.C. Section 6962 of the Solid Waste Disposal Act (42 U.S.C.A. Section 6901, et seq.), as amended by the Resource Conservation and Recovery Act. The requirements of Section 6002 include procuring only items designated in guidelines of the Environmental Protection Agency (EPA) at 40 CFR part 247 that contain the highest percentage of recovered materials practicable, consistent with maintaining a satisfactory level of competition, where the purchase price of the item exceeds \$10,000 or the value of the quantity acquired by the preceding fiscal year exceeded \$10,000; procuring solid waste management services in a manner that maximizes energy and resource recovery; and establishing an affirmative procurement program for procurement of recovered materials identified in the EPA guidelines.

15. **Build America, Buy America (BABA) Act:** The Grantee must comply with the requirements of the Build America, Buy America (BABA) Act, 41 USC 8301 note, and all applicable rules and notices, as may be amended, if applicable to the Grantee's infrastructure project. Pursuant to HUD's Notice, "Public Interest Phased Implementation Waiver for FY 2022 and 2023 of Build America, Buy America Provisions as Applied to Recipients of HUD Federal Financial Assistance" (88 FR 17001), any funds obligated by HUD on or after the applicable listed effective dates, are subject to BABA requirements, unless excepted by a waiver.

16. **Violence Against Women Act (VAWA):** VAWA provides housing protections for survivors of domestic and dating violence, sexual assault and stalking ('domestic violence'). VAWA 2022 reauthorizes, amends, and strengthens the VAWA of 1994, as amended (Pub. L. 103-322, tit. IV, sec. 40001-40703; 34 U.S.C. 12291 et seq.) HUD's implementing regulations for VAWA'S protections, rights, and responsibilities are codified in 24 CFR part 5, subpart L, and related provisions in HUD's program regulations (HUD's VAWA regulations). VAWA 2022 amendments took effect on October 1, 2022 and 2022 VAWA's reauthorization includes new implementation requirements. Grantees, subrecipients and developers shall ensure compliance with all requirements of VAWA including but not limited to: (a) Assure domestic violence survivors are not denied assistance as an applicant, or evicted, or have assistance terminated as a tenant because applicant or tenant is or has been a victim of domestic violence; (b) Implement an emergency transfer plan allowing domestic violence survivor to move to another safe and available unit; (c) Provide protections against denial, terminations, and evictions that directly result from being a victim of domestic violence; (d) Implement a low barrier certification process and allow self-certification of domestic violence.

**CERTIFICATION OF BIDDER
REGARDING NONSEGREGATED FACILITIES**

Project Name: _____

Name of Bidder: _____

The above-named Bidder hereby certifies that:

I do not maintain or provide for my employees any segregated facilities at any of my establishments, and that I do not permit my employees to perform their services at any location, under my control, where segregated facilities are maintained. As used in this certification, the term "segregated facilities" means any waiting rooms, work areas, rest rooms, wash rooms, restaurants and other eating areas, time clocks, locker rooms or other dressing areas, parking lots, drinking fountains, recreation or entertainment areas, transportation, and housing facilities provided for employees which are segregated by explicit directive or are in fact segregated on the basis of race, color, religion, national origin, or because of habits, local customs, or otherwise.

I further agree to obtain identical certifications from all proposed subcontractors prior to the award of subcontracts exceeding \$10,000.

Signature: _____

Name (Print): _____

Title: _____

Date: _____



**COUNTY OF RIVERSIDE'S
DEPARTMENT OF HOUSING AND WORKFORCE SOLUTIONS
SECTION 3 PROGRAM
OVERVIEW AND REQUIREMENTS**

The work to be performed under this contract is subject to the requirements of section 3 of the Housing and Urban Development Act of 1968, as amended, 12 U.S.C. 1701u (section 3). The purpose of section 3 is to ensure that employment and other economic opportunities generated by HUD assistance or HUD-assisted projects covered by section 3, shall, to the greatest extent feasible, be directed to low- and very low-income persons, particularly persons who are recipients of HUD assistance for housing or residents of the community in which Federal assistance is spent.

APPLICABILITY

- Recipients and sub-recipients of Section 3 covered assistance, including contractors and subcontractors that perform work on Section 3 covered contracts/projects, are required to comply with Section 3 requirements.
- Section 3 requirements do not apply to contractors who furnish only materials or supplies and do not undertake the installation of the materials or supplies.

SECTION 3 GOALS

Contracts over \$200,000 trigger Section 3. When triggered, best efforts must be made to extend Section 3 opportunities to verified Section 3 residents and business concerns to meet these safe harbor benchmarks:

1. Twenty-five percent (25%) of the total hours on a Section 3 project must be worked by Section 3 workers; and
2. Five percent (5%) of the total hours on a Section 3 project must be worked by Targeted Section 3 workers.

Contractors and subcontractors must make their best efforts to provide employment and training opportunities to Section 3 Workers and document such efforts to realize the Section 3 benchmarks. Contractors and subcontractors will be considered to have complied with Section 3, if they meet or exceed the Section 3 benchmarks, or certify that they have followed the prioritization of efforts in 24 CFR 75.9 and 24 CFR 75.19.

SECTION 3 REQUIREMENTS FOR BIDDERS/PROPOSERS

Section 3 Project Implementation Plan

- I. Submittal of Section 3 Implementation Plan:
Bidder/Proposer AND its first-tier subcontractors are to submit a completed Section 3 Implementation Plan in bid. **A “non-responsive” determination may be made due to non-submittal.**
- II. Submittal of Supporting Documentation:
Bidder/Proposer AND its first-tier subcontractors whose Utilization Plans indicate no subcontract awards to certified Section 3 Business Concerns will be required to submit, upon request by HWS supporting documentation for review and approval verifying efforts to outreach to and award subcontracts to Section 3 Business Concerns. **A “non-responsive” determination shall be made due to a lack of documented outreach to Section 3 Business Concerns by the Bidder/Proposer.**

Bidder/Proposer may be deemed “non-responsive” if Implementation Plan indicates the following: (1) Existing employees do not meet the definition of a Section 3 Worker; and (2) Bidder/Proposer does not agree to make a documented good faith effort to hire Section 3 Workers (when there is a need to hire new employees).

SECTION 3 REQUIREMENTS FOR AWARDEES

Section 3 Contract Language

All Section 3 covered contracts and subcontracts shall include the following language:

- I. The work to be performed under this contract is subject to the requirements of Section 3 of the Housing and Urban Development Act of 1968, as amended, 12 USC.1701u (Section 3). The purpose of Section 3 is to ensure that employment and other economic opportunities generated by HUD assistance, or HUD-assisted projects covered by Section 3, shall to the greatest extent feasible be directed to low and very low-income persons, particularly persons who are recipients of HUD assistance for housing.
- II. The parties to this contract agree to comply with HUD's regulations in 24 CFR part 75, which implement Section 3. As evidenced by their execution of this contract, the parties to this contract certify that they are under no contractual or other impediment that would prevent them from complying with the part 75 regulations.
- III. The contractor agrees to send to each labor organization or representative of workers with which the contractor has a collective bargaining agreement or other understanding, if any, a notice advising the labor organization or workers' representative of the contractor's commitments under this Section 3 Clause and will post copies of the notice in conspicuous places at the work site where both employees and applicants for training and employment positions can see the notice. The notice shall describe the Section 3 preference, shall set forth minimum number and job titles subject to hire, availability of apprenticeship and training positions, the qualifications for each; the name and location of the person(s) taking applications for each of the positions; and the anticipated date the work shall begin.
- IV. The contractor agrees to include this Section 3 Clause in every subcontract subject to compliance with regulations in 24 CFR part 75, and agrees to take appropriate actions, as provided in an applicable provision of the subcontract or in this Section 3 Clause, upon a finding that the subcontractor is in violation of the regulations in 24 CFR part 75. The contractor will not subcontract with any subcontractor where the contractor has notice or knowledge that the subcontractor has been found in violation of the regulations in 24 CFR part 75.
- V. The contractor will certify that any vacant employment positions, including training positions, that are filled (1) after the contractor is selected but before the contract is executed, and (2) with persons other than those to whom the regulations of 24 CFR part 75 require employment opportunities to be directed, were not filled to circumvent the contractor's obligations under 24 CFR part 75.
- VI. Noncompliance with HUD's regulations in 24 CFR part 75 may result in sanctions, termination of this contract for default, and debarment or suspension from future HUD assisted contracts.
- VII. With respect to work performed in connection with Section 3 covered Indian housing assistance, section 7(b) of the Indian Self-Determination and Education Assistance Act (25 USC 450e) also applies to the work to be performed under this contract. Section 7(b) requires that to the greatest extent feasible (i) preference and opportunities for training and employment shall be given to Indians and (ii) preference in the award of contracts and subcontracts shall be given to Indian organizations and Indian-owned Economic Enterprises. Parties to this contract that are subject to the provisions of Section 3 and section 7(b) agree to comply with Section 3 to the maximum extent feasible, but not in derogation of compliance with section 7(b).

Section 3 Quarterly Labor Hours Report

Contractors and subcontractors are to make good faith assessments of employees’ labor hours on Section 3 covered contracts/projects for the following:

- Total labor hours worked by all employees (excludes the total labor hours from professional services)
- Total labor hours worked by Section 3 Workers
- Total labor hours worked by Targeted Section 3 Workers

Contractors and subcontractors are to report their good faith assessments of labor hours on the Section 3 Quarterly Labor Hours Report. Exception: Contractors and subcontractors whose contracts are subject to prevailing wage laws are to submit their weekly certified payroll reports, instead of the Section 3 Quarterly Labor Hours Report.

Compliance Monitoring

Section 3 compliance monitoring will be performed by HWS Section 3/EOC Unit. **Contractors and subcontractors who submitted approved Utilization Plans shall maintain their approved percentages of Section 3 participation throughout the term of the contract/project. Contractors and/or subcontractors whose Utilization Plans projected no new hires must, to the greatest extent feasible, hire certified Section 3 Workers or Targeted Section 3 Workers, when the need to hire occurs.**

FREQUENCY OF MONITORING				
Contract Description	Contract Award/ Negotiation	Monthly	Quarterly	Completion
Construction and Maintenance (subject to prevailing wage)	X	X		X
Non-Construction (<3 months’ performance)	X			X
Non-Construction (>3 months’ performance)	X		X	X

Noncompliance with HUD’s regulations in 24CFR75 may result in sanctions, termination of contract for default, and debarment or suspension from future HUD-assisted contracts.

Section 3 Project Implementation Plan

General Submittal Instructions:

Bidder/Proposer AND its first-tier subcontractors are to submit a completed Section 3 Implementation Plan(s) in bid. **If not, A “non-responsive” determination may be made due to non-submittal.**

Project Information:

Project Name:	Bid/Solicitation #:
---------------	---------------------

Contractor **Subcontractor Information**

Company Name:	Address:
Authorized Representative:	Title:
Phone:	Email:
Proposed Dollar Value of Contract or Subcontract:	
List if ELBE, DBE, DVBE, MBE, SB, SLBE or WBE (or “N/A” if non-applicable):	

Section 3 Requirements

Employment and Training

To the greatest extent feasible, employment and training opportunities arising in connection with Section 3 projects shall be provided to Section 3 workers within the County of Riverside. Where feasible, priority for employment and training will be given to:

1. Section 3 workers residing within the service area or neighborhood of the project, and
2. Participants in YouthBuild programs.

Contracting

To the greatest extent feasible, work contracts awarded in connection with Section 3 projects shall be provided to business concerns that provide economic opportunities to Section 3 workers residing within the County of Riverside. Where feasible, priority for contracting opportunities will be given to:

1. Section 3 business concerns that provide economic opportunities to Section 3 workers residing within the service area or the neighborhood of the project, and
2. YouthBuild programs.

Compliance Benchmarks

To demonstrate compliance with Section 3, contractors are required to follow the prioritization of effort outlined above and meet or exceed the following safe harbor benchmarks:

1. 25 percent or more of the total number of labor hours worked by all workers on the project shall be performed by Section 3 workers, and
2. 5 percent or more of the total number of labor hours worked by all workers on the project shall be performed by Targeted Section 3 workers.

Definitions

- **Section 3 worker:** Any worker who currently fits or when hired within the past three years fits at least one of the following categories, as documented:
 - (1) The worker’s income for the previous or annualized calendar year is below the income

Section 3 Project Implementation Plan

limit established by HUD (see Income Limits table below).

- (2) The worker is employed by a Section 3 business concern.
- (3) The worker is a YouthBuild participant.

- **Targeted Section 3 worker:** A Section 3 worker who is:
 - (1) A worker employed by a Section 3 business concern; or
 - (2) A worker who currently fits or when hired within the past three years fit at least one of the following categories, as documented:
 - (i) Living within the service area or the neighborhood of the project; or
 - (ii) A YouthBuild participant.
- **Service area or the neighborhood of the project:** An area within one mile of the Section 3 project or, if fewer than 5,000 people live within one mile of a Section 3 project, within a circle centered on the Section 3 project that is sufficient to encompass a population of 5,000 people according to the most recent U.S. Census.

HUD Income Limits

The table below shows the income limits set by HUD that determine eligibility for certain programs, including Section 3. HUD develops income limits based on Area Median Income (AMI) estimates and Fair Market Rent (FMR) area definitions. For more information, please see the HUD Income Limits Documentation System online at www.huduser.gov/portal/datasets/il.html.

Riverside County, CA MSA			
Fiscal Year	2023	2022	2021
Low-income (80% AMI)	\$52,000	\$49,300	44,250

1. Does your business qualify as a Section 3 business concern? YES NO

If you answered YES, complete the attached Section 3 Business Concern Form (Pg. 6), and submit with this Plan.

A **Section 3 business concern** is a business that satisfies **at least one** of the following criteria, as documented within the last six-month period:

- a. The business is at least 51% owned and controlled by low- or very low-income persons;
- b. The business is at least 51% owned and controlled by residents who currently live in public housing or Section 8-assisted housing; or
- c. Over 75% of the labor hours performed for the business over the prior three-month period were performed by Section 3 workers – i.e., workers who currently are, or when hired within the past three years were:
 - (i) low-income persons or
 - (ii) YouthBuild participants.

2. Do you have current employees whose annual income is below the income limit? See HUD Income Limits table. YES NO

If “YES,” prior to contract execution, the names of qualifying employees shall be provided to HWS.

3. Do you plan to hire new employees to perform on or support the contract, if awarded the contract? YES NO

Section 3 Project Implementation Plan

If “YES,” at a minimum, you must contact the HWS Section 3 Unit at RivCoCDBG@rivco.org to obtain examples of qualitative efforts to create employment.

- 4. Do you agree that when there is a need to hire new employees, a documented good faith effort shall be made to hire Section 3 Workers?** YES NO

Implementation Plans that indicate a “No” response for question #4 may be deemed “non-responsive.”

- 5. How many workers are needed to complete the project?**

Please list the job classifications and number of workers your company will need to complete the contract work. Attach additional sheets if necessary.

Job classification (Office/Clerical, Manager, Engineer, Technician, Supervisor/Foreman, Electrician, Plumber, Laborer, Trainee, Security, etc.)	Total estimated number of workers needed	Number of workers in current workforce	Estimated number of additional workers needed

Section 3 Project Implementation Plan

8. Will you be using subcontractors on this project? YES NO

If “Yes”, Bidder/Proposer is required, to the greatest extent feasible, to outreach to and award subcontracts to Section 3 Business Concerns. **AT A MINIMUM, YOU MUST, CONTACT THE HWS SECTION 3/EOC UNIT AT RivCoCDBG@rivco.org OR GO TO <https://rivcoeda.org/Departments /Housing/Community-Development-BlockGrant/CommunityDevelopment /Section-3-Program> TO OBTAIN “Examples of Efforts to Create Employment and Contracting Opportunities.”**

Section 3 Business Concerns **must complete** the Section 3 Business Concern Form and **must be** certified by HWS. For ELBE, SLBE, SB, DBE, MBE, WBE or DVBE firms, please attach a copy of their certification(s). **List ALL** proposed subcontractors (including subconsultants) for this project on the table below.

Business name	Scope of work (trade or service description)	Section 3 business? Yes / No	Estimated contract value
			\$
			\$
			\$
			\$
			\$
			\$
			\$
			\$
			\$
			\$
			\$
			\$
			\$
			\$
			\$
			\$
			\$
			\$

4. Do you commit to engage in good faith efforts to meet or exceed the Section 3 Benchmarks? YES NO

Such qualitative efforts may include, but are not limited to:

- Applicant Outreach –
 - Engage in outreach efforts to generate job applicants who are Targeted Section 3 workers, including posting job openings at the job site, HUD Opportunity Portal, social media pages, and other platforms.

Section 3 Project Implementation Plan

- Clearly indicate Section 3 eligibility on all job postings, notifications, and advertisements with the following statement: “This is a Section 3 eligible job opportunity. We encourage applications from individuals that are low-income, live in public housing, and/or receive a Section 8 voucher.”
- Include the Section 3 Worker Self-Certification form in all job postings.
- One-Stop / YouthBuild Outreach – Engage in outreach or referrals with local YouthBuild programs, or other community organizations to assist with training and recruiting Section 3 and Targeted Section 3 workers.
- Training and Apprenticeship – Provide training or apprenticeship opportunities.
- Job Fairs – Hold one or more job fairs or sponsor a job informational meeting in the project area.
- Business Concern Outreach –
 - Engage in outreach efforts to identify and secure bids from Section 3 businesses by advertising notices of contracting opportunities and related information in local community papers.
 - Provide written notice to all known Section 3 business concerns, with sufficient time for interested businesses to respond to bid invitations.
 - Send notice of contracting opportunities to local community development organizations, business development organizations, or minority contracting associations.
 - State clearly in all notices that the contracting opportunity is Section 3 eligible and include a copy of the Section 3 Business Concern Certification form.
- Competition Assistance – Provide technical assistance to help Section 3 business concerns understand and bid on contracts.
- Contract Sizing – Size, split, or divide contracts into smaller jobs to facilitate participation by Section 3 business concerns, particularly where economies of scale or efficiency of delivery are not factors. [2 CFR 200.321(b)(3)]
- Bidder Viability Support – Provide bonding assistance, guaranties, or other efforts to support viable bids from Section 3 business concerns.
- Business Registries – Promote the use of business registries designed to create opportunities for disadvantaged and small businesses.

Additional activities and efforts aimed at increasing economic opportunities for Section 3 workers and businesses may include, but are not limited to:

- Employment Assistance – Provide technical assistance to help Section 3 workers compete for jobs, or connect them with assistance in seeking employment, including resume assistance, interview preparation, coaching, or job placement services.
- Work Readiness and Retention – Provide or refer Section 3 workers to services supporting work readiness and retention, such as interview clothing, licensing or testing fees, transportation, or childcare.
- Financial Literacy – Help Section 3 workers obtain financial literacy training or coaching.
- Education Assistance – Assist Section 3 workers to apply for or attend community college, four-year educational institution, or vocational/technical training.

5. Do you commit to prioritize your efforts in hiring, training, and contracting as required by the Section 3 regulations and outlined on page 1 of this Plan? YES NO



SECTION 3 BUSINESS CONCERN FORM

Please complete this form to determine if your business may qualify as a Section 3 Business. Businesses that qualify will be contacted by HWS Section 3 Coordinator to complete a Section 3 Business Application and asked to provide additional documentation to verify their status as a Section 3 Business.

What is Section 3?

Section 3 is a provision of the Housing and Urban Development Act of 1968 (24 CFR Part 75) that requires recipients of certain HUD financial assistance, to the greatest extent possible, to provide job training, employment, and contract opportunities for low- or very low-income residents in connection with projects and activities in their neighborhood.

A business can qualify as Section 3 if it meets one of the following criteria:

- A. It is at least 51% owned and controlled by low- or very low-income persons;
- B. Over 75% of the labor hours performed for the business over the past three-month period were performed by workers who met at least one of the criteria below; or
- C. It is at least 51% owned and controlled by current public housing residents or residents who currently live in Section 8-assisted housing.

Workers must meet one of the following criteria for a business to qualify as Section 3 under item B above:

- Reside within one mile of the Section 3 project (or, if fewer than 5,000 people live within one mile of the Section 3 project, within a circle centered on the Section 3 project that is sufficient to encompass a population of 5,000 people according to the most recent U.S. Census);
- Be a HUD YouthBuild participant; or
- Income for the previous or annualized calendar year is below 80% of the current area median income for the area in which the worker resides. (Use the worker’s annual gross income based on AMI for a single-person household.) HUD income limits can be found at <https://www.huduser.gov/portal/datasets/il.html>.)

Company Name:		
Contact Person:		
Address:		
City:	State:	Zip:
Phone:	Email:	

I have reviewed the above information and my business **MAY QUALIFY** as a Section 3 Business. Please contact me about completing an application and certification.

Signature of Business Owner

Date



Certification for Section 3 Compliance
(Required for Bidder and all Subcontractors)

Project Information:

Project Name:	Bid/Solicitation #:
---------------	---------------------

Contractor/Subcontractor Information:

Company Name:	Address:
Authorized Representative:	Title:
Phone:	Email:

- I. By completing and signing this form, I agree to comply with all applicable requirements of Section 3 of the Housing and Urban Development Act of 1968 (24 CFR Part 75) and HWS' Section 3 requirements.

INITIAL HERE _____
- II. I understand that "to the greatest extent feasible," work contracts awarded in connection with Section 3 projects shall be provided to business concerns that provide economic opportunities to Section 3 workers following the prioritization efforts outlined in Section 3 regulation.

INITIAL HERE _____
- III. I understand that in the event any new employment opportunities are created as a result of this CDBG-funded project then "to the greatest extent feasible" employment and training opportunities shall be provided to Section 3 workers following the prioritization efforts outlined in Section 3 regulation.

INITIAL HERE _____
- IV. I understand the safe harbor benchmarks for Section 3 compliance and that if these benchmarks are not met the contractor will be required to report on the qualitative efforts made to meet the benchmarks.

INITIAL HERE _____
- V. I understand that I will be required to make good faith assessments of employee labor hours on Section 3 covered projects and submit quarterly and final Section 3 reports and supporting documentation.

INITIAL HERE _____
- VI. I understand that any and all sub-contracts and sub-tier agreements resulting from this CDBG-funded project are also subject to Section 3 compliance and that it will be the General/Prime Contractor's responsibility to ensure compliance from all subcontractors.

INITIAL HERE _____
- VII. I understand that noncompliance with HUD's regulations in 24 CFR Part 75 may result in sanctions, termination of contract for default, and debarment or suspension from future HUD-assisted contracts.

INITIAL HERE _____

I declare that all statements contained in this form and any accompanying documents are true and correct and made with full knowledge that all statements given are subject to investigation and that any false or dishonest answer to any question may be grounds for denial or revocation of funding or other penalties as prescribed under 18 U.S. Code § 1001.

Name of President or Authorized Officer

Company Name

Signature and Title

Date



**BIDDER CERTIFICATION ON
FEDERAL CONTRACT REQUIREMENTS**

Project Name: _____ Bid/Solicitation #: _____

CERTIFICATION:

I hereby certify that I have reviewed and understand the diversified Federal construction contract-related requirements imposed on the Contractor(s) of HUD-funded construction projects, including but not limited to the following:

1. The subject project is being financed with Community Development Block Grant funds (*24 CFR Part 570*); and
2. This project and all related construction contracts are subject to the U.S. Department of Housing and Urban Development's Federal Labor Standards Provisions (HUD 4010 – revised 10/2023); and
3. This project is subject to all applicable laws and regulations as listed in the General Summary of these Special Federal Provisions; and
4. If my bid is \$200,000 or more, this project and all related contracts will be subject to Section 3 requirements (12 U.S.C.1701u); and
5. If the project is \$250,000 or more, this project and all related contracts will be subject to comply with the requirements of the Build America, Buy America (BABA) Act (41 USC 8301).

CONTRACTOR'S NAME: _____

CONTRACTOR'S LICENSE NO.: _____

ADDRESS: _____

AUTHORIZED REPRESENTATIVE: _____ (Print Name)

SIGNATURE: _____

DATE: _____

QUESTIONNAIRE REGARDING BIDDERS

Bidder has been engaged in the contracting business under the present name of

_____, since _____ (Date).

Present business address is: _____

Federal Tax ID: _____ **Amount of Bid \$** _____

California Contractor's License No.: _____ **Expiration Date:** _____

UEI Number: _____ **or CAGE Code:** _____

Because this project is Federally funded, it is necessary to obtain information concerning minority and other group participation for statistical purposes. The U.S. Department of Housing and Urban Development (HUD) uses this information to determine the degree to which its programs are being utilized by minority business enterprises and targeted group contractors.

A minority enterprise is defined by the Federal Government as a business that is fifty-one percent (51%) or more "minority-owned". Please check the applicable box concerning the ownership of your business:

- American Indian or Native Alaskan
- Asian or Pacific Islander/Native Hawaiian
- Black/African American
- Hispanic
- White
- Hasidic Jews
- Other _____

A woman-owned enterprise is defined by the Federal Government as a business that is fifty-one percent (51%) or more woman-owned. Please check applicable box concerning the ownership of your business:

- Woman/Female owned Male owned

A Section 3 Contractor or Subcontractor is a business concern that is more than fifty-one percent (51%) owned by a low or very low-income person, or over 75 percent of the labor hours performed for the business over the prior three-month period are performed by Section 3 workers. Please check the applicable box concerning the ownership of your business:

- Section 3 Business concern Non-Section 3 Business concern

The United States Department of Housing and Urban Development (HUD) is authorized to solicit the information requested in this form by virtue of *Title 12, United States Code, Section 1701 et seq.*, and other regulations. It will not be disclosed or released outside of HUD without your consent, except as required or permitted by law.

LIST OF SUBCONTRACTORS

SUBCONTRACTOR	FED. I.D.#	AMOUNT	ADDRESS/PHONE NO.
_____	_____	_____	_____
_____	_____	_____	_____
_____	_____	_____	_____
_____	_____	_____	_____
_____	_____	_____	_____

SUPPLIERS

NAME OF SUPPLIER	ADDRESS/PHONE NO.	CONTRACT AMOUNT
_____	_____	_____
_____	_____	_____
_____	_____	_____
_____	_____	_____

If the project is \$250,000 or more, this project and all related contracts will be subject to comply with the requirements of the Build America, Buy America (BABA) Act (41 USC 8301).

This form is to be completed and submitted with the bid package.

POST CONTRACT AWARD FORMS

PERFORMANCE BOND

Recitals: 1. _____
(Contractor)

has entered into an Agreement dated _____ with _____
_____ for construction of public work known as

(Project)

2. _____, a

_____ corporation (Surety), is the Surety under this Bond Agreement:

We, Contractor, as Principal, and Surety, jointly and severally agree, state, and are bound unto Owner, as obligee, as follows:

1. The amount of the obligation of this Bond is 100% of the estimated contract price for the project of \$ _____ and insures to the benefit of Owner.

2. This Bond is exonerated by Contractor doing all things to be kept and performed by it in strict conformance with the Contract Documents for the Project, otherwise it remains in full force and effect for the recovery of loss, damage and expense of Owner resulting from failure of Contractor to so act. All of said Contract documents are incorporated herein.

3. This obligation is binding on our successors and assigns.

4. For value received. Surety stipulates and agrees that no change, time extension, prepayment to Contractor, alteration or addition to the terms and requirements of the Contract Document or the work to be performed thereunder shall affect its obligations hereunder and waives notice as to such matters, except the total contract price cannot be increased by more than 10% without approval of Surety.

THIS BOND is executed as of _____
Date

By _____ By _____

By _____ Type Name _____
Its Attorney in Fact "Surety"

Title _____
Contractor

Note: This Bond must be executed by both parties with corporate seal affected. All signatures must be acknowledged. (Attach acknowledgments)

PAYMENT BOND
(Public Work - Civil Code 3247 et seq.)

The makers of this Bond are _____ as

Principal and Original Contractor and _____, a

corporation, authorized to issue Surety Bonds in California, as Surety, and this Bond is issued in

conjunction with that certain public works contract dated _____

between Principal and _____ a

public entity, as Owner; for the BOND is one hundred percent (100%) of said sum. Said contract is

for public work generally consisting of _____

The beneficiaries of this Bond are as stated in 3248 of Civil Code and the requirements and conditions of this Bond are as is set forth in 3248, 3249, 3250 and 3252 of said Code. Without notice, Surety consents to extension of time for performance, change in requirements, amount of compensation, prepayment under said contract

Dated _____
Original Contractor - Principal

Surety By _____

By _____ Title _____
(If corporation - affix seal)

(Corporate Seal)

STATE OF CALIFORNIA

COUNTY OF _____) SS SURETY'S ACKNOWLEDGMENT

On _____ before me personally appeared _____

known to me to be the person whose name is subscribed to the within the instrument as attorney in

fact of _____, a corporation, and acknowledged that he subscribed the name of said corporation thereto, and his own name is its attorney in fact.

Notary Public (Seal)

Riverside County Counsel

Approved Form 1-9-74

SUBCONTRACTOR QUESTIONNAIRE

Subcontractor has been engaged in the contracting business under the present name of: _____, since _____ (Date).

Present business address is: _____

Federal Tax ID: _____ **Amount of Subcontract \$** _____

State of California Contractor's License No.: _____

Expiration Date: _____

Because this project is Federally funded, it is necessary to obtain information concerning minority and other group participation for statistical purposes. The U.S. Department of Housing and Urban Development (HUD) uses this information to determine the degree to which its programs are being utilized by minority business enterprises and targeted group contractors.

A minority enterprise is defined by the Federal Government as a business that is fifty-one percent (51%) or more "minority-owned". Please check the applicable box concerning the ownership of your business:

- American Indian or Native Alaskan
- Asian or Pacific Islander/Native Hawaiian
- Black/African American
- Hispanic
- White
- Hasidic Jews
- Other _____

A woman-owned enterprise is defined by the Federal Government as a business that is fifty-one percent (51%) or more woman-owned. Please check the applicable box concerning the ownership of your business:

- Woman/Female owned Male owned

A Section 3 Contractor or Subcontractor is a business concern that is more than fifty-one percent (51%) owned by a low or very low-income person, or a business concern that over 75 percent of the labor hours performed for the business over the prior three-month period are performed by Section 3 workers. Please check the applicable box concerning the ownership of your business:

- Section 3 Business concern Non-Section 3 Business concern

The United States Department of Housing and Urban Development (HUD) is authorized to solicit the information requested in this form by virtue of *Title 12, United States Code, Section 1701 et seq.*, and other regulations. It will not be disclosed or released outside of HUD without your consent, except as required or permitted by law.

DEPARTMENT OF HOUSING & WORKFORCE SOLUTIONS

**CDBG / ESG / HOME PROGRAMS
Contractor / Sub-Contractor Questionnaire**

Note: The information requested is used to compile data required by HUD for Federally funded projects. The information is used by HUD to monitor and evaluate Minority Business Enterprise activities against the total program activity and the designated minority business enterprise (MBE) goals.

Privacy Act Notice = The United States Department of Housing and Urban Development, Federal Housing Administration, is authorized to solicit the information requested in this form by virtue of Title 12, United States Code, Section 1701 et seq., and regulation. It will not be disclosed or released outside the United States Department of Housing and Urban Development without your consent, except as required or permitted by law.

Amount of Contract or Subcontract	Contractor or Subcontractor Business Racial / Ethnic (see below)	Type of Business 1-9	Woman Owned Business (Y or N)	Prime Contractor Identification (ID) Number	Subcontractor Identification (ID) Number	Sec. 3 (Y or N)	Contact Person	Contractor / Subcontractor Name and Address				
								Name State	Street	City		

Racial / Ethnic Codes:

- 1 = White Americans
- 2 = Black Americans
- 3 = Native Americans
- 4 = Hispanic Americans
- 5 = Asian / Pacific Americans
- 6 = Hasidic Jews

Type of Business / Trade Codes

- 1 = New Construction
- 2 = Substantial Rehab
- 3 = Repair
- 4 = Repair
- 5 = Project Management
- 6 = Professional
- 7 = Tenant Services
- 8 = Education Training
- 9 = Arch / Eng Appraisal
- 0 = Other

Section 3: Yes / No

A Section 3 Contractor or subcontractor is a business concern that provides economic opportunities to low and very low-income residents of the metropolitan area (or non-metropolitan county), including a business concern that is 51 percent or more owned by low-income residents.

PRINT NAME: _____

SIGNATURE: _____

DATE: _____

**CERTIFICATION OF SUBCONTRACTOR
REGARDING NONSEGREGATED FACILITIES**

Project Name: _____

Name of Subcontractor: _____

Name of General Contractor: _____

The above-named Subcontractor hereby certifies that:

I do not maintain or provide for my employees any segregated facilities at any of my establishments, and that I do not permit my employees to perform their services at any location, under my control, where segregated facilities are maintained. As used in this certification, the term "segregated facilities" means any waiting rooms, work areas, rest rooms, wash rooms, restaurants, and other eating areas, time clocks, locker rooms or other dressing areas, parking lots, drinking fountains, recreation or entertainment areas, transportation, and housing facilities provided for employees which are segregated by explicit directive or are in fact segregated on the basis of race, color, religion, national origin, or because of habits, local customs, or otherwise.

Signature: _____

Name (Print): _____

Title: _____

Date: _____

**SECTION 3
LIST OF PERMANENT EMPLOYEES**

This form is required for all Section 3-triggered projects (over \$200,000) and must be submitted prior to contract execution and again with the final Section 3 compliance report.

Project Name	Today's Date

Please list all current permanent employees (both full and part-time) employed by your company (or local/regional office), as well as employees of all subcontractors working on this project. Use additional sheets as necessary. A computer-generated employee registry can be provided in lieu of this form if it includes the worker's name, employer and job category and indicates Section 3/targeted Section 3 status.

No.	Name of Worker (Identifying by worker name or worker identification number is appropriate.)	Employer (Indicate if the worker is employed by general/prime contractor or identify applicable subcontractor.)	Job Category/Trade	Section 3 Worker (Y/N)	Targeted Section 3 Worker (Y/N)
1					
2					
3					
4					
5					
6					
7					
8					
9					
10					
11					
12					
13					
14					
15					
16					
17					
18					
19					
20					
21					
22					
23					
24					
25					

Section 3 Worker Employer Certification

Contractors on Section 3 projects must submit this form for each employee reported as a Section 3 worker or Targeted Section 3 worker, as defined in 24 CFR 75.5.

Section 3 Worker Name:	Address:
Position/Job Title:	Project:
Employer Name:	Authorized Representative Name and Title:
Employer Phone #:	Employer Email:

Section 3 Eligibility:

1. Does this employee qualify as a Section 3 worker per 24 CFR 75.5? YES NO

Section 3 worker means any worker who currently fits, or when hired within the past three years fit, at least one of the following criteria, as documented (check all that apply):

- The worker’s income for the previous or annualized calendar year is below the limit established by HUD (see below, or refer to www.huduser.gov/portal/datasets/il.html).
- The worker is employed by a Section 3 business concern.
- The worker is a YouthBuild participant.

HUD Income Limits

Riverside County, CA MSA			
Fiscal Year	2023	2022	2021
Low-income (80% AMI)	\$52,000	\$49,300	44,250

2. Does this employee qualify as a Targeted Section 3 worker per 24 CFR 75.21? YES NO

A Targeted Section 3 worker for housing and community development financial assistance means a Section 3 worker who is (check all that apply):

- A worker employed by a Section 3 business concern; or
- A worker who currently fits or when hired fit at least one of the following categories, as documented within the past three years:
 - Living within the service area or neighborhood of the project, as defined in 24 CFR Part 75.5; or
 - A YouthBuild participant. (If checked, attach a copy of the employee’s self-certification.)

HWS reserves the right to request additional documentation at any time to verify the information provided on this form.

Certification:

By submitting this form, I hereby certify under penalty of perjury that the information provided above is true and correct, and that I am authorized on behalf of the company to make this certification. I agree to provide documentation verifying the employee’s Section 3 eligibility to HWS if requested.

Authorized Representative: _____ **Title:** _____

Signature: _____ **Date:** _____

DOCUMENTATION OF QUALITATIVE EFFORTS

This form is required for all Section 3-triggered projects (over \$200,000) and must be submitted prior to contract execution. Please fill out this form completely. Attach additional pages if needed.

Project Name	Today's Date

- Describe all efforts made to direct the employment and other economic opportunities generated by HUD financial assistance for housing and community development programs, to the greatest extent feasible, to Section 3 workers. Attach additional pages if needed.

Attach supporting documentation such as:

- Copies of all publications, notices, pictures of posted notices, and other outreach materials.
- List of all Section 3 workers that responded to your responded to your outreach efforts (e.g., submitted job applications, phone logs, etc.); were any of them hired? If not, please explain why.

- Describe all efforts made to notify Section 3 businesses of any subcontracting opportunities generated by HUD financial assistance for this project, to the greatest extent feasible. Attach additional pages if needed.

Attach supporting documentation such as:

- List of Section 3 business included in solicitation and documentation of efforts (emails, letters, phone, logs, etc.).
- List of Section 3 businesses that responded to your solicitation and/or outreach efforts; were any of them hired? If not, please explain why.
- Copies of all publications, notices, pictures of posted notices, and any other outreach material utilized.

DOCUMENTATION OF QUALITATIVE EFFORTS

3. Describe all additional qualitative efforts made to comply with Section 3 requirements. See below for examples. Attach all applicable supporting documentation.

4. If there are employment opportunities associated with your project, include a draft of the proposed signage. Section 3 signage should be posted at the construction site. Signage must be large enough to be visible from the street. The sign must (a) identify the name of the project, (b) state the project is a HUD Section 3 Project, and (c) include the name, phone number and email address of an appropriate point of contact regarding employment opportunities.

CDBG PROJECT LABOR CLASSIFICATION AND WAGE RATE

PROJECT NAME:			PROJECT NUMBER:			
COMPANY NAME:			WAGE DECISION NUMBER/MODIFICATION NUMBER:			
WORK CLASSIFICATION	BASIC HOURLY RATE (BHR)	FRINGE BENEFITS	TOTAL HOURLY RATE	LABORER FRINGE BENEFITS:		\$
BRICKLAYER			\$	GROUP #	BHR	TOTAL WAGE
CARPENTERS			\$			\$
CEMENT MASONS			\$			\$
DRYWALL HANGERS			\$			\$
ELECTRICIANS			\$			\$
IRONWORKERS			\$			\$
PAINTERS			\$	OPERATORS FRINGE BENEFITS:		\$
PLUMBERS			\$	GROUP #	BHR	TOTAL WAGE
ROOFERS			\$			\$
SHEET METAL WORKERS			\$			\$
SOFT FLOOR LAYERS			\$			\$
TILE LAYERS			\$			\$
LANDSCAPE/ IRRIGATION FITTERS			\$	TRUCK DRIVER FRINGE BENEFITS		\$
OTHER CLASSIFICATIONS				GROUP #	BHR	TOTAL WAGE
						\$
						\$
						\$
ADDITIONAL CLASSIFICATIONS (HUD Form 4230-A) (Must be approved by HUD and DOL)						
WORK CLASSIFICATION	BASIC HOURLY RATE (BHR)	FRINGE BENEFITS	TOTAL HOURLY RATE	DATE OF HUD SUBMISSION TO DOL	DATE OF DOL APPROVAL	



04 SPECIAL CONDITIONS

CITYWIDE SIDEWALK IMPROVEMENTS CIP R-24



SPECIAL CONDITIONS

CONTENTS

SC-01. PROJECT PHASING AND COORDINATION WITH THE PUBLIC.....	1
SC-02. LANDSCAPE OBSTRUCTIONS	1
SC-03. PRECONSTRUCTION PHOTOS AND VIDEO.....	1
SC-04. COORDINATION WITH BEAUMONT CHERRY VALLEY WATER DISTRICT..	1
SC-05. CONTRACTOR STAGING AREA/MATERIAL STORAGE AREA.....	2
SC-06. INSPECTOR’S FIELD OFFICE.	2
SC-07. PROJECT MEETINGS.	2
SC-08. RECESSED PLATES.	2
SC-09. ENCROACHMENT PERMIT.....	2
SC-10. SCE COORDINATION.....	2



SC-01. PROJECT PHASING AND COORDINATION WITH THE PUBLIC. This project will have an impact on the residents and property owners where the work will be performed. The City will be doing community outreach and having direct communications with the property owners for this project. The Contractor will also be responsible for public notification as described in the Technical Provisions. Under no circumstances shall work begin in front of a property until the contractor has performed their public notification responsibilities, and also confirmed with the City that the property owners have been contacted and are aware of the work that will be performed. The contractor shall continuously notify the City at least three weeks in advance of each area they plan to work. The contractor shall phase the project in such a way that the City and the contractor shall have sufficient time to notify the public.

If the City receives complaints from individuals or agencies affected by the project; the Contractor shall take immediate action to correct the situation as directed by the City. If the Contractor receives complaints directly, the Contractor shall immediately notify the City Inspector. Thereafter, the Contractor shall take immediate action to correct the situation as directed by the City.

SC-02. LANDSCAPE OBSTRUCTIONS. Many sections of sidewalk will require removal of existing landscaping, including but not limited to decorative rock, bricks, block walls, bushes, shrubs, grass, irrigation, concrete steps, pavers, wooden fences, chain-link fences, and other similar obstructions. Work descriptions by address are provided in the Appendices for each address on this project. These have brief descriptions of potential landscape obstructions, potential cuts and fills, and other items not detailed in the Drawings. These are only provided for reference, and the Contractor shall walk the project thoroughly to verify and account for anything not detailed in the work descriptions. The Contractor's bid price shall account for this work as described in the Technical Provisions, and no additional compensation shall be provided.

SC-03. PRECONSTRUCTION PHOTOS AND VIDEO. The Contractor shall take preconstruction photos of the entire project site and shall prepare a full color preconstruction video recording of the project site with the Inspector present prior to mobilizing. Photos and video shall be submitted to the City for review and acceptance.

SC-04. COORDINATION WITH BEAUMONT CHERRY VALLEY WATER DISTRICT. The Contractor shall coordinate with the Beaumont Cherry Valley Water District for the relocation of any hydrants, blow-offs, air-vacs, or water services that conflict with the installation of the new sidewalk. Necessary relocations are noted in the Drawings. All costs for coordination with the Water District shall be included in the Contractor's Bid Price.

SPECIAL CONDITIONS



SC-05. CONTRACTOR STAGING AREA/MATERIAL STORAGE AREA. There is no specific contractor staging area or material storage area identified for this project. It is anticipated that no equipment or material can be stored within the right-of-way for this project. It is the Contractor's responsibility to locate a suitable staging area, material storage area and/or contractor yard in order to effectively execute the Contract work. All costs for this task shall be included in the bid proposal and no additional compensation will be allowed.

SC-06. INSPECTOR'S FIELD OFFICE. No Inspector's Field Office is required for this project. The requirements of GC-29 shall be deleted.

SC-07. PROJECT MEETINGS. The Engineer will schedule monthly progress meetings for the project for the duration of the project. The Contractor's project manager and project superintendent or qualified representative shall attend all progress meetings. As warranted, a representative from the Contractor's sub-consultants or suppliers shall attend. The Contractor shall provide a three week look ahead schedule based on the approved and updated master contractor schedule at each progress meeting. The progress meetings will be held at the City Hall offices. At the Engineer's sole option, the progress meetings may be held at other locations.

From time to time as project conditions warrant, the Engineer may call for additional field meetings. The meetings will be held at the job site. The Contractor's field superintendent shall attend all field meetings.

All costs associated with all project and field meetings shall be included in the applicable bid item(s) on the Bidding Sheet, and no additional compensation shall be made therefore.

SC-08. RECESSED PLATES. Any steel plates placed on the job within existing pavement shall be recessed and flush with existing pavement.

SC-09. ENCROACHMENT PERMIT. All proposed work is within the City's existing rights-of-way. The Contractor shall obtain from the City a no-cost encroachment permit for the project. The Contractor shall submit prepare and submit a permit application and all applicable data to the City prior to construction activities. All costs associated with obtaining and maintaining this permit shall be included in the applicable bid item(s) on the Bidding Sheet, and no additional compensation shall be made therefore.

SC-10. SCE COORDINATION. SCE pole relocation is not a part of this project, and no SCE permits have been acquired by the City. Where SCE poles conflict with the proposed sidewalk, the proposed path of travel shall go behind the SCE poles per Riverside County

SPECIAL CONDITIONS



and ADA Standards, as noted in the Drawings. In some locations, there are guy wires and small service poles (bringing service to a home) that conflict with the proposed sidewalk. Where possible, and as noted in the Drawings, the Contractor should coordinate with SCE to relocate these guy wires and service poles in order to meet ADA requirements.



05 TECHNICAL SPECIFICATIONS

CITYWIDE SIDEWALK IMPROVEMENTS CIP R-24



TECHNICAL PROVISIONS

TABLE OF CONTENTS

TP01.	NOTIFICATION OF RESIDENTS AND BUSINESSES	2
TP02.	SOUND REQUIREMENTS.....	2
TP03.	TRAFFIC CONTROL.....	3
TP04.	WATER POLLUTION CONTROL	7
TP05.	MOBILIZATION	10
TP06.	TEMPORARY CONSTRUCTION SIGN.....	11
TP07.	CONSTRUCTION SURVEY AND MONUMENT PRESERVATION	11
TP08.	CONSTRUCTION WATER AND DUST CONTROL	12
TP09.	REMOVE CONCRETE.....	12
TP10.	HOT MIX ASPHALT.....	13
TP11.	INSTALL NEW SIDEWALK	13
TP12.	PCC PAVEMENT (DRIVEWAY APPROACH)	14
TP13.	INSTALL NEW CURB AND GUTTER.....	15
TP14.	REMOVE TREE.....	16
TP15.	MINOR CONCRETE (CURB RAMPS)	16
TP16.	CURB RAMP DETECTABLE WARNING SURFACE.....	19
TP17.	CURB INLET CATCH BASIN.....	20
TP18.	CURB OUTLET DRAIN	20
TP19.	RELOCATE MAILBOX.....	20
TP20.	RELOCATE CANDLESTICK LIGHT POLE.....	21
TP21.	ADJUST WATER SERVICE METER BOX ELEVATION.....	21
TP22.	GUARANTEE	22



TP01. NOTIFICATION OF RESIDENTS AND BUSINESSES

The Contractor shall provide notice of the work, in person and with printed notification (in English and Spanish language), at least ten (10) working days prior to commencing construction activities, to all residents, schools, agencies, firms, institutions, postal service, Transit Authorities, stores, utilities and waste disposal service providers fronting or affected by the work. Additional printed notification (in English and Spanish language) shall be given not less than forty-eight (48) hours prior to performing any work which will restrict property access, close or partially close the street, or which will restrict or disallow street parking. All schools and churches shall receive seven (7) working days notification prior to performing any work which will restrict property access.

The Contractor shall coordinate with the school district for pick-up and drop-off of school children, with the transit authority for the pick-up and drop off of riders, with waste collection/disposal service providers, with the US postal service to ensure delivery of mail, and with churches for weekly or special activities.

The printed notices shall contain a general description of the work to be done and the date that the work is to be done. The notices shall also include a statement that parking will be restricted as called for on the "NO PARKING" signs to be posted along the street. All public notices must be reviewed and approved by the Resident Engineer prior to its distribution.

The Contractor shall also post printed "NO PARKING-TOW AWAY" signs at one-hundred-foot (100') maximum spacing along each side of the affected street for forty-eight (48) hours prior to the commencement of the sidewalk improvement work. The Contractor shall document the day, date and time the "NO PARKING" signs were posted. Posting of signs on trees and utility poles will not be allowed.

The signs shall contain the day, date, hours and vehicle code section reference that parking will be prohibited on that particular street, CVC 22651L and CVC 22654D. Signs that prohibit or restrict parking shall be removed immediately upon completion of work in the restricted or prohibited area.

The printed notices and the "NO PARKING" signs shall be furnished by the Contractor.

Payment: Full compensation for compliance with the preceding requirements shall be considered as being included in the various Contract items in the bid schedule and no additional compensation will be allowed therefor.

TP02. SOUND REQUIREMENTS

Sound control shall conform to General Conditions Article 25 and the provisions in Section 3-12.2, "Noise Control," of the Standard Specifications and these special provisions.

The noise level from the Contractor's operations, between the hours of 9:00 p.m. and 6:00 a.m., shall not exceed 86 dBA at a distance of 50 feet. This requirement shall not relieve the Contractor from responsibility for complying with local ordinances regulating noise level.



The noise level requirement shall apply to the equipment on the job or related to the job, including but not limited to trucks, transit mixers or transient equipment that may or may not be owned by the Contractor. The use of loud sound signals shall be avoided in favor of light warnings except those required by safety laws for the protection of personnel.

Payment: Full compensation for conforming to the requirements of this section shall be considered as included in the prices paid for the various contract items of work involved and no additional compensation will be allowed therefore.

TP03. TRAFFIC CONTROL

Traffic controls, including but not limited to, vehicular and pedestrian traffic controls, maintenance of vehicular and pedestrian access through work areas, detours, and street closures shall be in accordance with these Technical Provisions, Special Provisions; Traffic Control Plans; California MUTCD, Part 6, Temporary Traffic Control, Caltrans adopted 2014; the current "Work Area Traffic Control Handbook"; and Subsection 7-10, of the current "Standard Specifications for Public Works Construction," including all its subsequent amendments. Nothing in the Special Provisions shall be construed as relieving the Contractor from its responsibility to provide for the safety and convenience of traffic and the public during construction.

In the event of conflict, the order of precedence shall be as follows:

1. Special Provisions
2. Traffic Control Plans
3. California Manual on Uniform Traffic Control Devices, Part 6, Temporary Traffic Control, Caltrans adopted 2014.
4. Work Area Traffic Control Handbook. (WATCH)
5. Standard Specifications

Traffic Control shall be in accordance with the following Special Provisions:

1. All streets shall remain open to through traffic at all times. Street closure is not allowed except as approved by the Engineer. The contractor shall obtain written permission from City Engineer at least ten (10) day prior to road closure. The Contractor shall make provisions to allow local traffic access to the closed streets. The local traffic consists of, but is not limited to, residences, church congregations, farmers, post offices, meter readers, trash pickup, school buses, and emergency vehicles. The Contractor shall provide a smooth travel way and either a flagger and/or signing to direct traffic.
2. The Contractor shall be responsible for the preparation of Traffic Control Plans as necessary for the work. The Traffic Control Plans shall be signed and stamped by a California Registered Traffic Engineer and transmitted to the City for approval no later than fourteen (14) calendar days prior to the scheduled commencement of work. Comments and corrections shall be returned to the Contractor within five (5) working



days. The Traffic Control Plans shall conform to the requirements listed in these Technical Provisions; California MUTCD Part 6, Temporary Traffic Control; the Work Area Traffic Control Handbook; and the Standard Specifications.

3. All traffic controls and safety devices, equipment and materials, including but not limited to cones, channelizers, delineators, flashing warning lights, barricades, high level warning devices (telescoping flag trees), flags, signs, markers, portable barriers, temporary railing (Type-K), temporary fencing, flashing arrow signs, changeable message sign, markings, and flagging equipment shall be provided and maintained in “like new” condition.
4. The Contractor shall furnish and properly install, construct, erect, use and continuously inspect and maintain, twenty-four (24) hours per day, seven (7) days per week, which includes holidays, all said devices, equipment and materials and all temporary and permanent pedestrian and driving surfaces as necessary to provide for the safety and convenience of, and to properly warn, guide, control, regulate, channelize and protect the vehicular traffic, pedestrian traffic, project workers, and the public throughout the entire limits of the work activity and beyond said limits as necessary to include areas affecting or affected by the work, from the date of Notice to Proceed to the completion and acceptance of the work.
5. High-level warning devices (telescoping flag trees) are required at all times for work being performed within the roadway unless otherwise specifically approved by the Engineer.
6. All barricades shall be equipped with flashing warning lights, and all traffic cones shall be no less than 711 mm (28“) in height, except that shorter cones, 305 mm (12“) minimum height, may be permitted during striping maintenance operations where the only function of the cone is to protect the wet paint from the traffic.
7. The entire area of orange and white stripes for barricades shall be Type I, engineering grade, or Type II, super engineering grade, retro-reflective sheeting conforming to the requirements of ASTM Designation: D 4956-95.
8. Type III barricades, no less than 1.83 m (6’) in length and equipped with two (2) Type “N” markers each and two (2) portable flashing beacons each, shall be used to close streets, except as otherwise specifically approved by the Engineer for minor maintenance work of no more than one (1) working day’s duration, on weekdays, or on holidays only, and limited to the hours between 8:30 a.m. and 3:30 p.m. Said barricades shall be placed across the full roadway at each point of closure with the distance between barricades, or between barricades and curbs, not exceeding 3’ except that one (1) 11’ wide gap between barricades shall be provided at the center of the street. Barricades to the right of the street’s center, facing the inbound vehicular traffic, shall also be equipped with one (1) R11-2, “Road Closed” sign, one (1) R11-4, “Road Closed to Thru Traffic,” sign, and a Type P warning sign.



9. Channelizers shall be surface mounted type and shall be furnished, placed and maintained at the locations shown on the Plans or as approved by the Engineer, and shall conform to the provisions in Subsection 12-3.07, "Channelizers," of the State of California Standard Specifications and these Special Provisions.
10. When no longer required for the work as determined by the Engineer, channelizers (except channelizers to be left in place), and underlying adhesive used to cement the channelizer bases to the pavement, shall be removed. Removed channelizers and adhesive shall become the property of the Contractor and shall be removed from the site of work.
11. Reflectorized (both sides) temporary self-adhesive markers, 100mm (4in) wide, shall be applied to unstriped pavement surface before opening the travel way to public traffic. Reflectorized temporary yellow markers shall be used for to delineate the centerline to separate opposing traffic. Reflectorized temporary white markers shall be used to delineate lanes of travel and placed in 600mm (24in) intervals transverse to the road to delineate stop bars and limit lines.
12. The reflectorized temporary markers shall be removed the same day the first coat of striping has been placed on the pavement. The removal of the markers shall be done such a way that the pavement is not damaged.
13. Except as otherwise approved by the Engineer, two-way vehicular traffic shall be maintained at all times within two (2) 11' wide lanes on streets having an effective roadway width of 44' or more with restricted parking. Other streets of lesser widths may be reduced to one (1) 12' wide lane with work activity being limited to one side at a time, and the one-way vehicular traffic being maintained at all times by properly trained and experienced flaggers. All lane closures shall have flashing arrow signs to provide additional, high level, advanced warning.
14. No reduction of the traveled way width shall be permitted on any City street before 9:00 a.m. or after 3:30 p.m., on weekends or holidays, or when active work is not being done, unless otherwise approved by the Engineer.
15. Properly trained and experienced flaggers shall be provided to direct traffic when said traffic is to be interrupted, when two-way traffic is to be reduced to one-way traffic, and at other such times as is necessary to safely pass traffic through or around the work area and when so directed by the Engineer.
16. Vehicular access to occupied residential property may be restricted on weekdays, other than holidays, between the hours of 8:30 a.m. and 3:30 p.m. while essential work activity is taking place only upon approval by the Engineer and providing the Contractor gives the property owner or resident at least forty-eight (48) hour advance written and oral notice.



17. Convenient and safe pedestrian access to schools, churches, occupied residential and business property shall be maintained at all times. Access to mailboxes shall be maintained at all times such that the postal delivery service is not interrupted. Trash pick-up services shall not be interrupted. Access to vacant and unused property may be restricted when approved by the Engineer. Both vehicular and pedestrian access shall be maintained at all times to all other property except as otherwise specifically authorized in writing by the Engineer.
18. Vehicular access to business, school and church driveways shall be maintained at all times during construction.
19. Traffic control and safety devices and equipment being used that becomes damaged, destroyed, faded, graffitied, encrusted, soiled, misplaced, worn out, inoperative, lost, or stolen shall be promptly repaired, refurbished, or replaced. Traffic control and safety devices and equipment being used, that are displaced or not in an upright position from any cause, shall be promptly returned or restored to their proper position.
20. An unobstructed view of all signs and warning devices including, but not limited to, stop signs, stop ahead signs, street name signs, and other regulatory, warning and construction signs, markers, and warning devices shall be maintained at all times. All speed limit signs shall be black on white with signs at either end of the project notifying the motoring public that fines are doubled in construction zones. No trucks or other equipment or materials shall be stopped, parked, or otherwise placed so as to obscure said signs, markers and devices from the view of the vehicular and pedestrian traffic to which it applies.
21. When entering or leaving roadways carrying public traffic, the Contractor's equipment, whether empty or loaded, shall yield to said public traffic at all times, except where the traffic is being controlled by police officers, fire officers, properly trained and experienced flaggers, or at traffic signalized intersections.
22. Stockpiling or storage of materials on any public right-of-way or parking area will not be allowed without the specific written permission of the Engineer. Materials spilled along or on said right-of-way or parking area shall be removed completely and promptly. All stockpile and storage areas shall be maintained in a safe, neat, clean, and orderly condition, and shall be restored to equal or better than original condition upon completion of the work.
23. On projects involving work on, closure of, or partial closure of existing streets, and where vehicular access to the abutting property must be restricted, the work shall be so selected, arranged and scheduled that the person(s) requiring access to said abutting property and residents along said streets affected will be able to park within a reasonable distance of not more than 500' from their homes or destination. In addition, no two adjoining streets shall be closed at the same time, except as otherwise approved by the Engineer. Residents must be given written notice of such restrictions a minimum of 48 hours in advance.



24. When work has been completed on a particular street or has been suspended or rescheduled, and said street is to be opened to vehicular traffic, all equipment, “NO PARKING” signs, other obstructions, and unnecessary traffic control devices and equipment shall be promptly removed from that street, except as otherwise approved by the Engineer.
25. Should the Contractor be neglectful, negligent, or refuse, fail, or otherwise be unavailable to promptly, satisfactorily, and fully comply with the provisions specified and referred to herein above, the City reserves the right to correct or mitigate any situation, that in the sole opinion of the Engineer, constitutes a serious deficiency or serious case of noncompliance, by any means at its disposal at the Contractor’s or permittee’s expense, and shall deduct the cost therefore from the Contractor’s progress or final payments. Such corrective action taken by the City shall not reduce or abrogate the Contractor’s legal obligations and liability for proper traffic control and safety measures and shall not serve to transfer said obligations and liabilities from the Contractor to the City or the City’s agents.
26. Streets determined to be major thoroughfares by the Engineer shall undergo construction in stages, or as approved by the field inspector, to allow at least one 10 ft. wide traffic lane for each direction of travel at all times. The Engineer will approve street closures for construction, as necessary, based on the approved construction schedule.
27. Violations of any of the above Provisions or provisions of the referenced publications, unless promptly and completely corrected to the satisfaction of the Engineer, shall, at the sole discretion of the City, be grounds for termination of the Contract, or shut down or partial shutdown of the work, without compensation to the Contractor or permittee, or liability to the City, all as prescribed by contractual obligation or State law, whichever is applicable.

EXCEPTION: Contractor may not work on a street that is in front of a school between the hours of 7:00 AM and 3:30 PM. Monday through Friday unless written authorization is given by the City Engineer. All streets abutting a school ground can only be worked on during weekends.

Payment: Full compensation for conforming to the requirements of this section shall be considered as included in the prices **paid for the various contract items** of work involved and no additional compensation will be allowed therefore.

TP04. WATER POLLUTION CONTROL

Throughout the term of this contract, the total soil disturbance area of the project site shall be less than 1 acre. The Contractor shall comply with the Area-Wide Municipal Stormwater Permit NPDES No. CAS 618033, hereafter referred to in this section as the “Municipal Permit”, issued by the California Regional Water Quality Control Board (CRWQCB) – Santa Ana Region. This Permit regulates both stormwater and non-stormwater discharges associated with Contractor’s construction activities. A copy of the Permit may be obtained on the internet at: <http://www.waterboards.ca.gov/santaana/>



The Contractor shall comply with the requirements of the Municipal Permit, and all other applicable federal, state and local laws, ordinances, statutes, rules, and regulations concerning water pollution control.

The WPCP shall include Fact Sheets for all selected project BMPs.

Contractor's Water Pollution Control Program (WPCP) shall be prepared by a Qualified SWPPP Developer in accordance with Section 3, "Preparing a Water Pollution Control Program (WPCP)", of the Caltrans Stormwater Pollution Prevention Plan (SWPPP) and Water Pollution Control Program (WPCP) Preparation Manual (June 2011), which is available as a free download from:

<http://www.dot.ca.gov/hq/construc/stormwater/manuals.htm>

WATER POLLUTION CONTROL MEASURES

- A. Work having the potential to cause water pollution shall not commence until the Contractor's WPCP has been reviewed and approved by the Engineer. The Engineer's review and approval of the Contractor's WPCP shall not waive any contractual requirements and shall not relieve the Contractor from achieving and maintaining compliance with all federal, state, and local laws, ordinances, statutes, rules, and regulations. A copy of Contractor's WPCP shall be maintained onsite. When the WPCP or access to the construction site is requested by a representative of a federal, state, or local regulatory agency, Contractor shall make the WPCP available and Contractor shall immediately contact the Engineer. Requests from the public for the Contractor's WPCP shall be directed to the Engineer.

- B. Contractor's WPCP shall describe the Contractor's plan for managing runoff during each construction phase. Contractor's WPCP shall describe the Best Management Practices (BMPs) that will be implemented to control erosion, sediment, tracking, construction materials, construction wastes, and non-stormwater flows. BMP details shall be based upon California Stormwater Quality Association's (CASQA) California Stormwater Quality BMP Handbook Subscription Portal (<http://www.cabmphandbooks.com>) or the Caltrans Construction Site BMP Manual
<https://dot.ca.gov/programs/construction/storm-water-and-water-pollution-control/manuals-and-handbooks>
Contractor's WPCP shall describe installation, operation, inspection, maintenance, and monitoring activities that will be implemented for compliance with the Municipal Permit and all applicable federal, state, and local laws, ordinances, statutes, rules, and regulations related to the protection of water quality.

- C. The Contractor's WPCP preparer shall have been trained to prepare WPCPs or SWPPPs and shall have previous experience with preparing SWPPP or WPCP requirements on a previous project.
The Contractor shall designate a Water Pollution Control Manager that shall have been trained to implement WPCP or SWPPP requirements. Contractor's Water Pollution Control Manager shall:
 - 1. Be responsible for all water pollution control work.



2. Be the Engineer's primary contact for all water pollution control work.
3. Have the authority to mobilize resources (crews, supplies, equipment, etc.) to make immediate repairs of water pollution control measures or to supplement water pollution control measures to maintain compliance with all federal, state, and local laws, ordinances, and regulations related to the protection of water quality, including the Municipal Permit.

The WPCP shall contain all required and applicable certifications and evidence of training for the Water Pollution Control Manager, WPCP Developer, and all other employees working on the project receiving formal training or certification.

- D. Water Pollution Control Training: Contractor shall provide water pollution control training to Contractor's employees and subcontractors prior to their performing work on the work site. The water pollution control training shall be appropriate to the employee or subcontractor function and area of responsibility and shall address (as applicable):
1. Erosion Control (water and wind)
 2. Sediment Control
 3. Tracking Control
 4. Materials & Waste Management
 5. Non-Stormwater Discharge Management
 6. Run-on and Run-off Control
- E. Monitoring and Reporting: Observations and inspections conducted by the Contractor's Water Pollution Control Manager shall be documented on the Construction Site Inspection Checklist included in Contractor's WPCP. A copy of each completed Construction Site Inspection Checklist shall be submitted to the Engineer within 24 hours of conducting the inspection

General Requirements:

In the event the City incurs any Administrative Civil Liability (fine) imposed by the CRWQCB – Santa Ana Region, the State Water Resources Control Board, or EPA, as a result of Contractor's failure to fully implement the provisions of "Stormwater and Non-Stormwater Pollution Control", the Engineer, may, in the exercise of his sole judgment and discretion, withhold from payments otherwise due Contractor a sufficient amount to cover the Administrative Civil Liability including City staff time, legal counsel, consultant support costs and all other associated cost.

The Contractor shall be responsible for all costs and for any liability imposed by law as a result of the Contractor's failure to comply with the requirements set forth in "Water Pollution Control", including but not limited to, compliance with the applicable provisions of the Caltrans Handbooks, Municipal Permit, Federal, State, and local regulations. For the purpose of this paragraph, costs and liabilities include, but not limited to, fines, penalties, damages, and costs associated with defending against enforcement actions whether taken against the City or the Contractor, including those levied under the Federal Clean Water Act and the State Porter-Cologne Water Quality Act.

Within fifteen (15) working days after the award of the contract, the Contractor shall submit two (2) copies and one pdf file of the WPCP to the Engineer for review and approval. The Contractor shall allow ten (10) working days for the Engineer to review the WPCP. If revisions are required



as determined by the Engineer, the Contractor shall revise and resubmit the WPCP within three (3) working days of receipt of the Engineer's comments and shall allow ten (10) working days for the Engineer to review the revisions. The Contractor shall submit four (4) copies of the approved WPCP and one pdf. file to the Engineer prior to notice to proceed. The Contractor must have an approved WPCP prior to the notice to proceed.

Unless otherwise directed by the Engineer or specified in these Special Provisions, the Contractor's responsibility for WPCP implementation shall continue throughout any temporary suspension of work.

The Engineer may withhold progress payments or order the suspension of construction operations without an extension of the contract time, if the Contractor fails to comply with the requirements of "Water Pollution Control" as determined by the Engineer.

All BMP repairs shall be implemented by the Contractor within 72 hrs of notification by engineer.

Payment: Full compensation for conforming to the requirements of this section shall be considered as included in the prices **paid for the various contract items** of work involved and no additional compensation will be allowed therefore.

TP05. MOBILIZATION

Mobilization shall conform to General Conditions, Article 45 and the following:
Mobilization shall consist of preparatory work and operations, including, but not limited to those necessary for the movement of personnel, equipment, supplies and incidentals to the project site and for all other work and operations which must be performed or costs incurred prior to beginning work on the various contract items on the project site.

De-mobilization shall consist of the completion of all final construction and administrative work required to secure the project for termination and acceptance by the Engineer, including, but not limited to the following:

1. Satisfactory completion of Finishing Roadway;
2. Removal of all temporary facilities, construction office, temporary utilities, temporary BMPs, plant, equipment, surplus material, construction debris and similar from project limits and adjacent property, as required and as directed by the Engineer;
3. Restoration of all temporary roads and haul routes and construction storage and office areas, etc. to original or better condition;
4. Completion of record of drawings (as-built), to the satisfaction of the Engineer;
5. Submission of final certified payroll documents to the Engineer;
6. Completion of the requirements of permits issued by other agencies;
7. Satisfactory completion of all other contractually and legally required construction and administrative items of work.



Payment: Full compensation for conforming to the requirements of this section shall be considered as included in the prices **paid for the various contract items** of work involved and no additional compensation will be allowed therefore.

TP06. TEMPORARY CONSTRUCTION SIGN

The Contractor shall install a temporary construction sign at the project limits, as approved by the Engineer. The contractor shall relocate the signs as work transitions from area to area or as directed by the City Engineer.

Project signs shall conform to the requirements outlines in the Special Federal Provisions of these specifications in accordance with the CDBG Construction requirements.

- Outside sign dimensions shall be 4' x 8'; material shall be 3/4" marine grade plywood substrate painted in accordance with CDBG requirements.
- Printing shall be black, except city logo, using latex or eco solvent UV inhibited ink
- Contractor shall provide "final proof" layout for Public Works approval.
- Contractor shall provide photo of actual sign to city for approval prior to installation
- Contractor shall install signs at project site at locations approved by engineer
- Sign shall be securely mounted on 2 - 4"x4" wood posts set 5'(min) into stable earth. Sign shall be 18" (min) clear of vehicular and pedestrian travel ways. Bottom of sign shall be 7' (min) above finished grade.
- Contractor shall be responsible to maintain sign in good condition, graffiti free, for the duration of the project and at the completion of the project shall remove the sign and posts, restore area to pre-existing condition, and deliver sign to the Public Works Department.

Payment: Full compensation for project signs shall be made at the contract amount for **each sign**, and shall include full compensation for, but not limited to, furnishing all labor, materials, tools, equipment, relocation, and incidentals, for doing all work involved and no additional compensation will be allowed therefor.

TP07. CONSTRUCTION SURVEY AND MONUMENT PRESERVATION

Construction Survey, Staking and Monument Preservation includes qualified personnel, equipment, and supplies required for, but not limited to Project control, grading, paving, tie out of all centerline monuments, replacement of disturbed monuments, and additional items included in the contract documents.

The Contractor shall employ engineers or surveyors to perform adequate surveys and staking necessary to construct the work to the proper lines and grades. Reconstructed asphalt concrete surfaces shall have a cross slope between 1.5% and 5%. New curb & gutter shall have a minimum slope of 0.5%. Grade breaks must be spaced a minimum 25' apart and be no greater than 0.25%. Copies of the field notes, cut sheets or diagrams used in setting stakes shall be promptly furnished to the Engineer.

The contractor will be responsible to provide pre and post-construction corner records for the City to file with Riverside County.



Payment: Full compensation for conforming to the requirements of this section shall be considered as included in the prices **paid for the various contract items** of work involved and no additional compensation will be allowed therefore.

TP08. CONSTRUCTION WATER AND DUST CONTROL

The Contractor shall obtain construction water from Beaumont Cherry Valley Water District. Temporary construction water meters are available from the District. These meters will require the Developer/Contractor make application at the District offices and pay all the required deposits/fees. Contractor shall comply with South Coast Air Quality Management District Rule 403 – Fugitive Dust. Contractor shall use water trucks or other means to actively prevent, reduce, and mitigate dust emissions using the best available control measures as referenced in Rule 403.

Payment: Full compensation for conforming to the requirements of this section shall be considered as included in the prices **paid for the various contract items** of work involved and no additional compensation will be allowed therefore.

TP09. REMOVE CONCRETE

Remove Concrete shall conform to the requirements of Part 4 “Existing Improvements” of the Standard Specifications, and these Technical Provisions.

This Bid Item shall include all labor, material and equipment required to sawcut, remove, haul away and properly dispose of existing curb and gutter, curb ramps, concrete cross gutter, existing sidewalk, existing driveway and existing driveway approach as identified in the plans and specifications. Broken concrete, asphalt and debris shall be disposed of concurrently with its removal. Stockpiling will not be allowed without prior written approval of the Engineer.

The Contractor shall furnish trash bins for all debris from construction. All debris shall be placed in trash bins daily. Forms and false-work that are to be re-used shall be stacked neatly concurrently with their removal. Forms and false-work that are not to be re-used shall be disposed of concurrently with their removal.

The Contractor shall repair or replace all existing improvements within the right-of-way which are not designated for removal (e.g., curbs, sidewalks, driveways, fences, walls, signs, utility installations, pavement, structures, etc.) which are damaged or removed as a result of the Contractor’s operations.

If the Contractor encounters material in demolition or work that he has reason to believe may be hazardous waste, as defined by Section 25117 of the Health and Safety Code, he shall immediately so notify the Engineer in writing. Demolition in the immediate area of the suspected hazardous material shall be suspended until the Engineer authorizes it to be resumed. If such suspension delays the current controlling operation, the Contractor will be granted an extension of time.



Payment: The contract unit price bid per **each** (for REMOVE EXISTING DRIVEWAY APPROACH) and per **length feet** (for REMOVE EXISTING SIDEWALK and REMOVE EXISTING CURB & GUTTER) shall include full compensation for all labor, tools, equipment, loading, hauling, and disposing of materials.

TP10. HOT MIX ASPHALT

HMA shall conform to Green Book section 203-6, "Asphalt Concrete". HMA shall be installed in accordance with Green Book section 302-5, "Asphalt Concrete Pavement."

Project Mix: C2-PG 64-10-R05

Existing pavement markers shall be removed flush with the existing pavement prior to constructing asphalt concrete pavement.

Where asphalt concrete pavement is designated to be constructed on existing aggregate base, the existing base shall be compacted and graded in accordance with Subsection 301-2.3, "Compacting," of the Standard Specifications.

The asphalt concrete pavement shall be spread with a self-propelled mechanical spreading and finishing machine. The Contractor shall have sufficient workers and equipment necessary to accomplish proper placement and compaction of the asphalt concrete pavement to the satisfaction of the Engineer.

Payment: Full compensation for conforming to the requirements of this section shall be considered as included in the prices **paid for the various contract items** of work involved and no additional compensation will be allowed therefore.

TP11. INSTALL NEW SIDEWALK

The work under this item shall include all labor, material and equipment required to construct new sidewalk for the project. Concrete sidewalk shall be 4-Inch thick and shall conform to the provisions of Section 16 "Concrete Curb and Gutter and Sidewalk" of the County of Riverside Road Standards and Specifications (Ordinance 461), Plans, and these Technical Provisions. Subgrade preparation shall be per Section 19 "Earthwork" and 73 "Concrete Curbs and Sidewalk" of the Caltrans Standard Specifications. Sidewalk shall be constructed per County of Riverside Standard Drawing 401. Where sidewalk needs to go behind existing Edison poles, contractor shall use County of Riverside Standard Drawing 400.

Many sections of sidewalk will require removal of existing landscaping, including but not limited to decorative rock, bricks, block walls, bushes, shrubs, grass, irrigation, concrete steps, pavers, wooden fences, chain-link fences, and other similar obstructions. This bid items shall include removal of all conflicting landscaping as described herein in order to install the new sidewalk. Short descriptions of the properties are provided in the Appendices for reference, however the contractor is required to **walk the project** prior to bidding in order to provide an



accurate bid price to account for landscaping obstructions. No additional compensation shall be provided for the removal of landscape obstructions.

Fences and block walls in conflict with the proposed sidewalk shall be relocated by the contractor in coordination with the individual property owners. All impacted irrigation shall be repaired by the contractor. All other landscape obstructions removed by the contractor shall be the responsibility of the individual property owners to replace.

All existing street signs that conflict with the proposed new sidewalk shall be relocated behind the proposed sidewalk where feasible; or if this is not possible than they shall be located 12-inches behind the curb face. Work to relocate street signs is included in this bid item. Street signs shall not block the sidewalk or be in a location that conflicts with ADA standards.

Many sections of the sidewalk will also require substantial elevation cuts (or fills) in order to install the new sidewalk. Where cuts are required, the contractor shall daylight back to existing grade at a 2:1 slope. Where cuts are greater than two (2) feet, or where there is not sufficient space to daylight back to existing grade, the contractor shall provide a retaining curb per County of Riverside Standards. All labor and materials for cut, fill, grading, daylighting back to existing grade, or providing retaining curb, are included in this bid item. Short descriptions of the properties are provided in the Appendices for reference, however the contractor is required to **walk the project** prior to bidding in order to provide an accurate bid price to account for all cut and fill. No additional compensation shall be provided for cut, fill, grading, and retaining curb required to install the new sidewalk.

Payment: The contract unit price bid per **length foot** for the item “INSTALL NEW SIDEWALK” shall include full compensation for all labor, tools, equipment, loading, hauling, disposing of materials, import of material, compaction and incidentals for doing work involved. Unit cost also includes removal of all landscape obstructions, relocation of any fences and block walls, relocation of existing street signs, irrigation repair, and all cuts, fills, grading, and retaining curbs required to install the new sidewalk.

TP12. PCC PAVEMENT (DRIVEWAY APPROACH)

The work under this item shall include all labor, material and equipment required to construct PCC driveway approaches for the project. Concrete driveway approaches shall conform to the provisions of Section 16 “Concrete Curb and Gutter and Sidewalk” of the County of Riverside Road Standards and Specifications (Ordinance 461), Section 73 “Concrete Curbs and Sidewalk” of the Caltrans Standard Specification, Plans, and these Technical Provisions.

Concrete driveway approaches shall be 8-Inch thick per County of Riverside Standards. Subgrade preparation shall be per Section 19 “Earthwork” and 73 “Concrete Curbs and Sidewalk” of the Caltrans Standard Specifications and subgrade soil shall be compacted to minimum 95% relative compaction.



It may be required to adjust the elevation of existing driveways in private properties to match proposed driveway approach. Removal of any private improvements should be coordinated in writing with the owner and it is Contractor's responsibility to obtain owner's written approval for removal prior to construction.

Measurement: Measurement for PCC Pavement (Driveway) shall be between the public right-of-way limit or back of sidewalk, whichever is larger, to the gutter lip in front of the driveway. Driveways shall include sidewalk, curb and gutter, curb depressions and any retaining curb required as shown on Plans.

Payment: The contract unit price per **each** for the item "PCC PAVEMENT (DRIVEWAY APPROACH) shall include full compensation for all items of the work and all appurtenant work for, but not limited to, furnishing all labor, materials, excavation, subgrade preparation, compaction, tools, equipment, and incidentals, for doing all work involved and no separate or additional compensation will be allowed therefor. Aggregate base placed under driveways shall be included in the unit price paid for under this Bid Item and no additional compensation will be allowed.

TP13. INSTALL NEW CURB AND GUTTER

The work under this item consists of all labor, material and equipment required to construct curb and gutter for Bid Item **INSTALL NEW CURB & GUTTER** complete in place.

Work shall conform to the requirements of Section 16 "Concrete Curb and Gutter and Sidewalk" of the County of Riverside Road Standards and Specifications (Ordinance 461), Plans, and these Technical Provisions. Curb and Gutter shall be constructed per County of Riverside Standard Drawings 200, 201, and 205 as applicable.

Curb and Gutter includes the saw cutting and full AC reconstruction of a 3' wide (slot pavement with 2-sack PCC slurry) portion of AC pavement adjacent to the curb and gutter. A minimum of a 3' saw cut and pavement replacement will be required in all areas of curb return replacements adjacent to existing pavement. The proposed pavement section shall be full depth asphalt paving to match the existing pavement section thickness.

This Bid Item shall include all labor, material and equipment required to construct curb and gutter and longitudinal gutter transitions, complete in place, per these Technical Provisions and as shown on Plans.

Measurement: The quantities of new Curb & Gutter, complete in place, to be paid for shall be measured per Linear Foot (LF), as agreed in the field, and no additional compensation will be allowed.

Curb and gutter shall not be included where feature is included in other items, including but not limited to, curb ramps, driveways, catch basins, grate inlets and local depressions.



Payment: The contract unit price per **length foot** shall include full compensation for all items of the work and all appurtenant work for, but not limited to, furnishing all labor, materials, tools, equipment, excavation, subgrade preparation, compaction, and incidentals, for doing all work involved and no separate or additional compensation will be allowed.

TP14. REMOVE TREE

The work under this item shall be in accordance with the provisions of Section 300-1, “Clearing and Grubbing” and Part 4, “Existing Improvements” of the Standard Specifications, Plans, and these Technical Provisions.

Existing trees to be removed are different species and vary in size. All trees regardless of size shall be removed. To assist in bidding, two separate bid items have been established. “REMOVE TREE (SMALL)” includes any trees that are shorter than approximately 20 feet, and any palm trees. “REMOVE TREE (LARGE)” includes any trees that are taller than 20 feet (approx.). Some large trees stand as high as approximately 80 to 100 feet and are very large in diameter with extensive branch and root structures. The contractor is required to **walk the project** prior to bidding in order to provide an accurate bid price to account for all tree removal costs. No additional compensation shall be provided for the removal of trees.

Removal work includes carefully cutting trees apart while working around and avoiding damage to conflicting power lines and homes. Tree stump and root ball shall be removed by grinding at least 36” deep below final grade. All sideway and shallow root systems shall be removed as a part of tree removal and no further compensation is allowed. The removal areas shall be replaced by approved compacted fill to the satisfaction of the Engineer.

All materials shall be lawfully disposed of at a site secured by the Contractor. The contractor shall make an effort to recycle excavated and removed materials. The contractor shall provide the Engineer with a letter indicating the final disposition of all materials from the project within five (5) working days after project completion.

Payment: The contract unit price per **each** shall include full compensation for doing all work, including furnishing all materials, labor, equipment, tools, hauling, disposal, and incidentals as required and no additional compensation will be allowed.

TP15. MINOR CONCRETE (CURB RAMPS)

Concrete Curb Ramps shall be per SPPWC Standard Plan 111 and County of Riverside Standard Plans, case and type per plans. Concrete shall be Class 520-C-2500.

The geometry shown on the plans is representational. The final limits and geometry of the required curb ramp shall be verified and placed in the field by the contractor in order to ensure the required grades and clearances are obtained.

Curb and Gutter Shall be included in the limits of the Curb Ramp which includes the sawcutting



and full AC reconstruction of a 3' wide (slot pavement with 2-sack PCC slurry) portion of AC pavement adjacent to the curb and gutter in order to achieve the required 5% maximum grade for 4' adjacent to the curb face. **A minimum of a 3' saw cut and pavement replacement will be required in all areas of curb return replacements adjacent to existing pavement.** In locations for a 3' slot pave with 2-sack PCC slurry is inadequate at achieving the required 5% maximum grade and would create adverse driving conditions for the 1' transition, each location shall be individually documented in the construction project files justifying the reason for non-compliance. The proposed pavement section shall be full depth asphalt paving to match the existing pavement section thickness.

Construction of any necessary retaining curbs at the back of ramp or wings of the ramp are included as part of this bid item. The contractor shall install retaining curbs within the ramps to ensure that the constructed ramp is fully ADA compliant while joining existing grades at the back of walk/ramp.

When curb ramp removal and installation is adjacent to PCC cross gutters that are not abandoned/buried then the concrete shall be sawcut 4" off the existing curb face, and the new concrete shall be doweled and epoxied into the existing cross gutter spandrel at 12" on center using 18" #4 bars.

All work within the 1' rumble strip at grade breaks of the sidewalk shall be considered as part of the curb ramp. All work past the 1' rumble strip, which has been approved by the engineer, shall be considered as extra sidewalk or curb and gutter items and will be paid for per the respective unit price.

Existing surfaces to be joined shall be sawcut on a neat, straight line at the join location. All sawcut locations along existing cross gutters shall be cut in a curve conforming to the existing curb return and shall be cut at a set offset from the flow line as approved by the City Engineer. The flow line shall be maintained, ensuring that ponding does not occur in the existing cross gutter.

Any and all Traffic Signals, or pedestrian push button poles, traffic signal poles and other surface mounted appurtenances shall be protected in place and/or re-attached as part of this bid item.

All pull boxes within curb ramp limits shall also be adjusted to the finished grade of the new curb ramp and shall be paid for per the unit price for each respective bid item.

All water or gas valve can and lids within curb ramp limits shall also be adjusted to the finished grade of the new curb ramp and shall be paid for per the unit price for each respective bid item.

The City Engineer shall have final say regarding the case and type of curb ramp to be installed and shall retain the right to revise the ramp designation at any point prior to construction.

The contractor shall verify existing grades in order to ensure full ADA compliance

Curb ramps shall be constructed with detectable warning surfacing complying with California Building Code Title 24. Detectable warning surfacing shall consist of vitrified polymer composite,



with at least 25% by weight aluminum oxide, nominally 0.20" thick, colorfast and UV stable. Panels must be embedded in new ramps. Embedded panels shall have perforated embedment ribs at 3" on center, at least 1" deep.

Other physical characteristics shall be as follows:

Compressive Strength	Greater than 18,000 psi	ASTM D 695
Flexural Strength	Greater than 24,000 psi	ASTM D 790
Tensile Strength	Greater than 10,000 psi	ASTM D 638
131		
Water Absorption	Less than 0.35%	ASTM D 570
Slip Resistance	Greater than 0.80	ASTM C 1028
Flame Spread	Index Less than 25	ASTM E 84
Salt Spray	No Change (200 hours)	ASTM B 117
Chemical Stain Testing	No Deterioration	ASTM 1308
Abrasion Resistance	Less than 0.030 (1,000 cycles)	ASTM D 2386
Accelerated Weathering	No Damage (2,000 hours)	ASTM G 29
Load Bearing at 16,000 lbs.	No Damage	AASHTO-H20
Freeze / Thaw / Heat	No Disintegration	ASTM C 1026

The color of the panels shall be yellow complying with the Federal Standard 595B, color No. 33538. truncated domes. The Contractor shall install panels in accordance with manufacturer's recommendations. The cost of installing detectable warning service panels on new ramps shall be included in the cost of the curb ramp.

This bid item also includes removal of all landscape obstructions, relocation of any fences and block walls, irrigation repair, and all cuts, fills, grading, and retaining curbs required to install the new curb ramps. Short descriptions of the existing conditions are provided in the Appendices for reference, however the contractor is required to **walk the project** prior to bidding in order to provide an accurate bid price to account for landscaping obstructions and cut and fill requirements. No additional compensation shall be provided.

Retrofitting detectable warning surfaces on existing ramp or walkway surfaces shall be paid for as part of their respective bid items.

Payment: The contract unit price bid per **each** for the item "MINOR CONCRETE (RAMPS)" shall include full compensation for all labor, tools, equipment, loading, hauling, disposing of materials, import of material, compaction and incidentals for doing work involved. Unit cost also includes removal of all landscape obstructions, relocation of any fences and block walls, irrigation repair, and all cuts, fills, grading, and retaining curbs required to install the new curb ramps.



TP16. CURB RAMP DETECTABLE WARNING SURFACE

This work includes installing detectable warning surfaces on the curb ramps or as necessary to bring the ramp into compliance.

Curb ramps shall be constructed with detectable warning surfacing complying with California Building Code Title 24. Detectable warning surfacing shall consist of vitrified polymer composite, with at least 25% by weight aluminum oxide, nominally 0.20" thick, colorfast and UV stable. Panels must be embedded in new ramps. Embedded panels shall have perforated embedment ribs at 3" on center, at least 1" deep.

Other physical characteristics shall be as follows:

Compressive Strength	Greater than 18,000 psi	ASTM D 695
Flexural Strength	Greater than 24,000 psi	ASTM D 790
Tensile Strength	Greater than 10,000 psi	ASTM D 638
131		
Water Absorption	Less than 0.35%	ASTM D 570
Slip Resistance	Greater than 0.80	ASTM C 1028
Flame Spread	Index Less than 25	ASTM E 84
Salt Spray	No Change (200 hours)	ASTM B 117
Chemical Stain Testing	No Deterioration	ASTM 1308
Abrasion Resistance	Less than 0.030 (1,000 cycles)	ASTM D 2386
Accelerated Weathering	No Damage (2,000 hours)	ASTM G 29
Load Bearing at 16,000 lbs.	No Damage	AASHTO-H20
Freeze / Thaw / Heat	No Disintegration	ASTM C 1026

The color of the panels shall be yellow complying with the Federal Standard 595B, color No. 33538. truncated domes. The Contractor shall install panels in accordance with manufacturer's recommendations. The cost of installing detectable warning service panels on new ramps shall be included in the cost of the curb ramp.

The manufacturer must provide a written 5-year warranty for detectable warning surface, guaranteeing replacement when there is a defect in the dome shape, color fastness sound-on-cane acoustic quality, resilience, or attachment. The warranty period shall begin upon acceptance of the contract.

Payment: "CURB RAMP DETECTABLE WARNING SURFACE" for new ramps shall be considered as included with the contract unit price paid for the MINOR CONCRETE (RAMPS). For existing ramps the contract unit bid price **per each** for the item "CURB RAMP DETECTABLE WARNING SURFACE" shall include full compensation for all labor, tools, equipment, loading, hauling, disposing of materials, import of material, compaction and incidentals for doing work involved. Adjustment of compensation will be made for any increase or decrease in the quantities at the stipulated unit price.



TP17. CURB INLET CATCH BASIN

The work under this item shall include all labor, material and equipment required to furnish and install a curb inlet catch basin per County or Riverside Standards (Standard Drawing 300), Section 51 “Concrete Structures” and Section 52 “Reinforcement” of the Caltrans Standard Specifications, Plans and Technical Provisions.

This bid item shall include temporary support of all sloped and vertical plains of excavation. Shoring where needed shall be placed to protect existing and proposed improvement including adjacent properties. The contractor shall submit the calculation to the City’s prior commencement of the construction.

Payment: The contract unit price bid per **each** for the item “CURB INLET CATCH BASIN” shall include full compensation for furnishing all labor, materials, tools, equipment, forming, steel reinforcement, trenching, trench support, shoring, excavation, subgrade preparation, compaction, pouring, finishing, hauling, backfilling, restoration, disposing, grate, curb and gutter within limits of gutter depression and incidentals and for doing all the work involved complete in place and no additional compensation will be allowed.

TP18. CURB OUTLET DRAIN

The work under this item shall include all labor, material and equipment required to furnish and install a curb outlet drain per County or Riverside Standards (Standard Drawing 308), Section 51 “Concrete Structures” and Section 52 “Reinforcement” of the Caltrans Standard Specifications, Plans and Technical Provisions.

This bid item shall include temporary support of all sloped and vertical plains of excavation. Shoring where needed shall be placed to protect existing and proposed improvement including adjacent properties. The contractor shall submit the calculation to the City’s prior commencement of the construction.

Payment: The contract unit price bid per **each** for the item “CURB OUTLET DRAIN” shall include full compensation for furnishing all labor, materials, tools, equipment, forming, steel reinforcement, trenching, trench support, shoring, excavation, subgrade preparation, compaction, pouring, finishing, hauling, backfilling, restoration, disposing, grate, curb and gutter within limits of gutter depression and incidentals and for doing all the work involved complete in place and no additional compensation will be allowed.

TP19. RELOCATE MAILBOX

The work under this item shall include all labor, material and equipment required to relocate the existing mailbox per United States Postal Service (USPS) mailbox location standards. The mailbox must be set back 6 to 8 inches from the front face of the curb and must be at a vertical height of 41 to 45 inches from the road surface. Existing mailboxes that do not meet these requirements must be relocated before the new sidewalk is poured.



Payment: The contract unit price bid per **each** for the item “RELOCATE MAILBOX” shall include full compensation for furnishing all labor, materials, tools, equipment, and for doing all the work involved complete in place and no additional compensation will be allowed.

TP20. RELOCATE CANDLESTICK LIGHT POLE

The work under this item shall include all labor, material and equipment required to relocate the existing candlestick light pole and associated electrical box. Candlestick light poles are owned and maintained by the City of Beaumont. The candlestick light pole shall be set behind the sidewalk where possible per County of Riverside Standards. Where this is not possible, the light pole shall be set 18-inches behind the curb face and the sidewalk shall go behind the pole per County of Riverside Standards (Standard Drawing 400). The associated electrical boxes shall also be moved behind the sidewalk where possible; or adjusted to be flush with the new sidewalk surface.

Payment: The contract unit price bid per **each** for the item “RELOCATE CANDLESTICK LIGHT POLE” shall include full compensation for furnishing all labor, materials, tools, equipment, and for doing all the work involved complete in place and no additional compensation will be allowed.

TP21. ADJUST WATER SERVICE METER BOX ELEVATION

The work under this item shall include all labor, material and equipment required to adjust the elevation of the water service meter box. Meter boxes are owned and maintained by the Beaumont Cherry Valle Water District. For all water service meter boxes that conflict with the proposed sidewalk installation; the elevation of the existing meter boxes shall be adjusted to be flush with the new sidewalk surface.

The contractor is only allowed to adjust the meter box elevation and is not permitted to relocate the service or meter. If the meter boxes cannot be made flush simply by adjusting the box and lid elevations, and more work is needed such as adjusting the location of the meter and service; the contractor shall coordinate with Beaumont Cherry Valley Water District to adjust the meter and service location. The contractor is responsible for any coordination with the water district.

Payment: The contract unit price bid per **each** for the item “ADJUST WATER SERVICE METER BOX ELEVATION” shall include full compensation for furnishing all labor, materials, tools, equipment, and for doing all the work involved complete in place and no additional compensation will be allowed.



TP22. GUARANTEE

In addition to guarantees required elsewhere, the contractor shall and hereby does guarantee all Work for a period of one (1) year after the date of acceptance of the Work by the City and shall repair and replace any and all such Work, together with any other work which may be displaced in so doing that may prove defective in workmanship and/or materials within the one (1) year period from the date of acceptance, without expense whatsoever to the City, ordinary wear and tear and usual abuse or neglect excepted. In the event of failure to comply with the above mentioned conditions within five (5) days after being notified in writing, the City is hereby authorized to proceed to have the defects repaired and made good at the expense of the Contractor, who shall pay the cost and charges therefore immediately upon demand.



06 CONTRACT DRAWINGS
CITYWIDE SIDEWALK IMPROVEMENTS CIP R-24



CONTRACT DRAWINGS

All standard drawings and detailed provisions referenced in the Contract Documents shall be considered part of the contract drawings. These drawings include, but are not limited to, the following standard drawings and detailed provisions:

1. **City of Beaumont Public Works Standard Drawings:** latest standards available at <https://www.beaumontca.gov/1236/Standards>
2. **County of Riverside Standards and Specifications (Ordinance 461):** latest edition available at: <https://rctlma.org/trans/Land-Development/Road-Standards>)
3. **County of Riverside Flood Control and Water Conservation District Standard Drawings:** latest edition available at: <http://content.rcflood.org/downloads/Standard%20Drawings/@@Standard%20Drawings%2007102019.pdf>)
4. **Caltrans Standard Plans and Caltrans Revised Standard Plans:** latest edition available at: <https://dot.ca.gov/programs/design/ccs-standard-plans-and-standard-specifications>)
5. **Greenbook Standard Specifications for Public Works Construction:** latest standards available at: <https://www.bnibooks.com/products/standard-plans-for-public-works-construction-2021-edition>
6. **Construction Plans:** Improvement Plans for Citywide Sidewalk Improvement Project CIP R-24 are attached to this specification.



07 PUBLIC WORKS AGREEMENT

CITYWIDE SIDEWALK IMPROVEMENTS CIP R-24

**CITY OF BEAUMONT
PUBLIC WORKS AGREEMENT**

This PUBLIC WORKS AGREEMENT (“Agreement”) is made and effective _____, by and between the City of Beaumont, a municipal corporation (“CITY”), and , (“CONTRACTOR”), a California Corporation. In consideration of the mutual covenants and conditions set forth herein, the parties agree as follows:

FEDERAL FUNDING

This project is being financed with Community Development Block Grant funds from the U.S. Department of Housing and Urban Development (24 CFR Part 570) and subject to certain requirements including: compliance with Section 3 (24 CFR Part 75) Economic Opportunities requirements; payment of Federal Davis-Bacon prevailing wages; Federal Labor Standards Provisions (HUD 4010); Executive Order #11246; and others. Information pertaining to the Federal requirements is on file with the County of Riverside Department of Housing Homelessness Prevention and Workforce Solutions.

I. SCOPE OF WORK

The CONTRACTOR shall perform within the time set forth in Article 2 of this Agreement and shall furnish all labor, materials, equipment, tools, utility services, and transportation and perform and complete all work required in connection with the Community Recreation Center Interior Painting (hereinafter “Project”). CONTRACTOR’s Bid, dated _____, is attached hereto as Exhibit A and incorporated herein by this reference. The Scope of Work for the Project is set forth in the Invitation. In the event that any terms of the Bid are different from the Invitation for Bids, the Invitation for Bids shall control. Any additional terms in the Bid that purport to bind the City to any additional terms not contained in this Agreement and related attachments shall not be binding on the City.

By entering into this Agreement, CONTRACTOR acknowledges that there may be other contractors on the site whose work will be coordinated with that of its own. CONTRACTOR expressly warrants and agrees that it will cooperate with other contractors and will do nothing to delay, hinder, or interfere with the work of other separate contractors, the CITY, the Construction Manager, the Engineer, or utilities. CONTRACTOR also expressly agrees that, in the event its work is hindered, delayed, interfered with, or otherwise affected by a separate contractor, its sole remedy will be a direct action against the separate contractor. To the extent allowed by law, the CONTRACTOR will have no remedy, and hereby expressly waives any remedy against the CITY, the Construction Manager (if any), and the Engineer on account of delay, hindrance, interference, or other events.

II. TIME FOR PROJECT COMPLETION

All of CONTRACTOR's work on the Project shall be completed within durations established for the individual activities. All work shall commence ten (10) calendar days after receiving a written Notice of Award from the CITY or Construction Manager, if a Construction Manager is employed by CITY on the Project. CONTRACTOR shall refer to the invitations for bids, and Project Plans and Specifications, all of which, as set forth below, are incorporated herein by reference, for contractual obligations regarding individual activity durations.

III. THE CONTRACT SUM

The CITY shall pay to the CONTRACTOR for the performance of this Agreement, subject to any additions and deductions provided in the Project documents, the sum of _____ Dollars and ___ Cents (\$_____).

IV. PROGRESS PAYMENTS

Based upon Applications for Payment submitted to the Engineer by the CONTRACTOR and Certificates for Payment issued by the Engineer, the CITY shall make progress payments on account of the Contract Sum to the CONTRACTOR as provided in the General Conditions, which are fully incorporated into this Agreement by this reference.

This Agreement is subject to the provisions of Article 1.7 (commencing at Section 20104.50) of Division 2, Part 3 of the Public Contract Code regarding prompt payment of contractors by local governments. Article 1.7 mandates certain procedures for the payment of undisputed and properly submitted payment requests within 30 days after receipt, for the review of payment requests, for notice to Contractor of improper payment requests, and provides for the payment of interest on progress payment requests which are not timely made in accordance with that Article. This Agreement hereby incorporates the provisions of Article 1.7 as though fully set forth herein.

V. INDEMNITY, DEFENSE AND HOLD HARMLESS AGREEMENT

CONTRACTOR shall indemnify, defend with legal counsel approved by CITY, and hold harmless CITY, its officers, officials, employees and volunteers; and the County of Riverside, its Agencies, Districts, Special Districts and Departments, their respective directors, officers, Board of Supervisors, elected and appointed officials, employees, agents and representatives from and against all liability, loss, damage, expense, cost (including without limitation reasonable legal counsel fees, expert fees and all other costs and fees of litigation) of every nature arising out of or in connection with CONTRACTOR's negligence, recklessness or willful misconduct in the performance of work hereunder or its failure to comply with any of its obligations contained in this Agreement, except such loss or

damage which is caused by the sole or active negligence or willful misconduct of the CITY. Should conflict of interest principles preclude a single legal counsel from representing both CITY and CONTRACTOR, or should CITY otherwise find CONTRACTOR's legal counsel unacceptable, then CONTRACTOR shall reimburse the CITY its costs of defense, including without limitation reasonable legal counsels fees, expert fees and all other costs and fees of litigation. The CONTRACTOR shall promptly pay any final judgment rendered against the CITY (and its officers, officials, employees and volunteers) with respect to claims determined by a trier of fact to have been the result of the CONTRACTOR's negligent, reckless or wrongful performance. It is expressly understood and agreed that the foregoing provisions are intended to be as broad and inclusive as is permitted by the law of the State of California and will survive termination of this Agreement.

CONTRACTOR obligations under this section apply regardless of whether or not such claim, charge, damage, demand, action, proceeding, loss, stop notice, cost, expense, judgment, civil fine or penalty, or liability was caused in part or contributed to by an Indemnitee. However, without affecting the rights of CITY under any provision of this agreement, CONTRACTOR shall not be required to indemnify and hold harmless CITY for liability attributable to the active negligence of CITY, provided such active negligence is determined by agreement between the parties or by the findings of a court of competent jurisdiction. In instances where CITY is shown to have been actively negligent and where CITY active negligence accounts for only a percentage of the liability involved, the obligation of CONTRACTOR will be for that entire portion or percentage of liability not attributable to the active negligence of CITY.

VI. PREVAILING WAGES

- A. Contractor shall comply with all applicable laws and regulations relating to prevailing wages. Wage rates for this Project shall be in accordance with the "General Wage Determination Made By the Director of Industrial Relations Pursuant To California Labor Code, Part 7, Chapter 1, Article 2, Sections 1770, 1773 and 1773.1", for Riverside County. Wage rates shall conform with those posted at Beaumont City Hall and the Project site.
- B. The following Labor Code sections are hereby referenced and made a part of this Agreement:
 - 1. Section 1775 - Penalty for Failure to Comply with Prevailing Wage Rates.
 - 2. Section 1777.4 - Apprenticeship Requirements.
 - 3. Section 1777.5 - Apprenticeship Requirements.
 - 4. Section 1813 - Penalty for Failure to Pay Overtime.
 - 5. Sections 1810 and 1811 - Working Hour Restrictions.
 - 6. Section 1775 - Payroll Records.

7. Section 1773.8 - Travel and Subsistence Pay.

PREVAILING WAGES

Pursuant to Section 1773 of the Labor Code, the general prevailing wage rates, including the per diem wages applicable to the work, and for holiday and overtime work, including employer payments for health and welfare, pension, vacation, and similar purposes, in the County of Riverside in which the work is to be done, have been determined by the Director of the Department of Industrial Relations, State of California. These wages are set forth in the General Prevailing Wage Rates for this project, available from the California Department of Industrial Relations' Internet web site at www.dir.ca.gov. Future effective prevailing wage rates which have been predetermined, and are on file with the California Department of Industrial Relations, are referenced but not printed in the general prevailing wage rates.

The Federal minimum wage rate requirements, as predetermined by the U.S. Secretary of Labor, are set forth in the books issued for bidding purposes, referred to herein as Project Bid Documents (Special Federal Provisions), and in copies of this book which may be examined at the office described above where the project plans, special provisions, and proposal forms may be seen. Addenda to modify the minimum wage rates, if necessary, will be issued to holders of the Project Bid Documents.

VII. RECORD AUDIT

In accordance with Government Code, Section 8546.7, records of both the CITY and the CONTRACTOR shall be subject to examination and audit by the Auditor General for a period of three (3) years after final payment.

VIII. FINAL PAYMENT

Final payment, constituting the entire unpaid balance of the Agreement Sum, shall be paid by the CITY to the CONTRACTOR no sooner than thirty-five (35) days after a Notice of Completion has been recorded, unless otherwise stipulated in the Notice of Completion, provided the work has then been completed, the Agreement fully performed, and a final Certificate for Payment has been issued by the Engineer.

IX. CONTRACTOR'S FAILURE TO PROCURE COMPLETION OF PROJECT

In the event CONTRACTOR fails to furnish tools, equipment, or labor in the necessary quantity or quality, or fails to prosecute the work or any part thereof contemplated by this Agreement in a diligent and workmanlike manner, and if the CONTRACTOR for a period of three (3) calendar days after receipt of written

demand from CITY or its designated representative to do so, fails to furnish tools, equipment, or labor in the necessary quantity or quality, and to prosecute its work and all parts thereof in a diligent and workmanlike manner, or after commencing to do so within said three (3) calendar days, fails to continue to do so; then the CITY may exclude the CONTRACTOR from the premises, or any portion thereof, and take possession of said premises or any portion thereof, together with all material and equipment thereon, and may complete the work contemplated by this Agreement or any portion of said work, either by furnishing the tools, equipment, labor or material necessary, or by letting the unfinished portion of said work, or the portion taken over by the CITY to another contractor or by a combination of such methods. In any event, the procuring of the completion of said work, or the portion thereof taken over by the CITY, shall be a charge against the CONTRACTOR, and may be deducted from any money due or becoming due to CONTRACTOR from the CITY, or the CONTRACTOR shall pay the CITY the amount of said charge, or the portion thereof unsatisfied. The sureties, provided for under this Agreement shall become liable for payment should CONTRACTOR fail to pay in full any said cost incurred by the CITY.

X. INSURANCE

Prior to the beginning of and throughout the duration of the Project, CONTRACTOR and its subcontractors shall maintain insurance in conformance with the requirements set forth below. Attached hereto as Exhibit C are copies of Certificates of Insurance and the waiver of subrogation endorsement as required by Section 6.B.1. CONTRACTOR will use existing coverage to comply with these requirements. If that existing coverage does not meet the requirements set forth herein, CONTRACTOR agrees to amend, supplement or endorse the existing coverage to do so.

CONTRACTOR acknowledges that the insurance coverage and policy limits set forth in this section constitute the minimum amount of coverage required. Any insurance proceeds available to CONTRACTOR or its subcontractors in excess of the limits and coverage identified in this Agreement and which is applicable to a given loss, claim or demand, will be equally available to CITY.

A. Types of Insurance

Without limiting CONTRACTOR's indemnification of CITY, and prior to commencement of Work, CONTRACTOR shall obtain, provide and maintain at its own expense during the term of this Agreement, policies of insurance of the type and amounts described below and in a form satisfactory to CITY:

- 1. General liability insurance.** CONTRACTOR shall maintain commercial general liability insurance with coverage at least as broad as Insurance Services Office form CG 00 01, in an amount not less than \$1,000,000 per occurrence, \$2,000,000 general aggregate, for

bodily injury, personal injury, and property damage, and a \$2,000,000 completed operations aggregate. The policy must include contractual liability that has not been amended. Any endorsement restricting standard ISO “insured contract” language will not be accepted.

2. **Automobile liability insurance.** CONTRACTOR shall maintain automobile insurance at least as broad as Insurance Services Office form CA 00 01 covering bodily injury and property damage for all activities of the CONTRACTOR arising out of or in connection with Work to be performed under this Agreement, including coverage for any owned, hired, non-owned or rented vehicles, in an amount not less than \$1,000,000 combined single limit for each accident.

3. **Umbrella or excess liability insurance.** If CONTRACTOR is using umbrella coverage to meet part of its liability insurance requirements under Paragraph 1 of this Section, CONTRACTOR shall obtain and maintain an umbrella or excess liability insurance that will provide bodily injury, personal injury, completed operations and property damage liability coverage at least as broad as the primary coverages set forth above, including commercial general liability and employer’s liability. Such policy or policies shall include the following terms and conditions:
 - A drop down feature requiring the policy to respond in the event that any primary insurance that would otherwise have applied proves to be uncollectable in whole or in part for any reason;
 - Pay on behalf of wording as opposed to reimbursement;
 - Concurrence of effective dates with primary policies;
 - Policies shall “follow form” to the underlying primary policies; and
 - Insureds under primary policies shall also be insureds under the umbrella or excess policies.

4. **Workers’ compensation insurance.** CONTRACTOR shall maintain Workers’ Compensation Insurance (Statutory Limits) and Employer’s Liability Insurance (with limits of at least \$1,000,000) for CONTRACTOR’s employees in accordance with the laws of the State of California, Section 3700 of the Labor Code. In addition, CONTRACTOR shall require each subcontractor to similarly maintain Workers’ Compensation Insurance and Employer’s Liability Insurance in accordance with the laws of the State of California, Section 3700 for all of the subcontractor’s employees.

CONTRACTOR shall submit to CITY, along with the certificate of insurance, a Waiver of Subrogation endorsement in favor of CITY, its officers, agents, employees and volunteers.

- 5. Pollution liability insurance.** Environmental Impairment Liability Insurance shall be written on a CONTRACTOR's Pollution Liability form or other form acceptable to CITY providing coverage for liability arising out of sudden, accidental and gradual pollution and remediation. The policy limit shall be no less than \$1,000,000 dollars per claim and in the aggregate. All activities contemplated in this Agreement shall be specifically scheduled on the policy as "covered operations." The policy shall provide coverage for the hauling of waste from the project site to the final disposal location, including non-owned disposal sites.

Products/completed operations coverage shall extend a minimum of three (3) years after project completion. Coverage shall be included on behalf of the insured for covered claims arising out of the actions of independent contractors. If the insured is using subcontractors, the Policy must include work performed "by or on behalf" of the insured. Policy shall contain no language that would invalidate or remove the insurer's duty to defend or indemnify for claims or suits expressly excluded from coverage. Policy shall specifically provide for a duty to defend on the part of the insurer. The CITY, its officials, officers, agents, and employees, shall be included as insureds under the policy.

- 6. Builder's risk insurance.** Upon commencement of construction and with approval of CITY, CONTRACTOR shall obtain and maintain builder's risk insurance for the entire duration of the Project until only the CITY has an insurable interest. The Builder's Risk coverage shall include the coverages as specified below.

The named insureds shall be CONTRACTOR and CITY, including its officers, officials, employees, and agents. All Subcontractors (excluding those solely responsible for design Work) of any tier and suppliers shall be included as additional insureds as their interests may appear. CONTRACTOR shall not be required to maintain property insurance for any portion of the Project following transfer of control thereof to CITY. The policy shall contain a provision that all proceeds from the builder's risk policy shall be made payable to the CITY. The CITY will act as a fiduciary for all other interests in the Project.

Policy shall be provided for replacement value on an "all risk" basis for the completed value of the project. There shall be no coinsurance penalty or provisional limit provision in any such policy. Policy must include: (1) coverage for any ensuing loss from faulty workmanship, Nonconforming Work, omission or deficiency in design or specifications; (2) coverage against machinery accidents and operational testing; (3) coverage for removal of debris, and insuring the buildings, structures, machinery, equipment, materials, facilities,

fixtures and all other properties constituting a part of the Project; (4) Ordinance or law coverage for contingent rebuilding, demolition, and increased costs of construction; (5) transit coverage (unless insured by the supplier or receiving contractor), with sub-limits sufficient to insure the full replacement value of any key equipment item; (6) Ocean marine cargo coverage insuring any Project materials or supplies, if applicable; (7) coverage with sub-limits sufficient to insure the full replacement value of any property or equipment stored either on or off the Site or any staging area. Such insurance shall be on a form acceptable to CITY to ensure adequacy of terms and sublimits and shall be submitted to the CITY prior to commencement of construction.

B. Other provisions or requirements

- 1. Proof of insurance.** CONTRACTOR shall provide certificates of insurance to CITY as evidence of the insurance coverage required herein, along with a waiver of subrogation endorsement for workers' compensation. Insurance certificates and endorsements must be approved by CITY's risk manager prior to commencement of performance. Current certification of insurance shall be kept on file with CITY at all times during the term of this contract. CITY reserves the right to require complete, certified copies of all required insurance policies, at any time.
- 2. Duration of coverage.** CONTRACTOR shall procure and maintain for the duration of the contract insurance against claims for injuries to persons or damages to property, which may arise from or in connection with the performance of the Work hereunder by CONTRACTOR, his agents, representatives, employees or subcontractors. CONTRACTOR must maintain general liability and umbrella or excess liability insurance for as long as there is a statutory exposure to completed operations claims. CITY and its officers, officials, employees, and agents shall continue as additional insureds under such policies.
- 3. Primary/noncontributing.** Coverage provided by CONTRACTOR shall be primary and any insurance or self-insurance procured or maintained by CITY shall not be required to contribute with it. The limits of insurance required herein may be satisfied by a combination of primary and umbrella or excess insurance. Any umbrella or excess insurance shall contain or be endorsed to contain a provision that such coverage shall also apply on a primary and non-contributory basis for the benefit of CITY before the CITY's own insurance or self-insurance shall be called upon to protect it as a named insured.

- 4. CITY's rights of enforcement.** In the event any policy of insurance required under this Agreement does not comply with these requirements or is canceled and not replaced, CITY has the right but not the duty to obtain the insurance it deems necessary and any premium paid by CITY will be promptly reimbursed by CONTRACTOR or CITY will withhold amounts sufficient to pay premium from CONTRACTOR payments. In the alternative, CITY may cancel this Agreement.
- 5. Acceptable insurers.** All insurance policies shall be issued by an insurance company currently authorized by the Insurance Commissioner to transact business of insurance or is on the List of Approved Surplus Line Insurers in the State of California, with an assigned policyholders' Rating of A- (or higher) and Financial Size Category Class VII (or larger) in accordance with the latest edition of Best's Key Rating Guide, unless otherwise approved by the CITY's risk manager.
- 6. Waiver of subrogation.** All insurance coverage maintained or procured pursuant to this agreement shall be endorsed to waive subrogation against CITY, its elected or appointed officers, agents, officials, employees and volunteers or shall specifically allow CONTRACTOR or others providing insurance evidence in compliance with these specifications to waive their right of recovery prior to a loss. CONTRACTOR hereby waives its own right of recovery against CITY, and shall require similar written express waivers and insurance clauses from each of its subconsultants.
- 7. Enforcement of contract provisions (non estoppel).** CONTRACTOR acknowledges and agrees that any actual or alleged failure on the part of the CITY to inform CONTRACTOR of non-compliance with any requirement imposes no additional obligations on the CITY nor does it waive any rights hereunder.
- 8. Requirements not limiting.** Requirements of specific coverage features or limits contained in this Section are not intended as a limitation on coverage, limits or other requirements, or a waiver of any coverage normally provided by any insurance. Specific reference to a given coverage feature is for purposes of clarification only as it pertains to a given issue and is not intended by any party or insured to be all inclusive, or to the exclusion of other coverage, or a waiver of any type. If the CONTRACTOR maintains higher limits than the minimums shown above, the CITY requires and shall be entitled to coverage for the higher limits maintained by the CONTRACTOR. Any available insurance proceeds in excess of the specified minimum limits of insurance and coverage shall be available to the CITY.

- 9. Notice of cancellation.** CONTRACTOR agrees to oblige its insurance agent or broker and insurers to provide to CITY with a thirty (30) day notice of cancellation (except for nonpayment for which a ten (10) day notice is required) or nonrenewal of coverage for each required coverage.
- 10. Additional insured status.** General liability policies shall provide or be endorsed to provide that CITY and its officers, officials, employees, agents, and volunteers shall be additional insureds under such policies. This provision shall also apply to any excess/umbrella liability policies.
- 11. Prohibition of undisclosed coverage limitations.** None of the coverages required herein will be in compliance with these requirements if they include any limiting endorsement of any kind that has not been first submitted to CITY and approved of in writing.
- 12. Separation of insureds.** A severability of interests provision must apply for all additional insureds ensuring that CONTRACTOR's insurance shall apply separately to each insured against whom claim is made or suit is brought, except with respect to the insurer's limits of liability. The policy(ies) shall not contain any cross-liability exclusions.
- 13. Pass through clause.** CONTRACTOR agrees to ensure that its subconsultants, subcontractors, and any other party involved with the project who is brought onto or involved in the project by CONTRACTOR, provide the same minimum insurance coverage and endorsements required of CONTRACTOR. CONTRACTOR agrees to monitor and review all such coverage and assumes all responsibility for ensuring that such coverage is provided in conformity with the requirements of this section. CONTRACTOR agrees that upon request, all agreements with consultants, subcontractors, and others engaged in the project will be submitted to CITY for review.
- 14. CITY's right to revise requirements.** The CITY reserves the right at any time during the term of the contract to change the amounts and types of insurance required by giving the CONTRACTOR a ninety (90) day advance written notice of such change. If such change results in substantial additional cost to the CONTRACTOR, the CITY and CONTRACTOR may renegotiate CONTRACTOR's compensation.
- 15. Self-insured retentions.** Any self-insured retentions must be declared to and approved by CITY. CITY reserves the right to require that self-insured retentions be eliminated, lowered, or replaced by a deductible.

Self-insurance will not be considered to comply with these specifications unless approved by CITY.

16. Timely notice of claims. CONTRACTOR shall give CITY prompt and timely notice of claims made or suits instituted that arise out of or result from CONTRACTOR's performance under this Agreement, and that involve or may involve coverage under any of the required liability policies.

17. Additional insurance. CONTRACTOR shall also procure and maintain, at its own cost and expense, any additional kinds of insurance, which in its own judgment may be necessary for its proper protection and prosecution of the Work.

XI. CONTRACTOR'S LICENSE

CONTRACTOR must possess at the time of commencing work and throughout the Project duration, a Contractor's License, issued by the State of California, which is current and in good standing. CONTRACTOR shall ensure that any subcontractor working on the Project possesses at the time of commencing work and throughout the Project duration, a Contractor's License, issued by the State of California, which is current and in good standing.

XII. REGISTRATION REQUIREMENTS

A. Pursuant to Section 1771.1(a) of the Labor Code:

"A contractor or subcontractor shall not be qualified to bid on, be listed in a bid proposal, subject to the requirements of Section 4104 of the Public Contract Code, or engage in the performance of any contract for public work, as defined in this chapter, unless currently registered and qualified to perform public work pursuant to Section 1725.5. It is not a violation of this section for an unregistered contractor to submit a bid that is authorized by Section 7029.1 of the Business and Professions Code or by Section 10164 or 20103.5 of the Public Contract Code, provided the contractor is registered to perform public work pursuant to Section 1725.5 at the time the contract is awarded."

B. CONTRACTOR must be registered with the Department of Industrial Relations (DIR) of the State of California in order to be eligible to work on public works projects. CONTRACTOR must ensure registration with the DIR that is active and in good standing.

C. No contractor or subcontractor may be listed on a bid proposal for a public works project (submitted on or after March 1, 2015) unless registered with the Department of Industrial Relations pursuant to Labor Code section 1725.5 [with

limited exceptions from this requirement for bid purposes only under Labor Code section 1771.1(a)].

No contractor or subcontractor may be awarded a contract for public work on a public works project (awarded on or after April 1, 2015) unless registered with the Department of Industrial Relations pursuant to Labor Code section 1725.5.

This project is subject to compliance monitoring and enforcement by the Department of Industrial Relations.

D. The CONTRACTOR is not subject to public works requirements (including registration with the DIR) if the public works project is under \$1,000, unless the CITY knows that the same CONTRACTOR will be awarded total project costs in excess of \$1,000 for a given year.

XIII. CORPORATION IN GOOD STANDING

If CONTRACTOR is a corporation, the undersigned hereby represents and warrants that the corporation is duly incorporated and in good standing in the State of California, and that David Van Dyke whose title is President is authorized to act for and bind the corporation.

XIV. PROVISIONS REQUIRED BY LAW

Each and every provision of law and clause required by law to be inserted in this Agreement shall be deemed to be inserted herein and the Agreement shall be read and enforced as though it were included herein, and if through mistake or otherwise any such provision is not inserted, or is not currently inserted, then upon application of either party the Agreement shall forthwith be physically amended to make such insertion or correction.

XV. SUBSURFACE HAZARDOUS MATERIALS

A. In the event trenches or other excavations extend deeper than four (4) feet below the surface, the CONTRACTOR shall promptly, and before the following conditions are disturbed, notify the CITY in writing of any:

1. Material that the CONTRACTOR believes may be material that is hazardous waste, as defined in Section 25117 of the Health and Safety Code that is required to be removed to a Class I, Class II or Class III disposal site in accordance with the provisions of existing law.
2. Subsurface or latent physical conditions at the site differing from those indicated.
3. Unknown physical conditions at the site of any unusual nature, different materially from those ordinarily encountered and generally

recognized as inherent in the Work or the character provided for in the CONTRACT.

- B. Upon receipt of said notification the CITY will investigate the conditions, and if it finds that the conditions do materially so differ, or do involve hazardous waste, and cause a decrease or increase in the CONTRACTOR's cost of or the time required for performance of any part of the work, the CITY will issue a change order under the procedures described in the General Conditions.
- C. In the event that a dispute arises between the CITY and the CONTRACTOR whether the conditions materially differ, or involve hazardous waste or cause a decrease or increase in the CONTRACTOR's cost of or time required for performance of any part of the work, the CONTRACTOR shall not be excused from any scheduled completion date provided for by the Agreement, but shall proceed with all work to be performed under the Agreement. The CONTRACTOR shall retain any and all rights provided either by Agreement or by law which pertain to the resolution of disputes and protests between the contracting parties.

XVI. COMPONENT PARTS OF THE CONTRACT

This Agreement entered into consists of the following CONTRACT DOCUMENTS, all of which are component parts of the Agreement as if herein set out in full or attached hereto:

- | | |
|--|---|
| <input type="checkbox"/> Notice Inviting Bids | <input type="checkbox"/> Bid Bond |
| <input type="checkbox"/> Scope of Work Summary | <input type="checkbox"/> Information Required of Bidder |
| <input type="checkbox"/> Information for Bidders | <input type="checkbox"/> Construction Services Agreement |
| <input type="checkbox"/> Bid Form | <input type="checkbox"/> Certificate Regarding Worker's |
| <input type="checkbox"/> Non-Collusion Affidavit | <input type="checkbox"/> Compensation |
| <input type="checkbox"/> Site Visit Certification | <input type="checkbox"/> Drug-free Workplace Certification |
| <input type="checkbox"/> Faithful Performance Bond | <input type="checkbox"/> Plans and Specifications |
| <input type="checkbox"/> Labor and Materials Payment | <input type="checkbox"/> Addenda |
| <input type="checkbox"/> Bond | <input type="checkbox"/> Drawings |
| <input type="checkbox"/> General and Supplemental | <input type="checkbox"/> Change Orders |
| <input type="checkbox"/> Conditions | <input type="checkbox"/> Shop Drawing Transmittals |
| <input type="checkbox"/> Special Conditions | <input type="checkbox"/> Contractor's Certificate Regarding |
| <input type="checkbox"/> Project Construction Schedule | <input type="checkbox"/> Non-Asbestos Containing |
| <input type="checkbox"/> Proposed Subcontractors | <input type="checkbox"/> Materials |

All of the above-named CONTRACT DOCUMENTS are intended to be complementary. Work required by one of the above-named CONTRACT DOCUMENTS and not by others shall be done as if required by all.

Special Federal Requirements

1. Contractor and Owner do hereby acknowledge that this project will be partially or fully funded with Community Development Block Grant (CDBG) funds [24 CFR 570] and is therefore subject to applicable Federal procurement, labor, environmental, equal opportunity, and other regulations.

2. Contractor shall maintain and keep books and records on a current basis, recording all transactions pertaining to this agreement in a form in accordance with generally acceptable accounting principles. Said books and records shall be made available to the County, the State of California, the Federal government, and to any authorized representative thereof for the purposes of audit at all reasonable times and places. All such books and records shall be retained for such periods of time as required by law, provided, however, notwithstanding any shorter periods of

retention, all books, records, and supporting detail shall be retained for a period of at least four (4) years after the expiration of the term of this Agreement.

3. Contractor shall comply with the Davis-Bacon Fair Labor Standards Act (40 U.S.C.A. Section 3141-3148) and the implementation regulations thereof. Contractor shall comply with the U.S. Department of Housing and Urban Development's Federal Labor Standards Provisions (HUD 4010). Contractor acknowledges that the applicable Wage Determination for this project is:

General Decision Number: CA _____

Modification Number: _____

Date: _____

4. Section 3 Compliance: The Contractor hereby acknowledges that this federally-funded project is subject to Section 3 of the Housing and Urban Development Act of 1968 [12 U.S.C. 1701u and 24 CFR Part 75] and agrees to the following:

A. The work to be performed under this contract is subject to the requirements of Section 3 of the Housing and Urban Development Act of 1968, as amended, 12 U.S.C. 1701u (Section 3). The purpose of Section 3 is to ensure that employment and other economic opportunities generated by HUD assistance or HUD-assisted projects covered by Section 3, shall, to the greatest extent feasible, be directed to low- and very low-income persons, particularly persons who are recipients of HUD assistance for housing.

B. The parties to this contract agree to comply with HUD's regulations in 24 CFR Part 75, which implement Section 3. As evidenced by their execution of this contract, the parties to this contract certify that they are under no contractual or other impediment that would prevent them from complying with the Part 75 regulations.

C. The contractor agrees to send to each labor organization or representative of workers with which the contractor has a collective bargaining agreement or other understanding, if any, a notice advising the labor organization or workers' representative of the contractor's commitments under this Section 3 clause, and will post copies of the notice in conspicuous places at the work site where both employees and applicants for training and employment positions can see the notice. The notice shall describe the Section 3 preference, shall set forth minimum number and job titles subject to hire, availability of apprenticeship and training positions, the qualifications for each; and the name and location of the person(s) taking applications for each of the positions; and the anticipated date the work shall begin.

D. The contractor agrees to include this Section 3 clause in every subcontract subject to compliance with regulations in 24 CFR Part 75, and agrees to take appropriate action, as provided in an applicable provision of the subcontract or in this Section 3 clause, upon a finding that the subcontractor is in violation of the regulations in 24 CFR Part 75. The contractor will not subcontract with any subcontractor where the contractor has notice or knowledge that the subcontractor has been found in violation of the regulations in 24 CFR Part 75.

E. The contractor will certify that any vacant employment positions, including

training positions, that are filled (1) after the contractor is selected but before the contract is executed, and (2) with persons other than those to whom the regulations of 24 CFR Part 75 require employment opportunities to be directed, were not filled to circumvent the contractor's obligations under 24 CFR Part 75.

F. Noncompliance with HUD's regulations in 24 CFR Part 75 may result in sanctions, termination of this contract for default, and debarment or suspension from future HUD assisted contracts.

G. With respect to work performed in connection with Section 3 covered Indian housing assistance, Section 7(b) of the Indian Self-Determination and Education Assistance Act (25 U.S.C. 450e) also applies to the work to be performed under this contract. Section 7(b) requires that to the greatest extent feasible (i) preference and opportunities for training and employment shall be given to Indians, and (ii) preference in the award of contracts and subcontracts shall be given to Indian organizations and Indian-owned Economic Enterprises. Parties to this contract that are subject to the provisions of Section 3 and Section 7(b) agree to comply with Section 3 to the maximum extent feasible, but not in derogation of compliance with Section 7(b).

Additional Federal Requirements

Whereas, the work under this Agreement is subject to applicable Federal, State, and local laws and regulations, including but not limited to the regulations pertaining to the Community Development Block Grant program (24 CFR Part 570) and the Uniform Administrative Requirement, Cost Principles, and Audit Requirements for Federal

Awards (2 CFR Part 200). Contractor, sub-contractors, Consultants, and sub-consultants agree to comply with, and are subject to, all applicable requirements as follows:

1. Equal Employment Opportunity - Compliance with Executive Order 11246 of September 24, 1965, entitled "Equal Employment Opportunity", as amended by Executive Order 11375 of October 13, 1967, and as supplemented in Department of Labor regulations (41 CFR Part 60). The Contractor/Consultant will not discriminate against any employee or applicant for employment because of race, color, religion, sex, sexual orientation, general identity or national origin. Contractor/Consultant will ensure that all qualified applicants will receive consideration for employment without regard to race, color, religion, sex sexual orientation, general identity or national origin. The Contractor/Consultant will take affirmative action to ensure that applicants are employed and the employees are treated during employment, without regard to their race color, religion, sex, sexual orientation, general identity or national origin. Such actions shall include, but are not limited to, the following: employment, up-grading, demotion, or transfer; recruitment or recruitment advertising; rates of pay or other forms of compensation; and selection for training, including apprenticeship. The Contractor/Consultant agrees to post in a conspicuous place, available to employees and applicants for employment, notices to be provided by the County setting forth the provisions of this non-discriminating clause.

2. Copeland "Anti-Kickback" Act (18 U.S.C. 874 and 40 U.S.C.A. Section 3145): All contracts and subgrants in excess of \$2,000 for construction or repair awarded by recipients and subrecipients shall include a provision for compliance with the Copeland "Anti-Kickback" Act (18 U.S.C. 874), as supplemented by Department of Labor regulations (29 CFR Part 3, "Contractors and Subcontractors on Public Building or Public Work Financed in Whole or in Part by Loans or Grants from the United States"). The Act provides that each contractor or subrecipient shall be prohibited from inducing, by any means, any person employed

in the construction, completion, or repair of public work, to give up any part of the compensation to which he is otherwise entitled. The recipient shall report all suspected or reported violations to HUD.

3. Davis-Bacon Act, as amended (40 U.S.C.A. Section 3141-3148): When required by Federal program legislation, all construction contracts awarded by the recipients and subrecipients of more than \$2000 shall include a provision for compliance with the Davis-Bacon Act (40 U.S.C. A. Section 3141-3148) and as supplemented by Department of Labor regulations (29 CFR Part 5, "Labor Standards Provisions Applicable to Contracts Governing Federally Financed and Assisted Construction"). Under the Davis Bacon Act, contractors shall be required to pay wages to laborers and mechanics at a rate not less than the minimum wages specified in a wage determination made by the U.S. Secretary of Labor. In addition, contractors shall be required to pay wages not less than once a week. The recipient shall place a copy of the current prevailing wage determination issued by the U.S. Department of Labor in each solicitation and the award of a contract shall be conditioned upon the acceptance of the

wage determination. The recipient shall report all suspected or reported violations to HUD.

4. Contract Work Hours and Safety Standards Act (40 U.S.C.A. 32701 through 3708): Where applicable, all contracts awarded by recipients in excess of \$2,000 for construction contracts and in excess of \$2,500 for other contracts that involve the employment of mechanics or laborers shall include a provision for compliance with the Contract Work Hours and Safety Standards (40 U.S.C.A. 32701–3708), as supplemented by Department of Labor Regulations (29 CFR Part 5). Under Section 40 U.S.C.A. 3702, each contractor shall be required to compute the wages of every mechanic and laborer on the basis of a standard workweek of 40 hours. Work in excess of the standard workweek is permissible provided that the worker is compensated at a rate of not less than 1 1/2 times the basic rate of pay for all hours worked in excess of 40 hours in the workweek. 40 U.S.C.A. 3704 of the Act is applicable to construction work and provides that no laborer or mechanic shall be required to work in surroundings or under working conditions which are unsanitary, hazardous or dangerous. These requirements do not apply to the purchases of supplies or materials or articles ordinarily available on the open market, or contracts for transportation or transmission of intelligence.

5. Rights to Inventions Made Under a Contract or Agreement— Contracts or agreements for the performance of experimental, developmental, or research work shall provide for the rights of the Federal Government and the recipient in any resulting invention in accordance with 37 CFR part 401, “Rights to Inventions Made by Nonprofit Organizations and Small Business Firms Under Government Grants, Contracts and Cooperative Agreements,” and any implementing regulations issued by HUD.

6. Rights to Data and Copyrights – Contractors and consultants agree to comply with all applicable provisions pertaining to the use of data and copyrights pursuant to 48 CFR Part 27.404-3, Federal Acquisition Regulations (FAR).

7. Air Pollution Prevention and Control (formally known as the Clean Air Act) (42 U.S.C.A. 7401 et seq.) and the Federal Water Pollution Control Act (33 U.S.C.A. Section 1251 et seq.), as amended:—Contracts and subgrants of amounts in excess of \$100,000 shall contain a provision that requires the recipient to agree to comply with all applicable standards, orders or regulations issued pursuant to the Clean Air Act (42 U.S.C. 7401 et seq.) and the Federal Water Pollution Control Act as amended (33 U.S.C.A. 1251 et seq.). Violations shall be reported to HUD and the Regional Office of the Environmental Protection Agency (EPA).

8. Byrd Anti-Lobbying Amendment (31 U.S.C.A. 1352)— Contractors who apply or bid for an award of \$100,000 or more shall file the required certification. Each tier certifies to the tier above that it will not and has not used Federal appropriated funds to pay any person or organization for influencing or attempting to influence an officer or employee of any agency, a member of Congress, officer or employee of Congress, or an employee of a member of Congress in connection with obtaining any Federal contract, grant or any other award covered by 31 U.S.C. 1352. Each tier shall also disclose any

lobbying with non-Federal funds that takes place in connection with obtaining any Federal award. Such disclosures are forwarded from tier to tier up to the recipient.

9. Debarment and Suspension (Executive Orders (E.O. s) 12549 and 12689)—No contract shall be made to parties listed on the General Services Administration's List of Parties Excluded from Federal Procurement or Nonprocurement Programs in accordance with E.O.s 12549 and 12689, "Debarment and Suspension," as set forth at 24 CFR part 2424. This list contains the names of parties debarred, suspended,

or otherwise excluded by agencies, and contractors declared ineligible under statutory or regulatory authority other than E.O. 12549. Contractors with awards that exceed the small purchase threshold shall provide the required certification regarding its exclusion status and that of its principal employees.

10. Drug-Free Workplace Requirements— The Anti-Drug Abuse Act of 1988 (41 U.S.C.A. Section 8101-8103) requires grantees (including individuals) of federal agencies, as a prior condition of being awarded a grant, to certify that they will provide drug-free workplaces. Each potential recipient must certify that it will comply with drug-free workplace requirements in accordance with the Act and with HUD's rules at 24 CFR part 2425.

11. Access to Records and Records Retention: The Consultant or Contractor, and any sub-consultants or sub-contractors, shall allow all duly authorized Federal, State, and/or County officials or authorized representatives access to the work area, as well as all books, documents, materials, papers, and records of the Consultant or Contractor, and any sub-consultants or sub-contractors, that are directly pertinent to a specific program for the purpose of making audits, examinations, excerpts, and transcriptions. The Consultant or Contractor, and any sub-consultants or sub-contractors, further agree to maintain and keep such books, documents, materials, papers, and records, on a current basis, recording all transactions pertaining to this agreement in a form in accordance with generally acceptable accounting principles. All such books and records shall be retained for such periods of time as required by law, provided, however, notwithstanding any shorter periods of retention, all books, records, and supporting detail shall be retained for a period of at least four (4) years after the expiration of the term of this Agreement.

12. Federal Employee Benefit Clause: No member of or delegate to the congress of the United States, and no Resident Commissioner shall be admitted to any share or part of this agreement or to any benefit to arise from the same.

13. Energy Efficiency: Mandatory standards and policies relating to energy efficiency which are contained in the State energy conservation plan issued in compliance with the Energy Policy and Conservation Act (Pub. L. 94A 163, Dec. 22, 1975; 42 U.S.C.A. Section 6201, et. seq., 89 Stat. 871).

14. Procurement of Recovered Materials (2 CFR 200.322.) A non-Federal entity that is a state agency or agency of a political subdivision of a state and its contractors must comply with 42 U.S.C. Section 6962 of the Solid Waste Disposal Act (42 U.S.C.A.

Section 6901, et seq.), as amended by the Resource Conservation and Recovery Act. The requirements of Section 6002 include procuring only items designated in guidelines of the Environmental Protection Agency (EPA) at 40 CFR part 247 that contain the highest percentage of recovered materials practicable, consistent with maintaining a satisfactory level of competition, where the purchase price of the item exceeds \$10,000 or the value of the quantity acquired by the preceding fiscal year exceeded \$10,000; procuring solid waste management services in a manner that maximizes energy and resource recovery; and establishing an affirmative procurement program for procurement of recovered materials identified in the EPA guidelines.

15. Build America, Buy America (BABA) Act: The Grantee must comply with the requirements of the Build America, Buy America (BABA) Act, 41 USC 8301 note, and all applicable rules and notices, as may be amended, if applicable to the Grantee's infrastructure project. Pursuant to HUD's Notice, "Public Interest Phased Implementation Waiver for FY 2022 and 2023 of Build America, Buy America Provisions as Applied to Recipients of HUD Federal Financial Assistance" (88 FR 17001), any funds obligated by HUD on or after the applicable listed effective dates, are subject to BABA requirements, unless excepted by a waiver.

XVII. ENTIRE CONTRACT

This Agreement constitutes the entire contract of the parties. No other agreements or contracts, whether oral or written, pertaining to the work to be performed, exists between the parties. This Agreement can be modified only by an amendment in writing, signed by both parties.

[Signatures on following page.]

**SIGNATURE PAGE TO
CITY OF BEAUMONT
PUBLIC WORKS AGREEMENT**

CITY:

CITY OF BEAUMONT

By:

CONTRACTOR:

TSR Construction and Inspection

By: _____

Print Name: _____

Title: _____

**CITY OF BEAUMONT
PUBLIC WORKS AGREEMENT**

EXHIBIT "A"

INVITATION FOR BIDS

**CITY OF BEAUMONT
PUBLIC WORKS AGREEMENT**

EXHIBIT "B"

CONTRACTOR'S Bid

CITY OF BEAUMONT
PUBLIC WORKS AGREEMENT

EXHIBIT "C"

Insurance Certificates and Endorsements



08 APPENDICES

CITYWIDE SIDEWALK IMPROVEMENTS CIP R-24

ELM STREET - EAST SIDE 7th to 11th Street

Address	Description	Remove Exist. Driveway Approach	New Driveway Approach	Remove Large Tree	Remove Small Tree	Relocate Mail Box	Adjust Meter Box Elev.	Curb Inlet Catch Basin	Curb Ramp Type A	Curb Ramp Type B	Curb Ramp Type C	Detectable Warning Surface	Go behind SCE pole	Relocate Candle stick Light Pole	Remove & Replace Curb & Gutter (LF)	Relocate Hydrant / Blow-off	Relocate Air-Vac
715 Wellwood Ave	School. Steep grass. Elevation Cuts (2-3 ft), new retaining curb needed			3			1	2			1		1	2	150	2	1
814 Elm	Steep Grass. Elevation Cuts (2-3 ft), new retaining curb needed	1	1			1											
832 Elm	Steep Slope. Elevation Cuts (2-3 ft) very close to tree	1	1			1											
838 Elm	sloped dirt, elevation cuts (1-2 ft)	1	1			1											
860 Elm	sloped dirt, elevation cuts (1-2 ft)	1	1			1											
862 Elm	Elevation Cuts (6in - 1ft)		1			1											
844 Elm	Elevation Cuts (6in - 1ft)	1	1			1											
894 Elm	SCE Station, Existing Sidewalk, transition to parkway																
9th & Elm Curb Ramp (S)	Add DTW surface											1					
9th & Elm Curb Ramp (N)	Complete new curb ramb								1								
902 Elm	No driveway, nice & flat					1											
914 Elm	Flat. Dirt	1	1			1											
926 Elm	Flat dirt	1	1			1											
938 Elm	Steep sloped lot, elevation cuts (3-4 ft)	1	1	4		1							retaining curb in front of pole		40		
950 Elm	Remove pavers & Large tree stump, Elevation cuts (3 ft)		1			1											
952 Elm	Remove Existing Sidewalk (20 ft)	2	2			1											
986 Elm	Remove Existing Sidewalk (5 ft). Remove landscaping	1	1														
10th & Elm Curb Ramp (S)	Complete new curb ramp								1								
10th & Elm Curb Ramp (N)	Complete new curb ramp								1								
290 W 10th	flat grass															50	
1014 Elm	flat grass	1	1	1		1											
1026 Elm	Remove 6ft tall hedges and landscaping	2	2			1											
1040 Elm	already existing sidewalk	1	1														
1050 Elm	elevation cuts (6" to 1ft)	1	1			1										25	
1062 Elm	Flat, remove grass & landscape curbs					1											
1086 Elm	Remove landscaping (hedge, bricks, rose bushes)		2				2										
11th & Elm Curb Ramp (S)	Complete new curb ramp									1							
11th & Elm Curb Ramp (N)	Complete new curb ramp									1							

N CALIFORNIA AVE - WEST SIDE 9th to 11th Street

Address	Description	Remove Exist. Driveway Approach	New Driveway Approach	Remove Large Tree	Remove Small Tree	Relocate Mail Box	Adjust Meter Box Elev.	Curb Inlet Catch Basin	Curb Ramp Type A	Curb Ramp Type B	Curb Ramp Type C	Detectable Warning Surface	Go behind SCE Pole	Relocate Candle stick light Pole	New Curb & Gutter (LF)	Relocate Hydrant / Blow-off	Relocate Air-Vac
9th & California Curb Ramp (S)	New curb ramps, curb & gutter						1				2			1	50		
9th & California Curb Ramp (N)	New curb ramp, curb & gutter										2				50	1	
905 N California	Remove treets & large shrubs, asphalt driveway	1	1		3	2											
915 N California	Flat Dirt		1			1											
929 N California	Flat Dirt		2			1							1				
937 N California	Relocate wooden fence & shrub bush	1	1														
951 N California	Grass w/ 2 driveway approaches	2	2			1	1						1				
963 N California	Remove chainlink fence	1	1			1											
975 N California	Flat Grass	1	1			1											
987 N California	Sidewalk already existing	1	1														
10th & N California Curb Ramp (S)	add DW Surface											1					
10th & N California Curb Ramp (N)	Complete new curb ramp, gutter, spandrel								1						50		
100 W 10th St	sloped dirt (6" - 2ft cuts), remove trees			1	3												
1025 N California	sloped dirt (6" - 1ft cuts)	1	1														
1037 N California	sloped dirt (6" - 1ft cuts)	1	1			1							1				
1049 N California	Flat Grass	1	1			1											
1051 N California	Flat grass	1	1			1											
1073 N California	Flat Dirt	1	1			1											
1085 N California	Flat Dirt												1				
11th & N California Curb Ramp (S)	New ramp, go behind SCE guy wire										2					1	

EDGAR AVE - WEST SIDE 9th to 12th Street

Address	Description	Remove Exist. Driveway Approach	New Driveway Approach	Remove Large Tree	Remove Small Tree	Relocate Mail Box	Adjust Meter Box Elev.	Curb Inlet Catch Basin	Curb Ramp Type A	Curb Ramp Type B	Curb Ramp Type C	Detectable Warning Surface	Go behind SCE Pole	Relocate Candle stick light Pole	Remove & Replace Curb & Gutter (LF)	Relocate Hydrant / Blow-off	Relocate Air-Vac
9th & Edgar Curb Ramp (S)	Complete new Ramp, work around SCE pole									1	2			1			
9th & Edgar Curb Ramp (N)	Complete new curb ramp																
901 Edgar	Flat Dirt		1			1											
917 Edgar	Sloped Grass (6" - 1ft cuts), remove large bush		1			1											
921 Edgar	remove asphalt driveway	1	1														
927 Edgar	remove asphalt driveway	1	1														
949 Edgar	Remove asphalt driveway	1	1														
963 Edgar	Empty Lot																
973 Edgar	Flat gravel and rock scape	1	2														
187 E 10th St	Flat Grass (small section of existing sidewalk)	1	1														
10th & Edgar Curb Ramp (S)	New ramp, work around SCE pole and guy wire										2		1	1			
10th & Edgar Curb Ramp (N)	New ramp, fence removal									1							
182 E 10th St	Flat dirt, relocate chainlink fence, remove asphalt drivewa	1	1														
1017 Edgar	Sidewalk already existing	1	1														
1027 Edgar	flat dirt, remove asphalt driveway	1	1														
1037 Edgar	Flat Dirt		1														
1049 Edgar	Flat Dirt		1														
1061 Edgar	Remove shrub palms		2			1											
1073 Edgar	Flat Dirt, remove some desert shrubs: Bushers, and pavers	1	1														
1075 Edgar	Sloped Grass (6" - 1ft cuts), remove concrete steps, SCE pole												1				
11th & Edgar Curb Ramp (S)	New ramp, remove bushes								1								
11th & Edgar Curb Ramp (N)	New Ramp, remove wood fence, rockscape, work around SCE pole										2		1	1			
1101 Edgar	flat dirt, large bushes		1			1	1										
1105 Edgar	Flat Dirt		1			1											
1115 Edgar	Empty lot, already existing sidewalk	1	1														
1127 Edgar	Existing Sidewalk	1	1														
1129 Edgar	Flat Rockscape		1			1								1			
1131 Edgar	Existing Sidewalk	1	1			1											
1145 Edgar	Remove Rock scape & desert shrubs	1	1														
1147 Edgar	Already existing sidewalk																
E. Pearl & Edgar Curb Ramp (S)	Existing Curb Ramp																
E. Pearl & Edgar Curb Ramp (N)	New ramp, Remove chainlink fence, poplar tree, hydrant				1					1						1	
1151 Edgar	flat rockscape					1											
1153 Edgar	Flat Grass	1	1			1											
1159 Edgar	Flat Dirt	1	1			1											
1165 Edgar	Flat Dirt		2			1											
1173 Edgar	Flat Dirt	1	1			1											
1175 Edgar	Already Existing Sidewalk	1	1														
1179 Edgar	Flat Grass, remove asphalt drive approach	1	1			1											
1181 Edgar	Flat Dirt		1			1											
1185 Edgar	Flat Dirt, remove sidewalk pavers	1	1			1	1										
12th & Edgar Curb Ramp (S)	New Ramp, work around SCE pole, guy wire, SCE box										2		1	1			
12th & Edgar Curb Ramp (N)	New Ramp, remove large tree, chainlink fence			1						1							

EDGAR AVE - EAST SIDE 9th to 12th Street

Address	Description	Remove Exist. Driveway Approach	New Driveway Approach	Remove Large Tree	Remove Small Tree	Relocate Mail Box	Adjust Meter Box Elev.	Curb Inlet Catch Basin	Curb Ramp Type A	Curb Ramp Type B	Curb Ramp Type C	Detectable Warning Surface	Go behind SCE Pole	Relocate Candle stick light Pole	Repair Curb & Gutter (LF)	Relocate Hydrant / Blow-off	Relocate Air-Vac
9th & Edgar Curb Ramp (S)	Existing Type C Ramp																
9th & Edgar Curb Ramp (N)	Complete new curb ramp								1								
210 E 9th St	Sloped Dirt (1-2 ft cuts)																
928 Edgar	Sloped Grass (1 ft cuts)																
940 Edgar	Remove Existing Sidewalk (10 ft)	1	1														
950 Edgar	Flat Dirt		1														
962 Edgar	Flat Dirt, Remove Large Tree		1	1		1											
976 Edgar	Flat Dirt, Remove Large Tree		1	1									1				
986 Edgar	Flat Dirt, remove concrete panel and section of wooden picket fence																
10th & Edgar Curb Ramp (S)	complete new ramp, remove 2 trees				2					1							
10th & Edgar Curb Ramp (N)	new ramp, remove tree stump								1							1	
1014 Edgar	Flat Grass, remove small trees and bushes				2												
1026 Edgar	Sidewalk Existing	1	1														
1038 Edgar	Sidewalk Existing	1	1														
1054 Edgar	Sidewalk Existing	2	2			2											
1062 Edgar	Flat Dirt		1														
1070 Edgar	Flat Dirt		1														
1086 Edgar	Remove Existing Sidewalk (10 ft)	1	1														
11th & Edgar Curb Ramp (S)	Ramp Existing																
11th & Edgar Curb Ramp (N)	complete new ramp								1								
204 E 11th St	Sloped Dirt (1 - 2ft cuts), remove 2 trees			2													
201 Merry Ln	Flat Grass, remove tree, small brick walls, and concrete panel				1												
Merry & Edgar Curb Ramp (S)	complete new curb ramp								1								
Merry & Edgar Curb Ramp (N)	new ramp, relocate chainlink fence, work around SCE box									1							
202 Merry Ln	flat dirt, relocate chain link fence																
1132 Edgar	flat rock scape, remove existing sidewalk (10 ft)	1	1			1							1				
1140 Edgar	sloped grass (6" cuts), remove landscape bricks, shrubs, small palms	1	1		1								1				
1148 Edgar	Flat Dirt	1	1														
1152 Edgar	Existing Sidewalk	2	2										1				
1154 Edgar	Remove Existing Sidewalk (30 ft)	1	1														
1156 Edgar	Existing Sidewalk	1	1														
1160 Edgar	Flat Rockscape, remove concrete panel & small block wall	1	1				1						1				
1168 Edgar	Flat, Remove boxwood hedge row	1	1			1							1				
1172 Edgar	Flat Grass, remove concrete panel	1	1			1											
1190 Edgar	Flat grass,				1	1							1				
12th & Edgar Curb Ramp (S)	Complete new ramp								1							1	
12th & Edgar Curb Ramp (N)	Complete new ramp, remove large tree			1						1							

EUCLID AVE - WEST SIDE 8th to 12th Street

Address	Description	Remove Exist. Driveway Approach	New Driveway Approach	Remove Large Tree	Remove Small Tree	Relocate Mail Box	Adjust Meter Box Elev.	Curb Inlet Catch Basin	Curb Ramp Type A	Curb Ramp Type B	Curb Ramp Type C	Detectable Warning	Go behind SCE Pole	Relocate Candle stick	New Curb & Gutter (LF)	Relocate Hydrant / Blow-off	Relocate Air-Vac
8th & Euclid Curb Ramp (S)	Existing Ramp is good																
8th & Euclid Curb Ramp (N)	Existing Ramp is good																
256 E 8th Ave	Sidewalk Existing		1														
825 Euclid	Flat Dirt, transition sidewalk	1	1														
835 Euclid	flat grass, remove minor landscape shrubs, concrete, and blocks	1	1														
849 Euclid	flat grass	1	1														
861 Euclid	remove bark & pavers, raised dirt around tree		1	1		1											
889 Euclid	some sloped dirt (6" cuts), 2 trees		1	1	1	1											
9th & Euclid Curb Ramp (S)	Complete new ramp, new curb & gutter								1				1	1	50		
9th & Euclid Curb Ramp (N)	New ramp, remove asphalt								1								
901 Euclid	Baptist Church, remove asphalt	2	2														
937 Euclid	Flat Grass, remove section of chainlink fence	1	1														
949 Euclid	Flat grass, remove concrete panel, relocate existing fence					1											
961 Euclid	Existing sidewalk	1	1			1	1										
973 Euclid	Existing Sidewalk	1	1														
985 Euclid	flat dirt, relocate fence	1	1			1											
10th & Euclid Curb Ramp (S)	new curb ramp, relocate chainlink fence									1							
10th & Euclid Curb Ramp (N)	Existing Ramp, add DW Surface											1					
1001 Euclid	Remove Existing Sidewalk (85 ft)																
1015 Euclid	remove & replace concrete landscape wall	1	1														
1025 Euclid	sloped grass (1ft cuts)remove shrub bushes & decorative rocks	1	1														
1037 Euclid	sloped grass (1-2ft cuts)	1	1			1											
1049 Euclid	sloped grass (1-2ft cuts)	1	1			1											
1061 Euclid	Remove bushes, Remove existing sidewalk (50 ft), transition sidewalk	1	1										1				
1075 Euclid	sloped dirt (1ft cuts), remove tree & hedge	1	1	1													
275 E 11th St	sloped grass (1ft cuts), remove hedges												1				
11th & Euclid Curb Ramp (S)	new ramp, remove thick bushes, shrubs, decorative trees, palm tree				4				1								
11th & Euclid Curb Ramp (N)	New curb ramp									1							
296 E 11th St	No work, ROW @ curb																
1129 Euclid	No work, ROW @ curb																
1133 Euclid	No work, ROW @ curb																
1145 Euclid	No work, ROW @ curb																
1149 Euclid	No work, ROW @ curb																
1151 Euclid	flat dirt & grass, remove rose bush	1	1			1											
1155 Euclid	Remove Existing Sidewalk (60 ft), Relocate Concrete Planter Boxes	1	1														
1163 Euclid	Relocate picket fence, relocate crape myrtle tree	1	1			1											
1169 Euclid	Remove Existing Sidewalk (60 ft)	1	1			1											
1175 Euclid	Flat Dirt	1	1			1											
1181 Euclid	Existing Sidewalk	1	1			1											
287 E 12th St	Empty Lot, flat dirt																
12th & Euclid Curb Ramp (S)	Remove large tree, work around SCE equipment				1								1	1		1	
12th & Euclid Curb Ramp (N)	New Ramp									1							

EUCLID AVE - EAST SIDE 8th to 12th Street

Address	Description	Remove Exist. Driveway Approach	New Driveway Approach	Remove Large Tree	Remove Small Tree	Relocate Mail Box	Adjust Meter Box Elev.	Curb Inlet Catch Basin	Curb Ramp Type A	Curb Ramp Type B	Curb Ramp Type C	Detectable Warning	Go behind SCE Pole	Relocate Candle stick light Pole	New Curb & Gutter (LF)	Relocate Hydrant / Blow-off	Relocate Air-Vac
8th & Euclid Curb Ramp (S)	Existing Ramp is good																
8th & Euclid Curb Ramp (N)	Existing Ramp is good																
802 Euclid	empty lot, flat dirt, remove Large tree stump																
826 Euclid	sloped grass (6" cuts), remove trees	1	1	1	1												
848 Euclid	flat grass	2	2			1	1										
850 Euclid	sloped grass (6" cuts)	1	1				1										
870 Euclid	Sidewalk Existing	1	1				1										
880 Euclid	remove decorative rocks, asphalt driveway	1	1			1	1										
886 Euclid	empty lot, sloped dirt (6" cuts)					1	1										
9th & Euclid Curb Ramp (S)	New Curb Ramp								1								
9th & Euclid Curb Ramp (N)	New Curb Ramp								1								
904 Euclid	flat dirt, remove large tree	1	1	1													
914 Euclid	Flat Grass, remove landscape bricks	1	1				1										
926 Euclid	Flat Grass, remove paver section						1										
938 Euclid	Flat Grass, Existing Sidewalk	1	1				1										
946 Euclid	Remove pavers, shrubs, bushes					1	1										
962 euclid	Flat Dirt, remove large tree	1	1	1			1										
986 Euclid	flat grass & dirt	1	1			1	1										
10th & Euclid Curb Ramp (S)	New Ramp										2			1			
10th & Euclid Curb Ramp (N)	Existing Ramp is good																
1002 Euclid	Existing Sidewalk	1	1														
1014 Euclid	raised grass, remove pavers, relocate existing brick boarder wall	1	1														
1026 Euclid	sloped grass (6" cuts), remove concrete panel	1	1														
1028 Euclid	remove boxwood headge row	1	1				1										
1050 Euclid	remove pavers, decorative bricks, rose bush, and shrubs. Relocate Block Wall & Pillars	1	1														
1062 Euclid	Remove Existing Sidewalk (40 ft)	1	1														
1074 Euclid	sloped grass (1 ft cuts)	1	1				1										
1086 Euclid	sloped dirt (6" - 1ft cuts), remove rocks & cactus	1	1														
11th & Euclid Curb Ramp (S)	New Ramp, remove raised dirt and rock									1							
11th & Euclid Curb Ramp (N)	New ramp, relocate chainlink fence, work around SCE pole & cabinet										2		1	1			
310 E 11th St	No Work, ROW at Curb																
1130 Euclid	Empty Lot, sloped dirt (6" - 1ft cuts)																
1134 Euclid	Empty Lot, sloped dirt (6" - 1ft cuts)																
1138 Euclid	sloped grass (1-2ft cuts), remove concrete panel	1	1			1											
1140 Euclid	Flat Dirt	1	1				1										
1146 Euclid	Existing Sidewalk	1	1														
1148 Euclid	Existing Sidewalk	1	1														
1154 Euclid	Empty Lot, sloped dirt (6" - 1ft cuts)																
1164 Euclid	Existing Sidewalk	1	1				1										
1170 Euclid	Existing Sidewalk	1	1	1		1											
1176 Euclid	Remove Existing Sidewalk (50 ft), relocate block wall and pillars	1	1			1											
1182 Euclid	Existing Sidewalk	1	1				1										
1188 Euclid	flat rockscape, transition sidewalk	1	1				1										
301 E 12th St	flat grass		1												30		
12th & Euclid Curb Ramp (S)	new ramp									1							
12th & Euclid Curb Ramp (N)	new ramp									1							

"General Decision Number: CA20240025 01/19/2024

Superseded General Decision Number: CA20230025

State: California

Construction Types: Building, Heavy (Heavy and Dredging) and Highway

County: Riverside County in California.

BUILDING CONSTRUCTION PROJECTS; DREDGING PROJECTS (does not include hopper dredge work); HEAVY CONSTRUCTION PROJECTS (does not include water well drilling); HIGHWAY CONSTRUCTION PROJECTS

Note: Contracts subject to the Davis-Bacon Act are generally required to pay at least the applicable minimum wage rate required under Executive Order 14026 or Executive Order 13658. Please note that these Executive Orders apply to covered contracts entered into by the federal government that are subject to the Davis-Bacon Act itself, but do not apply to contracts subject only to the Davis-Bacon Related Acts, including those set forth at 29 CFR 5.1(a)(1).

If the contract is entered into on or after January 30, 2022, or the contract is renewed or extended (e.g., an option is exercised) on or after January 30, 2022: Executive Order 14026 generally applies to the contract. The contractor must pay all covered workers at least \$17.20 per hour (or the applicable wage rate listed on this wage determination, if it is higher) for all hours spent performing on the contract in 2024.

If the contract was awarded on or between January 1, 2015 and January 29, 2022, and the contract is not renewed or extended on or after January 30, 2022: Executive Order 13658 generally applies to the contract. The contractor must pay all covered workers at least \$12.90 per hour (or the applicable wage rate listed on this wage determination, if it is higher) for all hours spent performing on that contract in 2024.

The applicable Executive Order minimum wage rate will be

adjusted annually. If this contract is covered by one of the Executive Orders and a classification considered necessary for performance of work on the contract does not appear on this wage determination, the contractor must still submit a conformance request.

Additional information on contractor requirements and worker protections under the Executive Orders is available at <http://www.dol.gov/whd/govcontracts>.

Modification Number	Publication Date
0	01/05/2024
1	01/12/2024
2	01/19/2024

ASBE0005-002 09/01/2023

	Rates	Fringes
Asbestos Workers/Insulator (Includes the application of all insulating materials, protective coverings, coatings, and finishes to all types of mechanical systems).....	\$ 49.58	25.27
Fire Stop Technician (Application of Firestopping Materials for wall openings and penetrations in walls, floors, ceilings and curtain walls).....	\$ 36.97	20.36

ASBE0005-004 07/04/2022

	Rates	Fringes
Asbestos Removal worker/hazardous material handler (Includes preparation, wetting, stripping, removal, scrapping, vacuuming, bagging and disposing of all insulation materials from mechanical systems, whether they contain asbestos or not)....	\$ 23.52	13.37

BOIL0092-003 01/01/2024

	Rates	Fringes
BOILERMAKER.....	\$ 51.98	42.11

* BRCA0004-011 05/01/2020

	Rates	Fringes
BRICKLAYER; MARBLE SETTER.....	\$ 41.48	18.63

*The wage scale for prevailing wage projects performed in Blythe, China lake, Death Valley, Fort Irwin, Twenty-Nine Palms, Needles and 1-15 corridor (Barstow to the Nevada State Line) will be Three Dollars (\$3.00) above the standard San Bernardino/Riverside County hourly wage rate

BRCA0018-004 06/01/2022

	Rates	Fringes
MARBLE FINISHER.....	\$ 37.87	14.13
TILE FINISHER.....	\$ 32.44	12.54
TILE LAYER.....	\$ 45.05	18.33

BRCA0018-010 09/01/2022

	Rates	Fringes
TERRAZZO FINISHER.....	\$ 38.37	14.13
TERRAZZO WORKER/SETTER.....	\$ 46.49	14.66

CARP0213-001 07/01/2021

	Rates	Fringes
CARPENTER		
(1) Carpenter, Cabinet Installer, Insulation Installer, Hardwood Floor Worker and acoustical installer.....	\$ 51.60	16.28
(2) Millwright.....	\$ 52.10	16.48
(3) Piledrivermen/Derrick Bargeman, Bridge or Dock Carpenter, Heavy Framer, Rock Bargeman or Scowman, Rockslinger, Shingler (Commercial).....	\$ 51.73	16.28
(4) Pneumatic Nailer, Power Stapler.....	\$ 51.85	16.28
(5) Sawfiler.....	\$ 51.69	16.28
(6) Scaffold Builder.....	\$ 42.80	16.28
(7) Table Power Saw Operator.....	\$ 51.70	16.28

FOOTNOTE: Work of forming in the construction of open cut sewers or storm drains, on operations in which horizontal

lagging is used in conjunction with steel H-Beams driven or placed in pre- drilled holes, for that portion of a lagged trench against which concrete is poured, namely, as a substitute for back forms (which work is performed by piledrivers): \$0.13 per hour additional.

 CARP0213-002 07/01/2021

Rates Fringes

Diver

(1) Wet.....	\$ 834.40	16.28
(2) Standby.....	\$ 445.84	16.28
(3) Tender.....	\$ 437.84	16.28
(4) Assistant Tender.....	\$ 413.84	16.28

Amounts in ""Rates' column are per day

 CARP0213-004 07/01/2021

Rates Fringes

Drywall

DRYWALL INSTALLER/LATHER....	\$ 51.60	16.28
STOCKER/SCRAPPER.....	\$ 22.16	8.62

 CARP0721-001 07/01/2021

Rates Fringes

Modular Furniture Installer.....	\$ 21.85	7.15
----------------------------------	----------	------

 * ELEC0440-001 01/01/2024

Rates Fringes

ELECTRICIAN

INSIDE ELECTRICIAN.....	\$ 53.76	3%+27.50
INTELLIGENT TRANSPORTATION SYSTEMS		
Electrician.....	\$ 36.99	3%+23.18
Technician.....	\$ 27.75	3%+23.18

ZONE PAY: Zone A: Free travel zone for all contractors performing work in Zone A.
 Zone B: Any work performed in Zone (B) shall add \$12.00 per hour to the current wage scale. Zone (B) shall be the area from the eastern perimeter of Zone (A) to a line which runs north and south beginning at Little Morongo Canyon (San Bernardino/Riverside County Line), Southeast along the Coachella Tunnels, Colorado River Aqueduct and Mecca Tunnels to Pinkham Wash then South to Box Canyon Road, then southwest along Box Canyon Road to Highway 195 west onto

195 south to Highway 86 to Riverside/Imperial County Line.

ELEC1245-001 06/01/2022

Rates Fringes

LINE CONSTRUCTION

(1) Lineman; Cable splicer..	\$ 64.40	22.58
(2) Equipment specialist (operates crawler tractors, commercial motor vehicles, backhoes, trenchers, cranes (50 tons and below), overhead & underground distribution line equipment).....	\$ 50.00	21.30
(3) Groundman.....	\$ 38.23	20.89
(4) Powderman.....	\$ 51.87	18.79

HOLIDAYS: New Year's Day, M.L. King Day, Memorial Day,
Independence Day, Labor Day, Veterans Day, Thanksgiving Day
and day after Thanksgiving, Christmas Day

ELEV0018-001 01/01/2023

Rates Fringes

ELEVATOR MECHANIC.....\$ 63.95 37.335+a+b

FOOTNOTE:

a. PAID VACATION: Employer contributes 8% of regular hourly
rate as vacation pay credit for employees with more than 5
years of service, and 6% for 6 months to 5 years of service.

b. PAID HOLIDAYS: New Year's Day, Memorial Day, Independence
Day, Labor Day, Veterans' Day, Thanksgiving Day, Friday
after Thanksgiving, and Christmas Day.

ENGI0012-003 07/01/2022

Rates Fringes

OPERATOR: Power Equipment
(All Other Work)

GROUP 1.....	\$ 51.90	30.70
GROUP 2.....	\$ 52.68	30.70
GROUP 3.....	\$ 52.97	30.70
GROUP 4.....	\$ 54.46	30.70
GROUP 5.....	\$ 48.96	25.25
GROUP 6.....	\$ 54.68	30.70
GROUP 8.....	\$ 54.79	30.70

GROUP 9.....	\$ 49.29	25.25
GROUP 10.....	\$ 54.91	30.70
GROUP 11.....	\$ 49.41	25.25
GROUP 12.....	\$ 55.08	30.70
GROUP 13.....	\$ 55.18	30.70
GROUP 14.....	\$ 55.21	30.70
GROUP 15.....	\$ 55.29	30.70
GROUP 16.....	\$ 55.41	30.70
GROUP 17.....	\$ 55.58	30.70
GROUP 18.....	\$ 55.68	30.70
GROUP 19.....	\$ 55.79	30.70
GROUP 20.....	\$ 55.91	30.70
GROUP 21.....	\$ 56.08	30.70
GROUP 22.....	\$ 56.18	30.70
GROUP 23.....	\$ 56.29	30.70
GROUP 24.....	\$ 56.41	30.70
GROUP 25.....	\$ 56.58	30.70

OPERATOR: Power Equipment
(Cranes, Piledriving &
Hoisting)

GROUP 1.....	\$ 53.25	30.70
GROUP 2.....	\$ 54.03	30.70
GROUP 3.....	\$ 54.32	30.70
GROUP 4.....	\$ 54.46	30.70
GROUP 5.....	\$ 54.68	30.70
GROUP 6.....	\$ 54.79	30.70
GROUP 7.....	\$ 54.91	30.70
GROUP 8.....	\$ 55.08	30.70
GROUP 9.....	\$ 55.25	30.70
GROUP 10.....	\$ 56.25	30.70
GROUP 11.....	\$ 57.25	30.70
GROUP 12.....	\$ 58.25	30.70
GROUP 13.....	\$ 59.25	30.70

OPERATOR: Power Equipment
(Tunnel Work)

GROUP 1.....	\$ 54.53	30.70
GROUP 2.....	\$ 54.82	30.70
GROUP 3.....	\$ 54.96	30.70
GROUP 4.....	\$ 55.18	30.70
GROUP 5.....	\$ 55.29	30.70
GROUP 6.....	\$ 55.41	30.70
GROUP 7.....	\$ 55.71	30.70

PREMIUM PAY:

\$3.75 per hour shall be paid on all Power Equipment Operator work on the following Military Bases: China Lake Naval Reserve, Vandenberg AFB, Point Arguello, Seely Naval Base, Fort Irwin, Nebo Annex Marine Base, Marine Corp Logistics Base Yermo, Edwards AFB, 29 Palms Marine Base and Camp Pendleton

Workers required to suit up and work in a hazardous material environment: \$2.00 per hour additional. Combination mixer and compressor operator on gunite work shall be classified

as a concrete mobile mixer operator.

SEE ZONE DEFINITIONS AFTER CLASSIFICATIONS

POWER EQUIPMENT OPERATORS CLASSIFICATIONS

GROUP 1: Bargeman; Brakeman; Compressor operator; Ditch Witch, with seat or similar type equipment; Elevator operator-inside; Engineer Oiler; Forklift operator (includes loed, lull or similar types under 5 tons; Generator operator; Generator, pump or compressor plant operator; Pump operator; Signalman; Switchman

GROUP 2: Asphalt-rubber plant operator (nurse tank operator); Concrete mixer operator-skip type; Conveyor operator; Fireman; Forklift operator (includes loed, lull or similar types over 5 tons; Hydrostatic pump operator; oiler crusher (asphalt or concrete plant); Petromat laydown machine; PJU side dum jack; Screening and conveyor machine operator (or similar types); Skiploader (wheel type up to 3/4 yd. without attachment); Tar pot fireman; Temporary heating plant operator; Trenching machine oiler

GROUP 3: Asphalt-rubber blend operator; Bobcat or similar type (Skid steer); Equipment greaser (rack); Ford Ferguson (with dragtype attachments); Helicopter radioman (ground); Stationary pipe wrapping and cleaning machine operator

GROUP 4: Asphalt plant fireman; Backhoe operator (mini-max or similar type); Boring machine operator; Boxman or mixerman (asphalt or concrete); Chip spreading machine operator; Concrete cleaning decontamination machine operator; Concrete Pump Operator (small portable); Drilling machine operator, small auger types (Texoma super economatic or similar types - Hughes 100 or 200 or similar types - drilling depth of 30' maximum); Equipment greaser (grease truck); Guard rail post driver operator; Highline cableway signalman; Hydra-hammer-aero stomper; Micro Tunneling (above ground tunnel); Power concrete curing machine operator; Power concrete saw operator; Power-driven jumbo form setter operator; Power sweeper operator; Rock Wheel Saw/Trencher; Roller operator (compacting); Screed operator (asphalt or concrete); Trenching machine operator (up to 6 ft.); Vacuum or much truck

GROUP 5: Equipment Greaser (Grease Truck/Multi Shift).

GROUP 6: Articulating material hauler; Asphalt plant engineer; Batch plant operator; Bit sharpener; Concrete joint machine operator (canal and similar type); Concrete planer operator; Dandy digger; Deck engine operator; Derrickman (oilfield type); Drilling machine operator, bucket or auger types (Calweld 100 bucket or similar types - Watson 1000 auger or similar types - Texoma 330, 500 or

600 auger or similar types - drilling depth of 45' maximum); Drilling machine operator; Hydrographic seeder machine operator (straw, pulp or seed), Jackson track maintainer, or similar type; Kalamazoo Switch tamper, or similar type; Machine tool operator; Maginnis internal full slab vibrator, Mechanical berm, curb or gutter (concrete or asphalt); Mechanical finisher operator (concrete, Clary-Johnson-Bidwell or similar); Micro tunnel system (below ground); Pavement breaker operator (truck mounted); Road oil mixing machine operator; Roller operator (asphalt or finish), rubber-tired earth moving equipment (single engine, up to and including 25 yds. struck); Self-propelled tar pipelining machine operator; Skiploader operator (crawler and wheel type, over 3/4 yd. and up to and including 1-1/2 yds.); Slip form pump operator (power driven hydraulic lifting device for concrete forms); Tractor operator-bulldozer, tamper-scraper (single engine, up to 100 h.p. flywheel and similar types, up to and including D-5 and similar types); Tugger hoist operator (1 drum); Ultra high pressure waterjet cutting tool system operator; Vacuum blasting machine operator

GROUP 8: Asphalt or concrete spreading operator (tamping or finishing); Asphalt paving machine operator (Barber Greene or similar type); Asphalt-rubber distribution operator; Backhoe operator (up to and including 3/4 yd.), small ford, Case or similar; Cast-in-place pipe laying machine operator; Combination mixer and compressor operator (gunite work); Compactor operator (self-propelled); Concrete mixer operator (paving); Crushing plant operator; Drill Doctor; Drilling machine operator, Bucket or auger types (Calweld 150 bucket or similar types - Watson 1500, 2000 2500 auger or similar types - Texoma 700, 800 auger or similar types - drilling depth of 60' maximum); Elevating grader operator; Grade checker; Gradall operator; Grouting machine operator; Heavy-duty repairman; Heavy equipment robotics operator; Kalamazoo balliste regulator or similar type; Kolman belt loader and similar type; Le Tourneau blob compactor or similar type; Loader operator (Athey, Euclid, Sierra and similar types); Mobark Chipper or similar; Ozzie padder or similar types; P.C. slot saw; Pneumatic concrete placing machine operator (Hackley-Presswell or similar type); Pumpercrete gun operator; Rock Drill or similar types; Rotary drill operator (excluding caisson type); Rubber-tired earth-moving equipment operator (single engine, caterpillar, Euclid, Athey Wagon and similar types with any and all attachments over 25 yds. up to and including 50 cu. yds. struck); Rubber-tired earth-moving equipment operator (multiple engine up to and including 25 yds. struck); Rubber-tired scraper operator (self-loading paddle wheel type-John Deere, 1040 and similar single unit); Self-propelled curb and gutter machine operator; Shuttle buggy; Skiploader operator (crawler and wheel type over 1-1/2 yds. up to and including 6-1/2 yds.); Soil remediation plant

operator; Surface heaters and planer operator; Tractor compressor drill combination operator; Tractor operator (any type larger than D-5 - 100 flywheel h.p. and over, or similar-bulldozer, tamper, scraper and push tractor single engine); Tractor operator (boom attachments), Traveling pipe wrapping, cleaning and bending machine operator; Trenching machine operator (over 6 ft. depth capacity, manufacturer's rating); trenching Machine with Road Miner attachment (over 6 ft depth capacity): Ultra high pressure waterjet cutting tool system mechanic; Water pull (compaction) operator

GROUP 9: Heavy Duty Repairman

GROUP 10: Drilling machine operator, Bucket or auger types (Calweld 200 B bucket or similar types-Watson 3000 or 5000 auger or similar types-Texoma 900 auger or similar types-drilling depth of 105' maximum); Dual drum mixer, dynamic compactor LDC350 (or similar types); Monorail locomotive operator (diesel, gas or electric); Motor patrol-blade operator (single engine); Multiple engine tractor operator (Euclid and similar type-except Quad 9 cat.); Rubber-tired earth-moving equipment operator (single engine, over 50 yds. struck); Pneumatic pipe ramming tool and similar types; Prestressed wrapping machine operator; Rubber-tired earth-moving equipment operator (single engine, over 50 yds. struck); Rubber tired earth moving equipment operator (multiple engine, Euclid, caterpillar and similar over 25 yds. and up to 50 yds. struck), Tower crane repairman; Tractor loader operator (crawler and wheel type over 6-1/2 yds.); Woods mixer operator (and similar Pugmill equipment)

GROUP 11: Heavy Duty Repairman - Welder Combination, Welder - Certified.

GROUP 12: Auto grader operator; Automatic slip form operator; Drilling machine operator, bucket or auger types (Calweld, auger 200 CA or similar types - Watson, auger 6000 or similar types - Hughes Super Duty, auger 200 or similar types - drilling depth of 175' maximum); Hoe ram or similar with compressor; Mass excavator operator less than 750 cu. yards; Mechanical finishing machine operator; Mobile form traveler operator; Motor patrol operator (multi-engine); Pipe mobile machine operator; Rubber-tired earth-moving equipment operator (multiple engine, Euclid, Caterpillar and similar type, over 50 cu. yds. struck); Rubber-tired self-loading scraper operator (paddle-wheel-auger type self-loading - two (2) or more units)

GROUP 13: Rubber-tired earth-moving equipment operator operating equipment with push-pull system (single engine, up to and including 25 yds. struck)

GROUP 14: Canal liner operator; Canal trimmer operator; Remote- control earth-moving equipment operator (operating a second piece of equipment: \$1.00 per hour additional); Wheel excavator operator (over 750 cu. yds.)

GROUP 15: Rubber-tired earth-moving equipment operator, operating equipment with push-pull system (single engine, Caterpillar, Euclid, Athey Wagon and similar types with any and all attachments over 25 yds. and up to and including 50 yds. struck); Rubber-tired earth-moving equipment operator, operating equipment with push-pull system (multiple engine-up to and including 25 yds. struck)

GROUP 16: Rubber-tired earth-moving equipment operator, operating equipment with push-pull system (single engine, over 50 yds. struck); Rubber-tired earth-moving equipment operator, operating equipment with push-pull system (multiple engine, Euclid, Caterpillar and similar, over 25 yds. and up to 50 yds. struck)

GROUP 17: Rubber-tired earth-moving equipment operator, operating equipment with push-pull system (multiple engine, Euclid, Caterpillar and similar, over 50 cu. yds. struck); Tandem tractor operator (operating crawler type tractors in tandem - Quad 9 and similar type)

GROUP 18: Rubber-tired earth-moving equipment operator, operating in tandem (scrapers, belly dumps and similar types in any combination, excluding compaction units - single engine, up to and including 25 yds. struck)

GROUP 19: Rotex concrete belt operator (or similar types); Rubber-tired earth-moving equipment operator, operating in tandem (scrapers, belly dumps and similar types in any combination, excluding compaction units - single engine, Caterpillar, Euclid, Athey Wagon and similar types with any and all attachments over 25 yds. and up to and including 50 cu. yds. struck); Rubber-tired earth-moving equipment operator, operating in tandem (scrapers, belly dumps and similar types in any combination, excluding compaction units - multiple engine, up to and including 25 yds. struck)

GROUP 20: Rubber-tired earth-moving equipment operator, operating in tandem (scrapers, belly dumps and similar types in any combination, excluding compaction units - single engine, over 50 yds. struck); Rubber-tired earth-moving equipment operator, operating in tandem (scrapers, belly dumps, and similar types in any combination, excluding compaction units - multiple engine, Euclid, Caterpillar and similar, over 25 yds. and up to 50 yds. struck)

GROUP 21: Rubber-tired earth-moving equipment operator, operating in tandem (scrapers, belly dumps and similar

types in any combination, excluding compaction units - multiple engine, Euclid, Caterpillar and similar type, over 50 cu. yds. struck)

GROUP 22: Rubber-tired earth-moving equipment operator, operating equipment with the tandem push-pull system (single engine, up to and including 25 yds. struck)

GROUP 23: Rubber-tired earth-moving equipment operator, operating equipment with the tandem push-pull system (single engine, Caterpillar, Euclid, Athey Wagon and similar types with any and all attachments over 25 yds. and up to and including 50 yds. struck); Rubber-tired earth-moving equipment operator, operating with the tandem push-pull system (multiple engine, up to and including 25 yds. struck)

GROUP 24: Rubber-tired earth-moving equipment operator, operating equipment with the tandem push-pull system (single engine, over 50 yds. struck); Rubber-tired earth-moving equipment operator, operating equipment with the tandem push-pull system (multiple engine, Euclid, Caterpillar and similar, over 25 yds. and up to 50 yds. struck)

GROUP 25: Concrete pump operator-truck mounted; Rubber-tired earth-moving equipment operator, operating equipment with the tandem push-pull system (multiple engine, Euclid, Caterpillar and similar type, over 50 cu. yds. struck)

CRANES, PILEDIVING AND HOISTING EQUIPMENT CLASSIFICATIONS

GROUP 1: Engineer oiler; Fork lift operator (includes loed, lull or similar types)

GROUP 2: Truck crane oiler

GROUP 3: A-frame or winch truck operator; Ross carrier operator (jobsite)

GROUP 4: Bridge-type unloader and turntable operator; Helicopter hoist operator

GROUP 5: Hydraulic boom truck; Stinger crane (Austin-Western or similar type); Tugger hoist operator (1 drum)

GROUP 6: Bridge crane operator; Cretor crane operator; Hoist operator (Chicago boom and similar type); Lift mobile operator; Lift slab machine operator (Vagtborg and similar types); Material hoist and/or manlift operator; Polar gantry crane operator; Self Climbing scaffold (or similar type); Shovel, backhoe, dragline, clamshell operator (over 3/4 yd. and up to 5 cu. yds. mrc); Tugger hoist operator

GROUP 7: Pedestal crane operator; Shovel, backhoe, dragline, clamshell operator (over 5 cu. yds. mrc); Tower crane repair; Tugger hoist operator (3 drum)

GROUP 8: Crane operator (up to and including 25 ton capacity); Crawler transporter operator; Derrick barge operator (up to and including 25 ton capacity); Hoist operator, stiff legs, Guy derrick or similar type (up to and including 25 ton capacity); Shovel, backhoe, dragline, clamshell operator (over 7 cu. yds., M.R.C.)

GROUP 9: Crane operator (over 25 tons and up to and including 50 tons mrc); Derrick barge operator (over 25 tons up to and including 50 tons mrc); Highline cableway operator; Hoist operator, stiff legs, Guy derrick or similar type (over 25 tons up to and including 50 tons mrc); K-crane operator; Polar crane operator; Self erecting tower crane operator maximum lifting capacity ten tons

GROUP 10: Crane operator (over 50 tons and up to and including 100 tons mrc); Derrick barge operator (over 50 tons up to and including 100 tons mrc); Hoist operator, stiff legs, Guy derrick or similar type (over 50 tons up to and including 100 tons mrc), Mobile tower crane operator (over 50 tons, up to and including 100 tons M.R.C.); Tower crane operator and tower gantry

GROUP 11: Crane operator (over 100 tons and up to and including 200 tons mrc); Derrick barge operator (over 100 tons up to and including 200 tons mrc); Hoist operator, stiff legs, Guy derrick or similar type (over 100 tons up to and including 200 tons mrc); Mobile tower crane operator (over 100 tons up to and including 200 tons mrc)

GROUP 12: Crane operator (over 200 tons up to and including 300 tons mrc); Derrick barge operator (over 200 tons up to and including 300 tons mrc); Hoist operator, stiff legs, Guy derrick or similar type (over 200 tons, up to and including 300 tons mrc); Mobile tower crane operator (over 200 tons, up to and including 300 tons mrc)

GROUP 13: Crane operator (over 300 tons); Derrick barge operator (over 300 tons); Helicopter pilot; Hoist operator, stiff legs, Guy derrick or similar type (over 300 tons); Mobile tower crane operator (over 300 tons)

TUNNEL CLASSIFICATIONS

GROUP 1: Skiploader (wheel type up to 3/4 yd. without attachment)

GROUP 2: Power-driven jumbo form setter operator

GROUP 3: Dinkey locomotive or motorperson (up to and

including 10 tons)

GROUP 4: Bit sharpener; Equipment greaser (grease truck); Slip form pump operator (power-driven hydraulic lifting device for concrete forms); Tugger hoist operator (1 drum); Tunnel locomotive operator (over 10 and up to and including 30 tons)

GROUP 5: Backhoe operator (up to and including 3/4 yd.); Small Ford, Case or similar; Drill doctor; Grouting machine operator; Heading shield operator; Heavy-duty repairperson; Loader operator (Athey, Euclid, Sierra and similar types); Mucking machine operator (1/4 yd., rubber-tired, rail or track type); Pneumatic concrete placing machine operator (Hackley-Presswell or similar type); Pneumatic heading shield (tunnel); Pumpcrete gun operator; Tractor compressor drill combination operator; Tugger hoist operator (2 drum); Tunnel locomotive operator (over 30 tons)

GROUP 6: Heavy Duty Repairman

GROUP 7: Tunnel mole boring machine operator

ENGINEERS ZONES

\$1.00 additional per hour for all of IMPERIAL County and the portions of KERN, RIVERSIDE & SAN BERNARDINO Counties as defined below:

That area within the following Boundary: Begin in San Bernardino County, approximately 3 miles NE of the intersection of I-15 and the California State line at that point which is the NW corner of Section 1, T17N,m R14E, San Bernardino Meridian. Continue W in a straight line to that point which is the SW corner of the northwest quarter of Section 6, T27S, R42E, Mt. Diablo Meridian. Continue North to the intersection with the Inyo County Boundary at that point which is the NE corner of the western half of the northern quarter of Section 6, T25S, R42E, MDM. Continue W along the Inyo and San Bernardino County boundary until the intersection with Kern County, as that point which is the SE corner of Section 34, T24S, R40E, MDM. Continue W along the Inyo and Kern County boundary until the intersection with Tulare County, at that point which is the SW corner of the SE quarter of Section 32, T24S, R37E, MDM. Continue W along the Kern and Tulare County boundary, until that point which is the NW corner of T25S, R32E, MDM. Continue S following R32E lines to the NW corner of T31S, R32E, MDM. Continue W to the NW corner of T31S, R31E, MDM. Continue S to the SW corner of T32S, R31E, MDM. Continue W to SW corner of SE quarter of Section 34, T32S, R30E, MDM. Continue S to SW corner of T11N, R17W, SBM. Continue E along south boundary of T11N, SBM to SW corner of T11N, R7W, SBM. Continue S to SW corner of T9N, R7W, SBM. Continue E along south boundary of T9N, SBM to SW corner of T9N, R1E, SBM.

Continue S along west boundary of R1E, SMB to Riverside County line at the SW corner of T1S, R1E, SBM. Continue E along south boundary of T1s, SBM (Riverside County Line) to SW corner of T1S, R10E, SBM. Continue S along west boundary of R10E, SBM to Imperial County line at the SW corner of T8S, R10E, SBM. Continue W along Imperial and Riverside county line to NW corner of T9S, R9E, SBM. Continue S along the boundary between Imperial and San Diego Counties, along the west edge of R9E, SBM to the south boundary of Imperial County/California state line. Follow the California state line west to Arizona state line, then north to Nevada state line, then continuing NW back to start at the point which is the NW corner of Section 1, T17N, R14E, SBM

\$1.00 additional per hour for portions of SAN LUIS OBISPO, KERN, SANTA BARBARA & VENTURA as defined below:

That area within the following Boundary: Begin approximately 5 miles north of the community of Cholame, on the Monterey County and San Luis Obispo County boundary at the NW corner of T25S, R16E, Mt. Diablo Meridian. Continue south along the west side of R16E to the SW corner of T30S, R16E, MDM. Continue E to SW corner of T30S, R17E, MDM. Continue S to SW corner of T31S, R17E, MDM. Continue E to SW corner of T31S, R18E, MDM. Continue S along West side of R18E, MDM as it crosses into San Bernardino Meridian numbering area and becomes R30W. Follow the west side of R30W, SBM to the SW corner of T9N, R30W, SBM. Continue E along the south edge of T9N, SBM to the Santa Barbara County and Ventura County boundary at that point which is the SW corner of Section 34. T9N, R24W, SBM, continue S along the Ventura County line to that point which is the SW corner of the SE quarter of Section 32, T7N, R24W, SBM. Continue E along the south edge of T7N, SBM to the SE corner to T7N, R21W, SBM. Continue N along East side of R21W, SBM to Ventura County and Kern County boundary at the NE corner of T8N, R21W. Continue W along the Ventura County and Kern County boundary to the SE corner of T9N, R21W. Continue North along the East edge of R21W, SBM to the NE corner of T12N, R21W, SBM. Continue West along the north edge of T12N, SBM to the SE corner of T32S, R21E, MDM. [T12N SBM is a think strip between T11N SBM and T32S MDM]. Continue North along the East side of R21E, MDM to the Kings County and Kern County border at the NE corner of T25S, R21E, MDM, continue West along the Kings County and Kern County Boundary until the intersection of San Luis Obispo County. Continue west along the Kings County and San Luis Obispo County boundary until the intersection with Monterey County. Continue West along the Monterey County and San Luis Obispo County boundary to the beginning point at the NW corner of T25S, R16E, MDM.

\$2.00 additional per hour for INYO and MONO Counties and the Northern portion of SAN BERNARDINO County as defined below:

That area within the following Boundary: Begin at the intersection of the northern boundary of Mono County and the California state line at the point which is the center of Section 17, T10N, R22E, Mt. Diablo Meridian. Continue S then SE along the entire western boundary of Mono County, until it reaches Inyo County at the point which is the NE corner of the Western half of the NW quarter of Section 2, T8S, R29E, MDM. Continue SSE along the entire western boundary of Inyo County, until the intersection with Kern County at the point which is the SW corner of the SE 1/4 of Section 32, T24S, R37E, MDM. Continue E along the Inyo and Kern County boundary until the intersection with San Bernardino County at that point which is the SE corner of section 34, T24S, R40E, MDM. Continue E along the Inyo and San Bernardino County boundary until the point which is the NE corner of the Western half of the NW quarter of Section 6, T25S, R42E, MDM. Continue S to that point which is the SW corner of the NW quarter of Section 6, T27S, R42E, MDM. Continue E in a straight line to the California and Nevada state border at the point which is the NW corner of Section 1, T17N, R14E, San Bernardino Meridian. Then continue NW along the state line to the starting point, which is the center of Section 18, T10N, R22E, MDM.

REMAINING AREA NOT DEFINED ABOVE RECIEVES BASE RATE

 ENGI0012-004 08/01/2023

Rates Fringes

OPERATOR: Power Equipment
 (DREDGING)

(1) Leverman.....	\$ 64.10	34.60
(2) Dredge dozer.....	\$ 58.13	34.60
(3) Deckmate.....	\$ 58.02	34.60
(4) Winch operator (stern winch on dredge).....	\$ 57.47	34.60
(5) Fireman-Oiler, Deckhand, Bargeman, Leveehand.....	\$ 56.93	34.60
(6) Barge Mate.....	\$ 57.54	34.60

 IRON0433-006 01/01/2024

Rates Fringes

IRONWORKER

Fence Erector.....	\$ 42.53	26.26
Ornamental, Reinforcing and Structural.....	\$ 47.45	34.90

PREMIUM PAY:

\$9.00 additional per hour at the following locations:

China Lake Naval Test Station, Chocolate Mountains Naval Reserve-Niland, Edwards AFB, Fort Irwin Military Station, Fort Irwin Training Center-Goldstone, San Clemente Island, San Nicholas Island, Susanville Federal Prison, 29 Palms - Marine Corps, U.S. Marine Base - Barstow, U.S. Naval Air Facility - Sealey, Vandenberg AFB Army Defense Language Institute - Monterey, Fallon Air Base, Naval Post Graduate School - Monterey, Yermo Marine Corps Logistics Center
Port Hueneme, Port Mugu, U.S. Coast Guard Station - Two Rock

LABO0300-005 08/01/2022

	Rates	Fringes
Asbestos Removal Laborer.....	\$ 39.23	23.28

SCOPE OF WORK: Includes site mobilization, initial site cleanup, site preparation, removal of asbestos-containing material and toxic waste, encapsulation, enclosure and disposal of asbestos- containing materials and toxic waste by hand or with equipment or machinery; scaffolding, fabrication of temporary wooden barriers and assembly of decontamination stations.

LABO0345-001 07/01/2022

	Rates	Fringes
LABORER (GUNITE)		
GROUP 1.....	\$ 48.50	21.37
GROUP 2.....	\$ 47.55	21.37
GROUP 3.....	\$ 44.01	21.37

FOOTNOTE: GUNITE PREMIUM PAY: Workers working from a Bosn'n's Chair or suspended from a rope or cable shall receive 40 cents per hour above the foregoing applicable classification rates. Workers doing gunite and/or shotcrete work in a tunnel shall receive 35 cents per hour above the foregoing applicable classification rates, paid on a portal-to-portal basis. Any work performed on, in or above any smoke stack, silo, storage elevator or similar type of structure, when such structure is in excess of 75'-0"" above base level and which work must be performed in whole or in part more than 75'-0"" above base level, that work performed above the 75'-0"" level shall be compensated for at 35 cents per hour above the applicable classification wage rate.

GUNITE LABORER CLASSIFICATIONS

GROUP 1: Rodmen, Nozzlemen

GROUP 2: Gunmen

GROUP 3: Reboundmen

LABO1184-001 07/01/2022

Rates Fringes

Laborers: (HORIZONTAL DIRECTIONAL DRILLING)

(1) Drilling Crew Laborer...	\$ 40.69	18.25
(2) Vehicle Operator/Hauler.	\$ 40.86	18.25
(3) Horizontal Directional Drill Operator.....	\$ 42.71	18.25
(4) Electronic Tracking Locator.....	\$ 44.71	18.25

Laborers: (STRIPING/SLURRY SEAL)

GROUP 1.....	\$ 41.90	21.32
GROUP 2.....	\$ 43.20	21.32
GROUP 3.....	\$ 45.21	21.32
GROUP 4.....	\$ 46.95	21.32

LABORERS - STRIPING CLASSIFICATIONS

GROUP 1: Protective coating, pavement sealing, including repair and filling of cracks by any method on any surface in parking lots, game courts and playgrounds; carstops; operation of all related machinery and equipment; equipment repair technician

GROUP 2: Traffic surface abrasive blaster; pot tender - removal of all traffic lines and markings by any method (sandblasting, waterblasting, grinding, etc.) and preparation of surface for coatings. Traffic control person: controlling and directing traffic through both conventional and moving lane closures; operation of all related machinery and equipment

GROUP 3: Traffic delineating device applicator: Layout and application of pavement markers, delineating signs, rumble and traffic bars, adhesives, guide markers, other traffic delineating devices including traffic control. This category includes all traffic related surface preparation (sandblasting, waterblasting, grinding) as part of the application process. Traffic protective delineating system installer: removes, relocates, installs, permanently affixed roadside and parking delineation barricades, fencing, cable anchor, guard rail, reference signs,

monument markers; operation of all related machinery and equipment; power broom sweeper

GROUP 4: Striper: layout and application of traffic stripes and markings; hot thermo plastic; tape traffic stripes and markings, including traffic control; operation of all related machinery and equipment

LABO1184-002 07/01/2022

Rates Fringes

LABORER (TUNNEL)

GROUP 1.....	\$ 45.68	23.30
GROUP 2.....	\$ 46.00	23.30
GROUP 3.....	\$ 46.46	23.30
GROUP 4.....	\$ 47.15	23.30

LABORER

GROUP 1.....	\$ 36.39	21.04
GROUP 2.....	\$ 36.94	21.04
GROUP 3.....	\$ 37.49	21.04
GROUP 4.....	\$ 39.04	21.04
GROUP 5.....	\$ 39.39	21.04

LABORER CLASSIFICATIONS

GROUP 1: Cleaning and handling of panel forms; Concrete screeding for rough strike-off; Concrete, water curing; Demolition laborer, the cleaning of brick if performed by a worker performing any other phase of demolition work, and the cleaning of lumber; Fire watcher, limber, brush loader, piler and debris handler; Flag person; Gas, oil and/or water pipeline laborer; Laborer, asphalt-rubber material loader; Laborer, general or construction; Laborer, general clean-up; Laborer, landscaping; Laborer, jetting; Laborer, temporary water and air lines; Material hose operator (walls, slabs, floors and decks); Plugging, filling of shee bolt holes; Dry packing of concrete; Railroad maintenance, repair track person and road beds; Streetcar and railroad construction track laborers; Rigging and signaling; Scaler; Slip form raiser; Tar and mortar; Tool crib or tool house laborer; Traffic control by any method; Window cleaner; Wire mesh pulling - all concrete pouring operations

GROUP 2: Asphalt shoveler; Cement dumper (on 1 yd. or larger mixer and handling bulk cement); Cesspool digger and installer; Chucktender; Chute handler, pouring concrete, the handling of the chute from readymix trucks, such as walls, slabs, decks, floors, foundation, footings, curbs, gutters and sidewalks; Concrete curer, impervious membrane and form oiler; Cutting torch operator (demolition); Fine grader, highways and street paving, airport, runways and similar type heavy construction; Gas, oil and/or water

pipeline wrapper - pot tender and form person; Guinea chaser; Headerboard person - asphalt; Laborer, packing rod steel and pans; Membrane vapor barrier installer; Power broom sweeper (small); Riprap stonepaver, placing stone or wet sacked concrete; Roto scraper and tiller; Sandblaster (pot tender); Septic tank digger and installer(lead); Tank scaler and cleaner; Tree climber, faller, chain saw operator, Pittsburgh chipper and similar type brush shredder; Underground laborer, including caisson bellower

GROUP 3: Buggymobile person; Concrete cutting torch; Concrete pile cutter; Driller, jackhammer, 2-1/2 ft. drill steel or longer; Dri-pak-it machine; Gas, oil and/or water pipeline wrapper, 6-in. pipe and over, by any method, inside and out; High scaler (including drilling of same); Hydro seeder and similar type; Impact wrench multi-plate; Kettle person, pot person and workers applying asphalt, lay-kold, creosote, lime caustic and similar type materials ("applying" means applying, dipping, brushing or handling of such materials for pipe wrapping and waterproofing); Operator of pneumatic, gas, electric tools, vibrating machine, pavement breaker, air blasting, come-alongs, and similar mechanical tools not separately classified herein; Pipelayer's backup person, coating, grouting, making of joints, sealing, caulking, diapering and including rubber gasket joints, pointing and any and all other services; Rock slinger; Rotary scarifier or multiple head concrete chipping scarifier; Steel headerboard and guideline setter; Tamper, Barko, Wacker and similar type; Trenching machine, hand-propelled

GROUP 4: Asphalt raker, lute person, ironer, asphalt dump person, and asphalt spreader boxes (all types); Concrete core cutter (walls, floors or ceilings), grinder or sander; Concrete saw person, cutting walls or flat work, scoring old or new concrete; Cribber, shorer, lagging, sheeting and trench bracing, hand-guided lagging hammer; Head rock slinger; Laborer, asphalt- rubber distributor boot person; Laser beam in connection with laborers' work; Oversize concrete vibrator operator, 70 lbs. and over; Pipelayer performing all services in the laying and installation of pipe from the point of receiving pipe in the ditch until completion of operation, including any and all forms of tubular material, whether pipe, metallic or non-metallic, conduit and any other stationary type of tubular device used for the conveying of any substance or element, whether water, sewage, solid gas, air, or other product whatsoever and without regard to the nature of material from which the tubular material is fabricated; No-joint pipe and stripping of same; Prefabricated manhole installer; Sandblaster (nozzle person), water blasting, Porta Shot-Blast

GROUP 5: Blaster powder, all work of loading holes, placing and blasting of all powder and explosives of whatever type,

regardless of method used for such loading and placing;
 Driller: All power drills, excluding jackhammer, whether
 core, diamond, wagon, track, multiple unit, and any and all
 other types of mechanical drills without regard to the form
 of motive power; Toxic waste removal

TUNNEL LABORER CLASSIFICATIONS

GROUP 1: Batch plant laborer; Changehouse person; Dump
 person; Dump person (outside); Swamper (brake person and
 switch person on tunnel work); Tunnel materials handling
 person; Nipper; Pot tender, using mastic or other materials
 (for example, but not by way of limitation, shotcrete, etc.)

GROUP 2: Chucktender, cabledtender; Loading and unloading
 agitator cars; Vibrator person, jack hammer, pneumatic
 tools (except driller); Bull gang mucker, track person;
 Concrete crew, including rodder and spreader

GROUP 3: Blaster, driller, powder person; Chemical grout jet
 person; Cherry picker person; Grout gun person; Grout mixer
 person; Grout pump person; Jackleg miner; Jumbo person;
 Kemper and other pneumatic concrete placer operator; Miner,
 tunnel (hand or machine); Nozzle person; Operating of
 troweling and/or grouting machines; Powder person (primer
 house); Primer person; Sandblaster; Shotcrete person; Steel
 form raiser and setter; Timber person, retimber person,
 wood or steel; Tunnel Concrete finisher

GROUP 4: Diamond driller; Sandblaster; Shaft and raise work

 LABO1184-004 07/01/2022

	Rates	Fringes
Brick Tender.....	\$ 37.32	21.45

 LABO1414-001 08/03/2022

	Rates	Fringes
LABORER		
PLASTER CLEAN-UP LABORER....	\$ 38.92	23.32
PLASTER TENDER.....	\$ 41.47	23.32

Work on a swing stage scaffold: \$1.00 per hour additional.

 PAIN0036-001 07/01/2023

	Rates	Fringes
Painters: (Including Lead Abatement)		

(1) Repaint (excludes San Diego County).....	\$ 29.59	17.12
(2) All Other Work.....	\$ 38.52	18.64

REPAINT of any previously painted structure. Exceptions: work involving the aerospace industry, breweries, commercial recreational facilities, hotels which operate commercial establishments as part of hotel service, and sports facilities.

PAIN0036-008 09/01/2022

	Rates	Fringes
DRYWALL FINISHER/TAPER.....	\$ 46.28	23.52

PAIN0036-015 01/01/2020

	Rates	Fringes
GLAZIER.....	\$ 43.45	23.39

FOOTNOTE: Additional \$1.25 per hour for work in a condor, from the third (3rd) floor and up Additional \$1.25 per hour for work on the outside of the building from a swing stage or any suspended contrivance, from the ground up

PLAS0200-009 08/03/2022

	Rates	Fringes
PLASTERER.....	\$ 47.37	19.64

PLAS0500-002 07/01/2020

	Rates	Fringes
CEMENT MASON/CONCRETE FINISHER...	\$ 38.50	25.91

PLUM0016-001 09/01/2023

	Rates	Fringes
PLUMBER/PIPEFITTER Work ONLY on new additions and remodeling of bars, restaurant, stores and commercial buildings not to exceed 5,000 sq. ft. of floor space.....	\$ 53.51	25.28
Work ONLY on strip malls, light commercial, tenant		

improvement and remodel
work.....\$ 42.49 23.86

All other work except work
on new additions and
remodeling of bars,
restaurant, stores and
commercial buildings not
to exceed 5,000 sq. ft. of
floor space and work on
strip malls, light
commercial, tenant
improvement and remodel
work.....\$ 55.18 26.26

PLUM0345-001 09/01/2023

Rates Fringes

PLUMBER

Landscape/Irrigation Fitter.\$ 40.20 25.90
Sewer & Storm Drain Work....\$ 44.29 23.28

ROOF0036-002 08/13/2023

Rates Fringes

ROOFER.....\$ 46.02 20.05

FOOTNOTE: Pitch premium: Work on which employees are exposed
to pitch fumes or required to handle pitch, pitch base or
pitch impregnated products, or any material containing coal
tar pitch, the entire roofing crew shall receive \$1.75 per
hour ""pitch premium"" pay.

SFCA0669-002 01/01/2024

Rates Fringes

SPRINKLER FITTER.....\$ 45.31 27.91

SHEE0105-003 01/01/2024

LOS ANGELES (South of a straight line drawn between Gorman and
Big Pines)and Catalina Island, INYO, KERN (Northeast part, East
of Hwy 395), MONO ORANGE, RIVERSIDE, AND SAN BERNARDINO COUNTIES

Rates Fringes

SHEET METAL WORKER

(1) Commercial - New
Construction and Remodel
work.....\$ 56.95 30.04

(2) Industrial work including air pollution control systems, noise abatement, hand rails, guard rails, excluding aritechtrual sheet metal work, excluding A-C, heating, ventilating systems for human comfort...\$ 56.95 30.04

TEAM0011-002 07/01/2023

Rates Fringes

TRUCK DRIVER

GROUP 1.....	\$ 38.19	33.69
GROUP 2.....	\$ 38.34	33.69
GROUP 3.....	\$ 38.47	33.69
GROUP 4.....	\$ 38.66	33.69
GROUP 5.....	\$ 38.69	33.69
GROUP 6.....	\$ 38.72	33.69
GROUP 7.....	\$ 38.97	33.69
GROUP 8.....	\$ 39.22	33.69
GROUP 9.....	\$ 39.42	33.69
GROUP 10.....	\$ 39.72	33.69
GROUP 11.....	\$ 40.22	33.69
GROUP 12.....	\$ 40.65	33.69

WORK ON ALL MILITARY BASES:

PREMIUM PAY: \$3.00 per hour additional.

[29 palms Marine Base, Camp Roberts, China Lake, Edwards AFB, El Centro Naval Facility, Fort Irwin, Marine Corps Logistics Base at Nebo & Yermo, Mountain Warfare Training Center, Bridgeport, Point Arguello, Point Conception, Vandenberg AFB]

TRUCK DRIVERS CLASSIFICATIONS

GROUP 1: Truck driver

GROUP 2: Driver of vehicle or combination of vehicles - 2 axles; Traffic control pilot car excluding moving heavy equipment permit load; Truck mounted broom

GROUP 3: Driver of vehicle or combination of vehicles - 3 axles; Boot person; Cement mason distribution truck; Fuel truck driver; Water truck - 2 axle; Dump truck, less than 16 yds. water level; Erosion control driver

GROUP 4: Driver of transit mix truck, under 3 yds.; Dumpcrete truck, less than 6-1/2 yds. water level

GROUP 5: Water truck, 3 or more axles; Truck greaser and tire person (\$0.50 additional for tire person); Pipeline and utility working truck driver, including winch truck and plastic fusion, limited to pipeline and utility work; Slurry truck driver

GROUP 6: Transit mix truck, 3 yds. or more; Dumpcrete truck, 6-1/2 yds. water level and over; Vehicle or combination of vehicles - 4 or more axles; Oil spreader truck; Dump truck, 16 yds. to 25 yds. water level

GROUP 7: A Frame, Swedish crane or similar; Forklift driver; Ross carrier driver

GROUP 8: Dump truck, 25 yds. to 49 yds. water level; Truck repair person; Water pull - single engine; Welder

GROUP 9: Truck repair person/welder; Low bed driver, 9 axles or over

GROUP 10: Dump truck - 50 yds. or more water level; Water pull - single engine with attachment

GROUP 11: Water pull - twin engine; Water pull - twin engine with attachments; Winch truck driver - \$1.25 additional when operating winch or similar special attachments

GROUP 12: Boom Truck 17K and above

WELDERS - Receive rate prescribed for craft performing operation to which welding is incidental.

=====

Note: Executive Order (EO) 13706, Establishing Paid Sick Leave for Federal Contractors applies to all contracts subject to the Davis-Bacon Act for which the contract is awarded (and any solicitation was issued) on or after January 1, 2017. If this contract is covered by the EO, the contractor must provide employees with 1 hour of paid sick leave for every 30 hours they work, up to 56 hours of paid sick leave each year. Employees must be permitted to use paid sick leave for their own illness, injury or other health-related needs, including preventive care; to assist a family member (or person who is like family to the employee) who is ill, injured, or has other health-related needs, including preventive care; or for reasons resulting from, or to assist a family member (or person who is like family to the employee) who is a victim of, domestic violence, sexual assault, or stalking. Additional information on contractor requirements and worker protections under the EO is available at <https://www.dol.gov/agencies/whd/government-contracts>.

Unlisted classifications needed for work not included within the scope of the classifications listed may be added after award only as provided in the labor standards contract clauses (29CFR 5.5 (a) (1) (iii)).

The body of each wage determination lists the classification and wage rates that have been found to be prevailing for the cited type(s) of construction in the area covered by the wage determination. The classifications are listed in alphabetical order of ""identifiers"" that indicate whether the particular rate is a union rate (current union negotiated rate for local), a survey rate (weighted average rate) or a union average rate (weighted union average rate).

Union Rate Identifiers

A four letter classification abbreviation identifier enclosed in dotted lines beginning with characters other than ""SU"" or ""UAVG"" denotes that the union classification and rate were prevailing for that classification in the survey. Example: PLUM0198-005 07/01/2014. PLUM is an abbreviation identifier of the union which prevailed in the survey for this classification, which in this example would be Plumbers. 0198 indicates the local union number or district council number where applicable, i.e., Plumbers Local 0198. The next number, 005 in the example, is an internal number used in processing the wage determination. 07/01/2014 is the effective date of the most current negotiated rate, which in this example is July 1, 2014.

Union prevailing wage rates are updated to reflect all rate changes in the collective bargaining agreement (CBA) governing this classification and rate.

Survey Rate Identifiers

Classifications listed under the ""SU"" identifier indicate that no one rate prevailed for this classification in the survey and the published rate is derived by computing a weighted average rate based on all the rates reported in the survey for that classification. As this weighted average rate includes all rates reported in the survey, it may include both union and non-union rates. Example: SULA2012-007 5/13/2014. SU indicates the rates are survey rates based on a weighted average calculation of rates and are not majority rates. LA indicates the State of Louisiana. 2012 is the year of survey on which these classifications and rates are based. The next number, 007 in the example, is an internal number used in producing the wage determination. 5/13/2014 indicates the survey completion

date for the classifications and rates under that identifier.

Survey wage rates are not updated and remain in effect until a new survey is conducted.

Union Average Rate Identifiers

Classification(s) listed under the UAVG identifier indicate that no single majority rate prevailed for those classifications; however, 100% of the data reported for the classifications was union data. EXAMPLE: UAVG-OH-0010 08/29/2014. UAVG indicates that the rate is a weighted union average rate. OH indicates the state. The next number, 0010 in the example, is an internal number used in producing the wage determination. 08/29/2014 indicates the survey completion date for the classifications and rates under that identifier.

A UAVG rate will be updated once a year, usually in January of each year, to reflect a weighted average of the current negotiated/CBA rate of the union locals from which the rate is based.

WAGE DETERMINATION APPEALS PROCESS

1.) Has there been an initial decision in the matter? This can be:

- * an existing published wage determination
- * a survey underlying a wage determination
- * a Wage and Hour Division letter setting forth a position on a wage determination matter
- * a conformance (additional classification and rate) ruling

On survey related matters, initial contact, including requests for summaries of surveys, should be with the Wage and Hour National Office because National Office has responsibility for the Davis-Bacon survey program. If the response from this initial contact is not satisfactory, then the process described in 2.) and 3.) should be followed.

With regard to any other matter not yet ripe for the formal process described here, initial contact should be with the Branch of Construction Wage Determinations. Write to:

Branch of Construction Wage Determinations
Wage and Hour Division
U.S. Department of Labor
200 Constitution Avenue, N.W.
Washington, DC 20210

2.) If the answer to the question in 1.) is yes, then an interested party (those affected by the action) can request review and reconsideration from the Wage and Hour Administrator (See 29 CFR Part 1.8 and 29 CFR Part 7). Write to:

Wage and Hour Administrator
U.S. Department of Labor
200 Constitution Avenue, N.W.
Washington, DC 20210

The request should be accompanied by a full statement of the interested party's position and by any information (wage payment data, project description, area practice material, etc.) that the requestor considers relevant to the issue.

3.) If the decision of the Administrator is not favorable, an interested party may appeal directly to the Administrative Review Board (formerly the Wage Appeals Board). Write to:

Administrative Review Board
U.S. Department of Labor
200 Constitution Avenue, N.W.
Washington, DC 20210

4.) All decisions by the Administrative Review Board are final.

=====

END OF GENERAL DECISION"



Addendum No. 1 CIP R-24 Citywide Sidewalk Project

This addendum is for the purpose of adding, clarifying, or deleting certain information to the construction contract documents as follows:

Questions & Answers

1. Can the City provide the Engineer's estimate for the project?

City of Beaumont Response: The City does not provide an Engineer's estimate.

2. Does the City have a pole foundation detail for the relocation of the candlestick light poles? Does the contractor need to provide an engineered drawing for the new foundations?

City of Beaumont Response: The Pole detail is attached for reference. The contractor will provide a construction submittal for the foundations. The foundation for the poles is specified as follows:

All poles will have a thirty-inch round or square in-ground base with a depth of forty-eight (48) inches from top of curb, and a minimum forty-two (42) inches of concrete base depth. Washers will be installed above and below the one-inch pole-mounting flange. Anchor bolts, washers and nuts will all be hot dipped galvanized steel per pole manufacturer specifications. All poles are to be placed behind the curb with a center of pole measurement of eighteen (18) inches from the face of curb to the center of pole. Concrete for pole bases shall be a public works design mix with test strength of 3250 PSI.

3. Is the award limit on the project still \$520,000?

City of Beaumont Response: The award limit provided in the NIB and in the instruction to bidders has been **decreased**. The award limit for the project is now **\$484,000**. The contract award cannot be more than this amount.

Attachments

The following attachments are made a part of this addendum.

- Sign-in sheet from the Mandatory Pre-Bid Meeting held on March 6, 2024.
- Candlestick light pole detail



Dated: March 13, 2024

By: _____
(Bidder's Company Name)

Date Received by Bidder: _____
(Bidder's Signature)

_____ (Type or Print Name)

Bidder shall include a signed copy of this Addendum No. 1 with the bid proposal.

End of Addendum No. 1

CITY OF BEAUMONT

Project: CIP R-24 Citywide Sidewalk Project

Pre-Bid Meeting: Wednesday March 6, 2024 - 10:00 A.M.

ATTENDANCE REGISTER

PLEASE PRINT ALL INFORMATION

****Please provide a business card if available****

Contractor Name	Representative	Contractor Mailing Address	Telephone #
			Email
CPS LEGACY	Ramy Peciob	Gregg Strampf (951) 515-1322	(951) @greggstrampf@cpslegacy.com
CT&T CONCRETE PAVING	Ramon Rodriguez	JOSE CARVAJAL PMB. 275 324 S Diamond Bay Blvd	(909) 235-1513 ramon@cttconcretepaving.com
UNIVERSAL	Ramon Sanchez	P.O. Suite 210 77725 Entfield Lane	(760) 200-3100 -
THREE PEAKS CORP	SKIP MATTHEW for ERIK SIMMON	P.O. BOX 101 CALUMESA, CA 92320	(909) 522-2219 ERIK@THREEPEAKSCORP.COM
EBS GENERAL ENGINEERING	ELIJAH KELLER	1345 QUARRY ST. CORONA, CA, 92879	(909) (909) (909) 229-6533 BIDS@EBSGENERAL.COM
			()
			()
			()
			()
			()

REV.	ALTERATION	DATE	BY

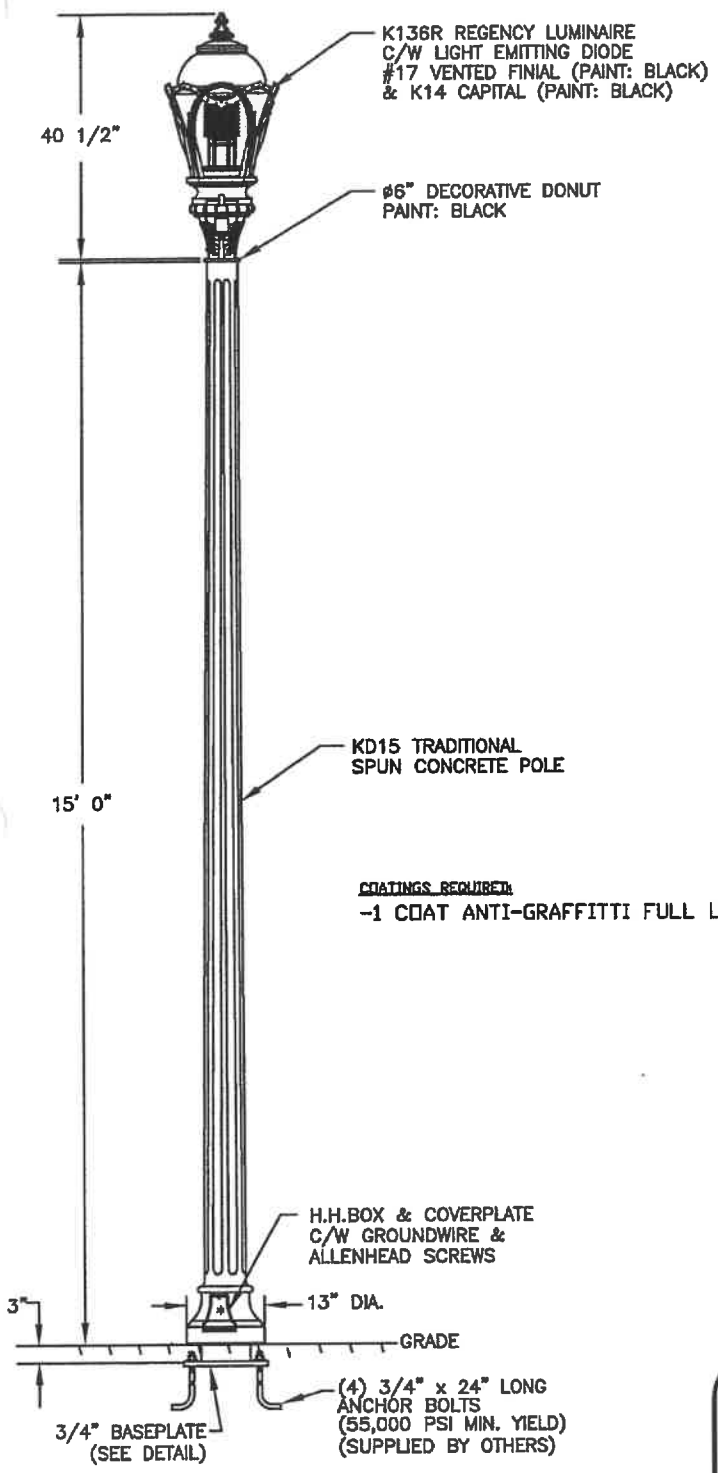

COATINGS REQUIRED:
-1 COAT ANTI-GRAFFITI FULL LENGTH

LUMINAIRE SPECIFICATIONS
 CATALOGUE NO.: K136R-BAR-III-78(SSL)
 -5000-240-K14-PR
 QUANTITY:
 GLOBE MOUNTING: ROTOLOCK
 OPTICAL SYSTEM: BAFFLED ACRYLIC RIPPLED
 IES CLASS.: TYPE III
 INPUT WATTAGE: 78W
 (SOLID STATE LIGHTING)
 SERIES: 5000
 INPUT VOLTAGE: 240V
 POLE ADAPTOR: K14
 PAINT: BLACK
 OPTIONS: TWISTLOCK RECEPTACLE
 (PHOTO EYE BY OTHERS)

LED INCLUDED
BALLAST SPECIFICATIONS
 SUPPLIED
 BALLAST TYPE: ELECTRONIC

OPTIONS
 TERMINAL BLOCK PLEASE SELECT ONE
 QUICK DISCONNECT
 OTHER

POLE SPECIFICATIONS:
 CATALOGUE NO.: KD15-G-E11-SBP
 C/W 140-35/40
 QUANTITY:
 SECTION: FLUTED ROUND
 COLOUR: ECLIPSE
 FINISH: ETCHED
 POLE TOP: #5"
 POLE BUTT: 14" FL/FL
 POLE LENGTH: 15' 0"
 APPROX. WEIGHT: 540 lbs.

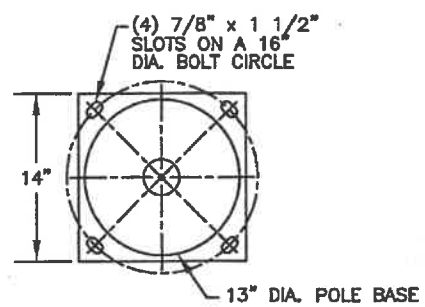

BASEPLATE DETAIL
 MAT'L: 3/4" x 14" x 14" GALV. STL.



King Luminaires • Stresscrete • Est. 1953

STRESSCRETE GROUP

Manufacturing Locations:
 Burlington, Ontario 1-800-268-7809
 Northport, Alabama 1-800-435-6563
 Atchison, Kansas 1-800-837-1024
 Jefferson, Ohio 1-800-268-7809

CUSTOMER ORDER No:	-
STRESSCRETE ORDER No:	-
KING CANADA ORDER No:	-
KING U.S. ORDER No:	-

PROJECT/CUSTOMER:				
CITY OF BEAUMONT, POLE TYPE BA				
DRAWN BY:	AT:	CHECKED BY:	DATE:	REVISION:
M.L.	SC1	<i>HL</i>	8/6/08	
DRAWING TYPE:			DRAWING NUMBER:	
CONCEPT DRAWING			206A4604-7A	



Addendum No. 2
CIP R-24 Citywide Sidewalk Improvements

This Addendum is for the purpose of adding, clarifying, or deleting certain information to the construction contract documents as follows:

Federal Wage Determination

The following shall be considered as incorporated into the Bid Specifications for the aforementioned project. Information not specifically mentioned in this Addendum shall remain in force.

- **Remove** Appendix B – Prevailing Wage Determination (CA20240025, **Modification 2** dated 1/19/2024); **Replace** with Appendix B – Wage Determination (CA20240025, **Modification 4** dated 3/8/2024).

Bidders are hereby notified; Addendum No. 2 must be acknowledged as stipulated in the Bid Specification instructions. Failure to do so shall result in the City designating such proposal as incomplete or "Non-Responsive".

APPROVED

A handwritten signature in black ink, appearing to read "Robert Vestal", is written over a horizontal line.

Robert Vestal, P.E.
Director of Public Works/City Engineer

End of Addendum No. 2

"General Decision Number: CA20240025 03/08/2024

Superseded General Decision Number: CA20230025

State: California

Construction Types: Building, Heavy (Heavy and Dredging) and Highway

County: Riverside County in California.

BUILDING CONSTRUCTION PROJECTS; DREDGING PROJECTS (does not include hopper dredge work); HEAVY CONSTRUCTION PROJECTS (does not include water well drilling); HIGHWAY CONSTRUCTION PROJECTS

Note: Contracts subject to the Davis-Bacon Act are generally required to pay at least the applicable minimum wage rate required under Executive Order 14026 or Executive Order 13658. Please note that these Executive Orders apply to covered contracts entered into by the federal government that are subject to the Davis-Bacon Act itself, but do not apply to contracts subject only to the Davis-Bacon Related Acts, including those set forth at 29 CFR 5.1(a)(1).

<p>If the contract is entered into on or after January 30, 2022, or the contract is renewed or extended (e.g., an option is exercised) on or after January 30, 2022:</p>	<ul style="list-style-type: none"> . Executive Order 14026 generally applies to the contract. . The contractor must pay all covered workers at least \$17.20 per hour (or the applicable wage rate listed on this wage determination, if it is higher) for all hours spent performing on the contract in 2024.
<p>If the contract was awarded on or between January 1, 2015 and January 29, 2022, and the contract is not renewed or extended on or after January 30, 2022:</p>	<ul style="list-style-type: none"> . Executive Order 13658 generally applies to the contract. . The contractor must pay all covered workers at least \$12.90 per hour (or the applicable wage rate listed on this wage determination, if it is higher) for all hours spent performing on that contract in 2024.

The applicable Executive Order minimum wage rate will be adjusted annually. If this contract is covered by one of the Executive Orders and a classification considered necessary for performance of work on the contract does not appear on this wage determination, the contractor must still submit a conformance request.

Additional information on contractor requirements and worker protections under the Executive Orders is available at <http://www.dol.gov/whd/govcontracts>.

Modification Number	Publication Date
0	01/05/2024
1	01/12/2024
2	01/19/2024
3	02/23/2024
4	03/08/2024

ASBE0005-002 09/01/2023

	Rates	Fringes
Asbestos Workers/Insulator (Includes the application of all insulating materials, protective coverings, coatings, and finishes to all types of mechanical systems).....	\$ 49.58	25.27
Fire Stop Technician (Application of Firestopping Materials for wall openings and penetrations in walls, floors, ceilings and curtain walls).....	\$ 36.97	20.36

ASBE0005-004 07/04/2022

	Rates	Fringes
Asbestos Removal worker/hazardous material handler (Includes preparation, wetting, stripping, removal, scrapping, vacuuming, bagging and disposing of all insulation materials from mechanical systems, whether they contain asbestos or not)....	\$ 23.52	13.37

BOIL0092-003 01/01/2024

	Rates	Fringes
BOILERMAKER.....	\$ 51.98	42.11

* BRCA0004-011 05/01/2020

	Rates	Fringes
BRICKLAYER; MARBLE SETTER.....	\$ 41.48	18.63

*The wage scale for prevailing wage projects performed in Blythe, China lake, Death Valley, Fort Irwin, Twenty-Nine Palms, Needles and 1-15 corridor (Barstow to the Nevada State Line) will be Three Dollars (\$3.00) above the standard San Bernardino/Riverside County hourly wage rate

BRCA0018-004 06/01/2022

	Rates	Fringes
MARBLE FINISHER.....	\$ 37.87	14.13
TILE FINISHER.....	\$ 32.44	12.54
TILE LAYER.....	\$ 45.05	18.33

BRCA0018-010 09/01/2022

	Rates	Fringes
TERRAZZO FINISHER.....	\$ 38.37	14.13
TERRAZZO WORKER/SETTER.....	\$ 46.49	14.66

CARP0213-001 07/01/2021

	Rates	Fringes
CARPENTER		
(1) Carpenter, Cabinet Installer, Insulation Installer, Hardwood Floor Worker and acoustical installer.....	\$ 51.60	16.28
(2) Millwright.....	\$ 52.10	16.48
(3) Piledrivermen/Derrick Bargeman, Bridge or Dock Carpenter, Heavy Framer, Rock Bargeman or Scowman, Rockslinger, Shingler (Commercial).....	\$ 51.73	16.28
(4) Pneumatic Nailer, Power Stapler.....	\$ 51.85	16.28
(5) Sawfiler.....	\$ 51.69	16.28
(6) Scaffold Builder.....	\$ 42.80	16.28
(7) Table Power Saw Operator.....	\$ 51.70	16.28

FOOTNOTE: Work of forming in the construction of open cut sewers or storm drains, on operations in which horizontal lagging is used in conjunction with steel H-Beams driven or placed in pre- drilled holes, for that portion of a lagged trench against which concrete is poured, namely, as a substitute for back forms (which work is performed by piledrivers): \$0.13 per hour additional.

CARP0213-002 07/01/2021

	Rates	Fringes
Diver		
(1) Wet.....	\$ 834.40	16.28
(2) Standby.....	\$ 445.84	16.28
(3) Tender.....	\$ 437.84	16.28
(4) Assistant Tender.....	\$ 413.84	16.28

Amounts in "'Rates' column are per day

CARP0213-004 07/01/2021

	Rates	Fringes
Drywall		
DRYWALL INSTALLER/LATHER....	\$ 51.60	16.28
STOCKER/SCRAPPER.....	\$ 22.16	8.62

CARP0721-001 07/01/2021

Rates	Fringes
-------	---------

Modular Furniture Installer.....\$ 21.85 7.15

ELEC0440-001 01/01/2024

Rates Fringes

ELECTRICIAN

INSIDE ELECTRICIAN.....\$ 53.76 3%+27.50

INTELLIGENT TRANSPORTATION
SYSTEMS

Electrician.....\$ 36.99 3%+23.18

Technician.....\$ 27.75 3%+23.18

ZONE PAY: Zone A: Free travel zone for all contractors performing work in Zone A.

Zone B:Any work performed in Zone (B) shall add \$12.00 per hour to the current wage scale. Zone (B) shall be the area from the eastern perimeter of Zone (A) to a line which runs north and south begining at Little Morongo Canyon (San Bernardino/Riverside County Line), Southeast along the Coachella Tunnels, Colorado River Aqueduct and Mecca Tunnels to Pinkham Wash then South to Box Canyon Road, then southwest along Box Canyon Road to Highway 195 west onto 195 south to Highway 86 to Riverside/Imperial County Line.

ELEC1245-001 06/01/2022

Rates Fringes

LINE CONSTRUCTION

(1) Lineman; Cable splicer..\$ 64.40 22.58

(2) Equipment specialist
(operates crawler tractors, commercial motor vehicles, backhoes, trenchers, cranes (50 tons and below), overhead & underground distribution

line equipment).....\$ 50.00 21.30

(3) Groundman.....\$ 38.23 20.89

(4) Powderman.....\$ 51.87 18.79

HOLIDAYS: New Year's Day, M.L. King Day, Memorial Day, Independence Day, Labor Day, Veterans Day, Thanksgiving Day and day after Thanksgiving, Christmas Day

ELEV0018-001 01/01/2024

Rates Fringes

ELEVATOR MECHANIC.....\$ 66.63 37.885+a+b

FOOTNOTE:

a. PAID VACATION: Employer contributes 8% of regular hourly rate as vacation pay credit for employees with more than 5 years of service, and 6% for 6 months to 5 years of service.

b. PAID HOLIDAYS: New Year's Day, Memorial Day, Independence Day, Labor Day, Veterans' Day, Thanksgiving Day, Friday after Thanksgiving, and Christmas Day.

ENGI0012-004 08/01/2023

	Rates	Fringes
OPERATOR: Power Equipment (DREDGING)		
(1) Leverman.....	\$ 64.10	34.60
(2) Dredge dozer.....	\$ 58.13	34.60
(3) Deckmate.....	\$ 58.02	34.60
(4) Winch operator (stern winch on dredge).....	\$ 57.47	34.60
(5) Fireman-Oiler, Deckhand, Bargeman, Leveehand.....	\$ 56.93	34.60
(6) Barge Mate.....	\$ 57.54	34.60

ENGI0012-024 07/01/2023

	Rates	Fringes
OPERATOR: Power Equipment (All Other Work)		
GROUP 1.....	\$ 53.90	32.80
GROUP 2.....	\$ 54.68	32.80
GROUP 3.....	\$ 54.97	32.80
GROUP 4.....	\$ 56.46	32.80
GROUP 6.....	\$ 56.68	32.80
GROUP 8.....	\$ 56.79	32.80
GROUP 10.....	\$ 56.91	32.80
GROUP 12.....	\$ 57.08	32.80
GROUP 13.....	\$ 57.18	32.80
GROUP 14.....	\$ 57.21	32.80
GROUP 15.....	\$ 57.29	32.80
GROUP 16.....	\$ 57.41	32.80
GROUP 17.....	\$ 57.58	32.80
GROUP 18.....	\$ 57.68	32.80
GROUP 19.....	\$ 57.79	32.80
GROUP 20.....	\$ 57.91	32.80
GROUP 21.....	\$ 58.08	32.80
GROUP 22.....	\$ 58.18	32.80
GROUP 23.....	\$ 58.29	32.80
GROUP 24.....	\$ 58.41	32.80
GROUP 25.....	\$ 58.58	32.80

OPERATOR: Power Equipment (Cranes, Piledriving & Hoisting)		
GROUP 1.....	\$ 55.25	32.80
GROUP 2.....	\$ 56.03	32.80
GROUP 3.....	\$ 56.32	32.80
GROUP 4.....	\$ 56.46	32.80
GROUP 5.....	\$ 56.68	32.80
GROUP 6.....	\$ 56.79	32.80
GROUP 7.....	\$ 56.91	32.80
GROUP 8.....	\$ 57.08	32.80
GROUP 9.....	\$ 57.25	32.80
GROUP 10.....	\$ 58.25	32.80
GROUP 11.....	\$ 59.25	32.80
GROUP 12.....	\$ 60.25	32.80
GROUP 13.....	\$ 61.25	32.80

OPERATOR: Power Equipment (Tunnel Work)		
GROUP 1.....	\$ 55.75	32.80
GROUP 2.....	\$ 56.53	32.80
GROUP 3.....	\$ 56.82	32.80
GROUP 4.....	\$ 56.96	32.80
GROUP 5.....	\$ 57.18	32.80

GROUP 6.....	\$ 57.29	32.80
GROUP 7.....	\$ 57.41	32.80

PREMIUM PAY:

\$10.00 per hour shall be paid on all Power Equipment Operator work on the following Military Bases: China Lake Naval Reserve, Vandenberg AFB, Point Arguello, Seely Naval Base, Fort Irwin, Nebo Annex Marine Base, Marine Corp Logistics Base Yermo, Edwards AFB, 29 Palms Marine Base and Camp Pendleton

Workers required to suit up and work in a hazardous material environment: \$2.00 per hour additional. Combination mixer and compressor operator on gunite work shall be classified as a concrete mobile mixer operator.

SEE ZONE DEFINITIONS AFTER CLASSIFICATIONS**POWER EQUIPMENT OPERATORS CLASSIFICATIONS**

GROUP 1: Bargeman; Brakeman; Compressor operator; Ditch Witch, with seat or similar type equipment; Elevator operator-inside; Engineer Oiler; Forklift operator (includes loed, lull or similar types under 5 tons; Generator operator; Generator, pump or compressor plant operator; Pump operator; Signalman; Switchman

GROUP 2: Asphalt-rubber plant operator (nurse tank operator); Coil Tubing Rig Operator, Concrete mixer operator-skip type; Conveyor operator; Fireman; Forklift operator (includes loed, lull or similar types over 5 tons; Hydrostatic pump operator; oiler crusher (asphalt or concrete plant); Petromat laydown machine; PJU side dum jack; Screening and conveyor machine operator (or similar types); Skiploader (wheel type up to 3/4 yd. without attachment); Tar pot fireman; Temporary heating plant operator; Trenching machine oiler

GROUP 3: Asphalt-rubber blend operator; Bobcat or similar type (Skid steer); Equipment greaser (rack); Ford Ferguson (with dragtype attachments); Helicopter radioman (ground); Stationary pipe wrapping and cleaning machine operator

GROUP 4: Asphalt plant fireman; Backhoe operator (mini-max or similar type); Boring machine operator; Boxman or mixerman (asphalt or concrete); Chip spreading machine operator; Concrete cleaning decontamination machine operator; Concrete Pump Operator (small portable); Direct Push Operator (Geoprobe or similar types) Drilling machine operator, small auger types (Texoma super economatic or similar types - Hughes 100 or 200 or similar types - drilling depth of 30' maximum); Equipment greaser (grease truck); Guard rail post driver operator; Highline cableway signalman; Hydra-hammer-aero stomper; Micro Tunneling (above ground tunnel); Power concrete curing machine operator; Power concrete saw operator; Power-driven jumbo form setter operator; Power sweeper operator; Rock Wheel Saw/Trencher; Roller operator (compacting); Screed operator (asphalt or concrete); Trenching machine operator (up to 6 ft.); Vacuum or much truck

GROUP 6: Articulating material hauler; Asphalt plant engineer; Batch plant operator; Bit sharpener; Concrete joint machine operator (canal and similar type); Concrete

planer operator; Dandy digger; Deck engine operator; Derrickman (oilfield type); Drilling machine operator, bucket or auger types (Calweld 100 bucket or similar types - Watson 1000 auger or similar types - Texoma 330, 500 or 600 auger or similar types - drilling depth of 45' maximum); Drilling machine operator; Hydrographic seeder machine operator (straw, pulp or seed), Jackson track maintainer, or similar type; Kalamazoo Switch tamper, or similar type; Machine tool operator; Maginnis internal full slab vibrator, Mechanical berm, curb or gutter (concrete or asphalt); Mechanical finisher operator (concrete, Clary-Johnson-Bidwell or similar); Micro tunnel system (below ground); Pavement breaker operator (truck mounted); Road oil mixing machine operator; Roller operator (asphalt or finish), rubber-tired earth moving equipment (single engine, up to and including 25 yds. struck); Self-propelled tar pipelining machine operator; Skiploader operator (crawler and wheel type, over 3/4 yd. and up to and including 1-1/2 yds.); Slip form pump operator (power driven hydraulic lifting device for concrete forms); Tractor operator-bulldozer, tamper-scraper (single engine, up to 100 h.p. flywheel and similar types, up to and including D-5 and similar types); Tugger hoist operator (1 drum); Ultra high pressure waterjet cutting tool system operator; Vacuum blasting machine operator

GROUP 8: Asphalt or concrete spreading operator (tamping or finishing); Asphalt paving machine operator (Barber Greene or similar type); Asphalt-rubber distribution operator; Backhoe operator (up to and including 3/4 yd.), small ford, Case or similar types; Cable Bundling Machine Operator (excluding handheld); Cable Trenching Machine Operator (Spider Plow or similar types) Cast-in-place pipe laying machine operator; Combination mixer and compressor operator (gunite work); Compactor operator (self-propelled); Concrete mixer operator (paving); Crushing plant operator; Drill Doctor; Drilling machine operator, Bucket or auger types (Calweld 150 bucket or similar types - Watson 1500, 2000 2500 auger or similar types - Texoma 700, 800 auger or similar types - drilling depth of 60' maximum); Elevating grader operator; Grade checker; Gradall operator; Grouting machine operator; Heavy-duty repairman; Heavy equipment robotics operator; Kalamazoo balliste regulator or similar type; Kolman belt loader and similar type; Le Tourneau blob compactor or similar type; Loader operator (Athey, Euclid, Sierra and similar types); Mobark Chipper or similar; Ozzie padder or similar types; P.C. slot saw; Pneumatic concrete placing machine operator (Hackley-Presswell or similar type); Pumpcrete gun operator; RCM Cementing Unit Operator, Rail/Switch Grinder Operator (Harsco or similar types) Rock Drill or similar types; Rotary drill operator (excluding caisson type); Rubber-tired earth-moving equipment operator (single engine, caterpillar, Euclid, Athey Wagon and similar types with any and all attachments over 25 yds. up to and including 50 cu. yds. struck); Rubber-tired earth-moving equipment operator (multiple engine up to and including 25 yds. struck); Rubber-tired scraper operator (self-loading paddle wheel type-John Deere, 1040 and similar single unit); Self-propelled curb and gutter machine operator; Shuttle buggy; Skiploader operator (crawler and wheel type over 1-1/2 yds. up to and including 6-1/2 yds.); Soil remediation plant operator; Surface heaters and planer operator; Tractor compressor drill combination operator; Tractor operator (any type larger than D-5 - 100 flywheel h.p. and over, or

similar-bulldozer, tamper, scraper and push tractor single engine); Tractor operator (boom attachments), Traveling pipe wrapping, cleaning and bending machine operator; Trenching machine operator (over 6 ft. depth capacity, manufacturer's rating); trenching Machine with Road Miner attachment (over 6 ft depth capacity): Ultra high pressure waterjet cutting tool system mechanic; Water pull (compaction) operator

GROUP 10: Drilling machine operator, Bucket or auger types (Calweld 200 B bucket or similar types-Watson 3000 or 5000 auger or similar types-Texoma 900 auger or similar types-drilling depth of 105' maximum); Dual drum mixer, dynamic compactor LDC350 (or similar types); Monorail locomotive operator (diesel, gas or electric); Motor patrol-blade operator (single engine); Multiple engine tractor operator (Euclid and similar type-except Quad 9 cat.); Rubber-tired earth-moving equipment operator (single engine, over 50 yds. struck); Pneumatic pipe ramming tool and similar types; Prestressed wrapping machine operator; Rubber-tired earth-moving equipment operator (single engine, over 50 yds. struck); Rubber tired earth moving equipment operator (multiple engine, Euclid, caterpillar and similar over 25 yds. and up to 50 yds. struck), Tower crane repairman; Tractor loader operator (crawler and wheel type over 6-1/2 yds.); Woods mixer operator (and similar Pugmill equipment)

GROUP 12: Auto grader operator; Automatic slip form operator; Drilling machine operator, bucket or auger types (Calweld, auger 200 CA or similar types - Watson, auger 6000 or similar types - Hughes Super Duty, auger 200 or similar types - drilling depth of 175' maximum); Hoe ram or similar with compressor; Mass excavator operator less tha 750 cu. yards; Mechanical finishing machine operator; Mobile form traveler operator; Motor patrol operator (multi-engine); Pipe mobile machine operator; Rubber-tired earth- moving equipment operator (multiple engine, Euclid, Caterpillar and similar type, over 50 cu. yds. struck); Rubber-tired self- loading scraper operator (paddle-wheel-auger type self-loading - two (2) or more units)

GROUP 13: Rubber-tired earth-moving equipment operator operating equipment with push-pull system (single engine, up to and including 25 yds. struck)

GROUP 14: Canal liner operator; Canal trimmer operator; Remote- control earth-moving equipment operator (operating a second piece of equipment: \$1.00 per hour additional); Wheel excavator operator (over 750 cu. yds.)

GROUP 15: Rubber-tired earth-moving equipment operator, operating equipment with push-pull system (single engine, Caterpillar, Euclid, Athey Wagon and similar types with any and all attachments over 25 yds. and up to and including 50 yds. struck); Rubber-tired earth-moving equipment operator, operating equipment with push-pull system (multiple engine-up to and including 25 yds. struck)

GROUP 16: Rubber-tired earth-moving equipment operator, operating equipment with push-pull system (single engine, over 50 yds. struck); Rubber-tired earth-moving equipment operator, operating equipment with push-pull system (multiple engine, Euclid, Caterpillar and similar, over 25 yds. and up to 50 yds. struck)

GROUP 17: Rubber-tired earth-moving equipment operator, operating equipment with push-pull system (multiple engine, Euclid, Caterpillar and similar, over 50 cu. yds. struck); Tandem tractor operator (operating crawler type tractors in tandem - Quad 9 and similar type)

GROUP 18: Rubber-tired earth-moving equipment operator, operating in tandem (scrapers, belly dumps and similar types in any combination, excluding compaction units - single engine, up to and including 25 yds. struck)

GROUP 19: Rotex concrete belt operator (or similar types); Rubber-tired earth-moving equipment operator, operating in tandem (scrapers, belly dumps and similar types in any combination, excluding compaction units - single engine, Caterpillar, Euclid, Athey Wagon and similar types with any and all attachments over 25 yds. and up to and including 50 cu. yds. struck); Rubber-tired earth-moving equipment operator, operating in tandem (scrapers, belly dumps and similar types in any combination, excluding compaction units - multiple engine, up to and including 25 yds. struck)

GROUP 20: Rubber-tired earth-moving equipment operator, operating in tandem (scrapers, belly dumps and similar types in any combination, excluding compaction units - single engine, over 50 yds. struck); Rubber-tired earth-moving equipment operator, operating in tandem (scrapers, belly dumps, and similar types in any combination, excluding compaction units - multiple engine, Euclid, Caterpillar and similar, over 25 yds. and up to 50 yds. struck)

GROUP 21: Rubber-tired earth-moving equipment operator, operating in tandem (scrapers, belly dumps and similar types in any combination, excluding compaction units - multiple engine, Euclid, Caterpillar and similar type, over 50 cu. yds. struck)

GROUP 22: Rubber-tired earth-moving equipment operator, operating equipment with the tandem push-pull system (single engine, up to and including 25 yds. struck)

GROUP 23: Rubber-tired earth-moving equipment operator, operating equipment with the tandem push-pull system (single engine, Caterpillar, Euclid, Athey Wagon and similar types with any and all attachments over 25 yds. and up to and including 50 yds. struck); Rubber-tired earth-moving equipment operator, operating with the tandem push-pull system (multiple engine, up to and including 25 yds. struck)

GROUP 24: Rubber-tired earth-moving equipment operator, operating equipment with the tandem push-pull system (single engine, over 50 yds. struck); Rubber-tired earth-moving equipment operator, operating equipment with the tandem push-pull system (multiple engine, Euclid, Caterpillar and similar, over 25 yds. and up to 50 yds. struck)

GROUP 25: Concrete pump operator-truck mounted; Rubber-tired earth-moving equipment operator, operating equipment with the tandem push-pull system (multiple engine, Euclid, Caterpillar and similar type, over 50 cu. yds. struck); Spyder Excavator Operator, with all attachments

CRANES, PILEDRIVING AND HOISTING EQUIPMENT CLASSIFICATIONS

GROUP 1: Engineer oiler; Fork lift operator (includes loed, lull or similar types)

GROUP 2: Truck crane oiler

GROUP 3: A-frame or winch truck operator; Ross carrier operator (jobsite)

GROUP 4: Bridge-type unloader and turntable operator; Helicopter hoist operator

GROUP 5: Hydraulic boom truck; Stinger crane (Austin-Western or similar type); Tugger hoist operator (1 drum)

GROUP 6: Bridge crane operator; Cretor crane operator; Hoist operator (Chicago boom and similar type); Lift mobile operator; Lift slab machine operator (Vagtborg and similar types); Material hoist and/or manlift operator; Polar gantry crane operator; Self Climbing scaffold (or similar type); Shovel, backhoe, dragline, clamshell operator (over 3/4 yd. and up to 5 cu. yds. mrc); Tugger hoist operator

GROUP 7: Pedestal crane operator; Shovel, backhoe, dragline, clamshell operator (over 5 cu. yds. mrc); Tower crane repair; Tugger hoist operator (3 drum)

GROUP 8: Crane operator (up to and including 25 ton capacity); Crawler transporter operator; Derrick barge operator (up to and including 25 ton capacity); Hoist operator, stiff legs, Guy derrick or similar type (up to and including 25 ton capacity); Shovel, backhoe, dragline, clamshell operator (over 7 cu. yds., M.R.C.)

GROUP 9: Crane operator (over 25 tons and up to and including 50 tons mrc); Derrick barge operator (over 25 tons up to and including 50 tons mrc); Highline cableway operator; Hoist operator, stiff legs, Guy derrick or similar type (over 25 tons up to and including 50 tons mrc); K-crane operator; Polar crane operator; Self erecting tower crane operator maximum lifting capacity ten tons

GROUP 10: Crane operator (over 50 tons and up to and including 100 tons mrc); Derrick barge operator (over 50 tons up to and including 100 tons mrc); Hoist operator, stiff legs, Guy derrick or similar type (over 50 tons up to and including 100 tons mrc), Mobile tower crane operator (over 50 tons, up to and including 100 tons M.R.C.);

GROUP 11: Crane operator (over 100 tons and up to and including 200 tons mrc); Derrick barge operator (over 100 tons up to and including 200 tons mrc); Hoist operator, stiff legs, Guy derrick or similar type (over 100 tons up to and including 200 tons mrc); Mobile tower crane operator (over 100 tons up to and including 200 tons mrc) ; Tower crane operator and tower gantry

GROUP 12: Crane operator (over 200 tons up to and including 300 tons mrc); Derrick barge operator (over 200 tons up to and including 300 tons mrc); Hoist operator, stiff legs, Guy derrick or similar type (over 200 tons, up to and including 300 tons mrc); Mobile tower crane operator (over 200 tons, up to and including 300 tons mrc)

GROUP 13: Crane operator (over 300 tons); Derrick barge operator (over 300 tons); Helicopter pilot; Hoist operator, stiff legs, Guy derrick or similar type (over 300 tons); Mobile tower crane operator (over 300 tons)

TUNNEL CLASSIFICATIONS

GROUP 1: Skiploader (wheel type up to 3/4 yd. without attachment)

GROUP 2: Power-driven jumbo form setter operator

GROUP 3: Dinkey locomotive or motorperson (up to and including 10 tons)

GROUP 4: Bit sharpener; Equipment greaser (grease truck); Slip form pump operator (power-driven hydraulic lifting device for concrete forms); Tugger hoist operator (1 drum); Tunnel locomotive operator (over 10 and up to and including 30 tons)

GROUP 5: Backhoe operator (up to and including 3/4 yd.); Small Ford, Case or similar; Drill doctor; Grouting machine operator; Heading shield operator; Heavy-duty repairperson; Loader operator (Athey, Euclid, Sierra and similar types); Mucking machine operator (1/4 yd., rubber-tired, rail or track type); Pneumatic concrete placing machine operator (Hackley-Presswell or similar type); Pneumatic heading shield (tunnel); Pumpcrete gun operator; Tractor compressor drill combination operator; Tugger hoist operator (2 drum); Tunnel locomotive operator (over 30 tons)

GROUP 6: Heavy Duty Repairman

GROUP 7: Tunnel mole boring machine operator

ENGINEERS ZONES

\$1.00 additional per hour for all of IMPERIAL County and the portions of KERN, RIVERSIDE & SAN BERNARDINO Counties as defined below:

That area within the following Boundary: Begin in San Bernardino County, approximately 3 miles NE of the intersection of I-15 and the California State line at that point which is the NW corner of Section 1, T17N,m R14E, San Bernardino Meridian. Continue W in a straight line to that point which is the SW corner of the northwest quarter of Section 6, T27S, R42E, Mt. Diablo Meridian. Continue North to the intersection with the Inyo County Boundary at that point which is the NE corner of the western half of the northern quarter of Section 6, T25S, R42E, MDM. Continue W along the Inyo and San Bernardino County boundary until the intersection with Kern County, as that point which is the SE corner of Section 34, T24S, R40E, MDM. Continue W along the Inyo and Kern County boundary until the intersection with Tulare County, at that point which is the SW corner of the SE quarter of Section 32, T24S, R37E, MDM. Continue W along the Kern and Tulare County boundary, until that point which is the NW corner of T25S, R32E, MDM. Continue S following R32E lines to the NW corner of T31S, R32E, MDM. Continue W to the NW corner of T31S, R31E, MDM. Continue S to the SW corner of T32S, R31E, MDM. Continue W to SW corner of SE quarter of Section 34, T32S, R30E, MDM. Continue S to SW corner of T11N, R17W, SBM. Continue E along

south boundary of T11N, SBM to SW corner of T11N, R7W, SBM. Continue S to SW corner of T9N, R7W, SBM. Continue E along south boundary of T9N, SBM to SW corner of T9N, R1E, SBM. Continue S along west boundary of R1E, SBM to Riverside County line at the SW corner of T1S, R1E, SBM. Continue E along south boundary of T1s, SBM (Riverside County Line) to SW corner of T1S, R10E, SBM. Continue S along west boundary of R10E, SBM to Imperial County line at the SW corner of T8S, R10E, SBM. Continue W along Imperial and Riverside county line to NW corner of T9S, R9E, SBM. Continue S along the boundary between Imperial and San Diego Counties, along the west edge of R9E, SBM to the south boundary of Imperial County/California state line. Follow the California state line west to Arizona state line, then north to Nevada state line, then continuing NW back to start at the point which is the NW corner of Section 1, T17N, R14E, SBM

\$1.00 additional per hour for portions of SAN LUIS OBISPO, KERN, SANTA BARBARA & VENTURA as defined below:

That area within the following Boundary: Begin approximately 5 miles north of the community of Cholame, on the Monterey County and San Luis Obispo County boundary at the NW corner of T25S, R16E, Mt. Diablo Meridian. Continue south along the west side of R16E to the SW corner of T30S, R16E, MDM. Continue E to SW corner of T30S, R17E, MDM. Continue S to SW corner of T31S, R17E, MDM. Continue E to SW corner of T31S, R18E, MDM. Continue S along West side of R18E, MDM as it crosses into San Bernardino Meridian numbering area and becomes R30W. Follow the west side of R30W, SBM to the SW corner of T9N, R30W, SBM. Continue E along the south edge of T9N, SBM to the Santa Barbara County and Ventura County boundary at that point which is the SW corner of Section 34.T9N, R24W, SBM, continue S along the Ventura County line to that point which is the SW corner of the SE quarter of Section 32, T7N, R24W, SBM. Continue E along the south edge of T7N, SBM to the SE corner to T7N, R21W, SBM. Continue N along East side of R21W, SBM to Ventura County and Kern County boundary at the NE corner of T8N, R21W. Continue W along the Ventura County and Kern County boundary to the SE corner of T9N, R21W. Continue North along the East edge of R21W, SBM to the NE corner of T12N, R21W, SBM. Continue West along the north edge of T12N, SBM to the SE corner of T32S, R21E, MDM. [T12N SBM is a thin strip between T11N SBM and T32S MDM]. Continue North along the East side of R21E, MDM to the Kings County and Kern County border at the NE corner of T25S, R21E, MDM, continue West along the Kings County and Kern County Boundary until the intersection of San Luis Obispo County. Continue west along the Kings County and San Luis Obispo County boundary until the intersection with Monterey County. Continue West along the Monterey County and San Luis Obispo County boundary to the beginning point at the NW corner of T25S, R16E, MDM.

\$2.00 additional per hour for INYO and MONO Counties and the Northern portion of SAN BERNARDINO County as defined below:

That area within the following Boundary: Begin at the intersection of the northern boundary of Mono County and the California state line at the point which is the center of Section 17, T10N, R22E, Mt. Diablo Meridian. Continue S then SE along the entire western boundary of Mono County, until it reaches Inyo County at the point which is the NE corner of the Western half of the NW quarter of Section 2, T8S, R29E, MDM. Continue SSE along the entire western boundary of Inyo County,

until the intersection with Kern County at the point which is the SW corner of the SE 1/4 of Section 32, T24S, R37E, MDM. Continue E along the Inyo and Kern County boundary until the intersection with San Bernardino County at that point which is the SE corner of section 34, T24S, R40E, MDM. Continue E along the Inyo and San Bernardino County boundary until the point which is the NE corner of the Western half of the NW quarter of Section 6, T25S, R42E, MDM. Continue S to that point which is the SW corner of the NW quarter of Section 6, T27S, R42E, MDM. Continue E in a straight line to the California and Nevada state border at the point which is the NW corner of Section 1, T17N, R14E, San Bernardino Meridian. Then continue NW along the state line to the starting point, which is the center of Section 18, T10N, R22E, MDM.

REMAINING AREA NOT DEFINED ABOVE RECIEVES BASE RATE

IRON0433-006 01/01/2024

	Rates	Fringes
IRONWORKER		
Fence Erector.....	\$ 42.53	26.26
Ornamental, Reinforcing and Structural.....	\$ 47.45	34.90

PREMIUM PAY:

\$9.00 additional per hour at the following locations:

China Lake Naval Test Station, Chocolate Mountains Naval Reserve-Niland, Edwards AFB, Fort Irwin Military Station, Fort Irwin Training Center-Goldstone, San Clemente Island, San Nicholas Island, Susanville Federal Prison, 29 Palms - Marine Corps, U.S. Marine Base - Barstow, U.S. Naval Air Facility - Sealey, Vandenberg AFB Army Defense Language Institute - Monterey, Fallon Air Base, Naval Post Graduate School - Monterey, Yermo Marine Corps Logistics Center
Port Hueneme, Port Mugu, U.S. Coast Guard Station - Two Rock

LAB00300-005 08/01/2022

	Rates	Fringes
Asbestos Removal Laborer.....	\$ 39.23	23.28

SCOPE OF WORK: Includes site mobilization, initial site cleanup, site preparation, removal of asbestos-containing material and toxic waste, encapsulation, enclosure and disposal of asbestos- containing materials and toxic waste by hand or with equipment or machinery; scaffolding, fabrication of temporary wooden barriers and assembly of decontamination stations.

LAB00345-001 07/01/2022

	Rates	Fringes
LABORER (GUNITE)		

GROUP 1.....	\$ 48.50	21.37
GROUP 2.....	\$ 47.55	21.37
GROUP 3.....	\$ 44.01	21.37

FOOTNOTE: GUNITE PREMIUM PAY: Workers working from a Bosn'n's Chair or suspended from a rope or cable shall receive 40 cents per hour above the foregoing applicable classification rates. Workers doing gunite and/or shotcrete work in a tunnel shall receive 35 cents per hour above the foregoing applicable classification rates, paid on a portal-to-portal basis. Any work performed on, in or above any smoke stack, silo, storage elevator or similar type of structure, when such structure is in excess of 75'-0"" above base level and which work must be performed in whole or in part more than 75'-0"" above base level, that work performed above the 75'-0"" level shall be compensated for at 35 cents per hour above the applicable classification wage rate.

GUNITE LABORER CLASSIFICATIONS

GROUP 1: Rodmen, Nozzlemen

GROUP 2: Gunmen

GROUP 3: Reboundmen

 LAB01184-001 07/01/2022

	Rates	Fringes
Laborers: (HORIZONTAL DIRECTIONAL DRILLING)		
(1) Drilling Crew Laborer...	\$ 40.69	18.25
(2) Vehicle Operator/Hauler.	\$ 40.86	18.25
(3) Horizontal Directional Drill Operator.....	\$ 42.71	18.25
(4) Electronic Tracking Locator.....	\$ 44.71	18.25
Laborers: (STRIPING/SLURRY SEAL)		
GROUP 1.....	\$ 41.90	21.32
GROUP 2.....	\$ 43.20	21.32
GROUP 3.....	\$ 45.21	21.32
GROUP 4.....	\$ 46.95	21.32

LABORERS - STRIPING CLASSIFICATIONS

GROUP 1: Protective coating, pavement sealing, including repair and filling of cracks by any method on any surface in parking lots, game courts and playgrounds; carstops; operation of all related machinery and equipment; equipment repair technician

GROUP 2: Traffic surface abrasive blaster; pot tender - removal of all traffic lines and markings by any method (sandblasting, waterblasting, grinding, etc.) and preparation of surface for coatings. Traffic control person: controlling and directing traffic through both conventional and moving lane closures; operation of all related machinery and equipment

GROUP 3: Traffic delineating device applicator: Layout and application of pavement markers, delineating signs, rumble

and traffic bars, adhesives, guide markers, other traffic delineating devices including traffic control. This category includes all traffic related surface preparation (sandblasting, waterblasting, grinding) as part of the application process. Traffic protective delineating system installer: removes, relocates, installs, permanently affixed roadside and parking delineation barricades, fencing, cable anchor, guard rail, reference signs, monument markers; operation of all related machinery and equipment; power broom sweeper

GROUP 4: Striper: layout and application of traffic stripes and markings; hot thermo plastic; tape traffic stripes and markings, including traffic control; operation of all related machinery and equipment

LAB01184-002 07/01/2022

	Rates	Fringes
LABORER (TUNNEL)		
GROUP 1.....	\$ 45.68	23.30
GROUP 2.....	\$ 46.00	23.30
GROUP 3.....	\$ 46.46	23.30
GROUP 4.....	\$ 47.15	23.30
LABORER		
GROUP 1.....	\$ 36.39	21.04
GROUP 2.....	\$ 36.94	21.04
GROUP 3.....	\$ 37.49	21.04
GROUP 4.....	\$ 39.04	21.04
GROUP 5.....	\$ 39.39	21.04

LABORER CLASSIFICATIONS

GROUP 1: Cleaning and handling of panel forms; Concrete screeding for rough strike-off; Concrete, water curing; Demolition laborer, the cleaning of brick if performed by a worker performing any other phase of demolition work, and the cleaning of lumber; Fire watcher, limber, brush loader, piler and debris handler; Flag person; Gas, oil and/or water pipeline laborer; Laborer, asphalt-rubber material loader; Laborer, general or construction; Laborer, general clean-up; Laborer, landscaping; Laborer, jetting; Laborer, temporary water and air lines; Material hose operator (walls, slabs, floors and decks); Plugging, filling of shee bolt holes; Dry packing of concrete; Railroad maintenance, repair track person and road beds; Streetcar and railroad construction track laborers; Rigging and signaling; Scaler; Slip form raiser; Tar and mortar; Tool crib or tool house laborer; Traffic control by any method; Window cleaner; Wire mesh pulling - all concrete pouring operations

GROUP 2: Asphalt shoveler; Cement dumper (on 1 yd. or larger mixer and handling bulk cement); Cesspool digger and installer; Chucktender; Chute handler, pouring concrete, the handling of the chute from readymix trucks, such as walls, slabs, decks, floors, foundation, footings, curbs, gutters and sidewalks; Concrete curer, impervious membrane and form oiler; Cutting torch operator (demolition); Fine grader, highways and street paving, airport, runways and similar type heavy construction; Gas, oil and/or water pipeline wrapper - pot tender and form person; Guinea chaser; Headerboard person - asphalt; Laborer, packing rod steel and pans; Membrane vapor barrier installer; Power

broom sweeper (small); Riprap stonepaver, placing stone or wet sacked concrete; Roto scraper and tiller; Sandblaster (pot tender); Septic tank digger and installer(lead); Tank scaler and cleaner; Tree climber, faller, chain saw operator, Pittsburgh chipper and similar type brush shredder; Underground laborer, including caisson bellower

GROUP 3: Buggymobile person; Concrete cutting torch; Concrete pile cutter; Driller, jackhammer, 2-1/2 ft. drill steel or longer; Dri-pak-it machine; Gas, oil and/or water pipeline wrapper, 6-in. pipe and over, by any method, inside and out; High scaler (including drilling of same); Hydro seeder and similar type; Impact wrench multi-plate; Kettle person, pot person and workers applying asphalt, lay-kold, creosote, lime caustic and similar type materials ("applying" means applying, dipping, brushing or handling of such materials for pipe wrapping and waterproofing); Operator of pneumatic, gas, electric tools, vibrating machine, pavement breaker, air blasting, come-alongs, and similar mechanical tools not separately classified herein; Pipelayer's backup person, coating, grouting, making of joints, sealing, caulking, diapering and including rubber gasket joints, pointing and any and all other services; Rock slinger; Rotary scarifier or multiple head concrete chipping scarifier; Steel headerboard and guideline setter; Tamper, Barko, Wacker and similar type; Trenching machine, hand-propelled

GROUP 4: Asphalt raker, lute person, ironer, asphalt dump person, and asphalt spreader boxes (all types); Concrete core cutter (walls, floors or ceilings), grinder or sander; Concrete saw person, cutting walls or flat work, scoring old or new concrete; Cribber, shorer, lagging, sheeting and trench bracing, hand-guided lagging hammer; Head rock slinger; Laborer, asphalt- rubber distributor boot person; Laser beam in connection with laborers' work; Oversize concrete vibrator operator, 70 lbs. and over; Pipelayer performing all services in the laying and installation of pipe from the point of receiving pipe in the ditch until completion of operation, including any and all forms of tubular material, whether pipe, metallic or non-metallic, conduit and any other stationary type of tubular device used for the conveying of any substance or element, whether water, sewage, solid gas, air, or other product whatsoever and without regard to the nature of material from which the tubular material is fabricated; No-joint pipe and stripping of same; Prefabricated manhole installer; Sandblaster (nozzle person), water blasting, Porta Shot-Blast

GROUP 5: Blaster powder, all work of loading holes, placing and blasting of all powder and explosives of whatever type, regardless of method used for such loading and placing; Driller: All power drills, excluding jackhammer, whether core, diamond, wagon, track, multiple unit, and any and all other types of mechanical drills without regard to the form of motive power; Toxic waste removal

TUNNEL LABORER CLASSIFICATIONS

GROUP 1: Batch plant laborer; Changehouse person; Dump person; Dump person (outside); Swamper (brake person and switch person on tunnel work); Tunnel materials handling person; Nipper; Pot tender, using mastic or other materials (for example, but not by way of limitation, shotcrete, etc.)

GROUP 2: Chucktender, cabledtender; Loading and unloading agitator cars; Vibrator person, jack hammer, pneumatic tools (except driller); Bull gang mucker, track person; Concrete crew, including rodder and spreader

GROUP 3: Blaster, driller, powder person; Chemical grout jet person; Cherry picker person; Grout gun person; Grout mixer person; Grout pump person; Jackleg miner; Jumbo person; Kemper and other pneumatic concrete placer operator; Miner, tunnel (hand or machine); Nozzle person; Operating of troweling and/or grouting machines; Powder person (primer house); Primer person; Sandblaster; Shotcrete person; Steel form raiser and setter; Timber person, retimber person, wood or steel; Tunnel Concrete finisher

GROUP 4: Diamond driller; Sandblaster; Shaft and raise work

LAB01184-004 07/01/2022

	Rates	Fringes
Brick Tender.....	\$ 37.32	21.45

LAB01414-001 08/03/2022

	Rates	Fringes
LABORER		
PLASTER CLEAN-UP LABORER....	\$ 38.92	23.32
PLASTER TENDER.....	\$ 41.47	23.32

Work on a swing stage scaffold: \$1.00 per hour additional.

PAIN0036-001 07/01/2023

	Rates	Fringes
Painters: (Including Lead Abatement)		
(1) Repaint (excludes San Diego County).....	\$ 29.59	17.12
(2) All Other Work.....	\$ 38.52	18.64

REPAINT of any previously painted structure. Exceptions: work involving the aerospace industry, breweries, commercial recreational facilities, hotels which operate commercial establishments as part of hotel service, and sports facilities.

PAIN0036-008 09/01/2022

	Rates	Fringes
DRYWALL FINISHER/TAPER.....	\$ 46.28	23.52

PAIN0036-015 01/01/2020

	Rates	Fringes
GLAZIER.....	\$ 43.45	23.39

FOOTNOTE: Additional \$1.25 per hour for work in a condor, from the third (3rd) floor and up Additional \$1.25 per

hour for work on the outside of the building from a swing stage or any suspended contrivance, from the ground up

PLAS0200-009 08/03/2022

	Rates	Fringes
PLASTERER.....	\$ 47.37	19.64

PLAS0500-002 07/01/2020

	Rates	Fringes
CEMENT MASON/CONCRETE FINISHER...	\$ 38.50	25.91

* PLUM0016-001 09/01/2023

	Rates	Fringes
PLUMBER/PIPEFITTER		
Work ONLY on new additions and remodeling of bars, restaurant, stores and commercial buildings not to exceed 5,000 sq. ft. of floor space.....	\$ 53.51	25.28
Work ONLY on strip malls, light commercial, tenant improvement and remodel work.....	\$ 42.49	23.86
All other work except work on new additions and remodeling of bars, restaurant, stores and commercial buildings not to exceed 5,000 sq. ft. of floor space and work on strip malls, light commercial, tenant improvement and remodel work.....	\$ 57.18	26.51

PLUM0345-001 09/01/2023

	Rates	Fringes
PLUMBER		
Landscape/Irrigation Fitter..	\$ 40.20	25.90
Sewer & Storm Drain Work....	\$ 44.29	23.28

ROOF0036-002 08/13/2023

	Rates	Fringes
ROOFER.....	\$ 46.02	20.05

FOOTNOTE: Pitch premium: Work on which employees are exposed to pitch fumes or required to handle pitch, pitch base or pitch impregnated products, or any material containing coal tar pitch, the entire roofing crew shall receive \$1.75 per hour ""pitch premium"" pay.

SFCA0669-002 01/01/2024

	Rates	Fringes
SPRINKLER FITTER.....	\$ 45.31	27.91

SHEE0105-003 01/01/2024

LOS ANGELES (South of a straight line drawn between Gorman and Big Pines)and Catalina Island, INYO, KERN (Northeast part, East of Hwy 395), MONO ORANGE, RIVERSIDE, AND SAN BERNARDINO COUNTIES

	Rates	Fringes
SHEET METAL WORKER		
(1) Commercial - New Construction and Remodel work.....	\$ 56.95	30.04
(2) Industrial work including air pollution control systems, noise abatement, hand rails, guard rails, excluding aritechtrual sheet metal work, excluding A-C, heating, ventilating systems for human comfort...	\$ 56.95	30.04

TEAM0011-002 07/01/2023

	Rates	Fringes
TRUCK DRIVER		
GROUP 1.....	\$ 38.19	33.69
GROUP 2.....	\$ 38.34	33.69
GROUP 3.....	\$ 38.47	33.69
GROUP 4.....	\$ 38.66	33.69
GROUP 5.....	\$ 38.69	33.69
GROUP 6.....	\$ 38.72	33.69
GROUP 7.....	\$ 38.97	33.69
GROUP 8.....	\$ 39.22	33.69
GROUP 9.....	\$ 39.42	33.69
GROUP 10.....	\$ 39.72	33.69
GROUP 11.....	\$ 40.22	33.69
GROUP 12.....	\$ 40.65	33.69

WORK ON ALL MILITARY BASES:
PREMIUM PAY: \$3.00 per hour additional.
[29 palms Marine Base, Camp Roberts, China Lake, Edwards AFB, El Centro Naval Facility, Fort Irwin, Marine Corps Logistics Base at Nebo & Yermo, Mountain Warfare Training Center, Bridgeport, Point Arguello, Point Conception, Vandenberg AFB]

TRUCK DRIVERS CLASSIFICATIONS

GROUP 1: Truck driver

GROUP 2: Driver of vehicle or combination of vehicles - 2 axles; Traffic control pilot car excluding moving heavy equipment permit load; Truck mounted broom

GROUP 3: Driver of vehicle or combination of vehicles - 3

axles; Boot person; Cement mason distribution truck; Fuel truck driver; Water truck - 2 axle; Dump truck, less than 16 yds. water level; Erosion control driver

GROUP 4: Driver of transit mix truck, under 3 yds.; Dumpcrete truck, less than 6-1/2 yds. water level

GROUP 5: Water truck, 3 or more axles; Truck greaser and tire person (\$0.50 additional for tire person); Pipeline and utility working truck driver, including winch truck and plastic fusion, limited to pipeline and utility work; Slurry truck driver

GROUP 6: Transit mix truck, 3 yds. or more; Dumpcrete truck, 6-1/2 yds. water level and over; Vehicle or combination of vehicles - 4 or more axles; Oil spreader truck; Dump truck, 16 yds. to 25 yds. water level

GROUP 7: A Frame, Swedish crane or similar; Forklift driver; Ross carrier driver

GROUP 8: Dump truck, 25 yds. to 49 yds. water level; Truck repair person; Water pull - single engine; Welder

GROUP 9: Truck repair person/welder; Low bed driver, 9 axles or over

GROUP 10: Dump truck - 50 yds. or more water level; Water pull - single engine with attachment

GROUP 11: Water pull - twin engine; Water pull - twin engine with attachments; Winch truck driver - \$1.25 additional when operating winch or similar special attachments

GROUP 12: Boom Truck 17K and above

WELDERS - Receive rate prescribed for craft performing operation to which welding is incidental.

=====
Note: Executive Order (EO) 13706, Establishing Paid Sick Leave for Federal Contractors applies to all contracts subject to the Davis-Bacon Act for which the contract is awarded (and any solicitation was issued) on or after January 1, 2017. If this contract is covered by the EO, the contractor must provide employees with 1 hour of paid sick leave for every 30 hours they work, up to 56 hours of paid sick leave each year. Employees must be permitted to use paid sick leave for their own illness, injury or other health-related needs, including preventive care; to assist a family member (or person who is like family to the employee) who is ill, injured, or has other health-related needs, including preventive care; or for reasons resulting from, or to assist a family member (or person who is like family to the employee) who is a victim of, domestic violence, sexual assault, or stalking. Additional information on contractor requirements and worker protections under the EO is available at <https://www.dol.gov/agencies/whd/government-contracts>.

Unlisted classifications needed for work not included within the scope of the classifications listed may be added after award only as provided in the labor standards contract clauses

(29CFR 5.5 (a) (1) (iii)).

The body of each wage determination lists the classification and wage rates that have been found to be prevailing for the cited type(s) of construction in the area covered by the wage determination. The classifications are listed in alphabetical order of ""identifiers"" that indicate whether the particular rate is a union rate (current union negotiated rate for local), a survey rate (weighted average rate) or a union average rate (weighted union average rate).

Union Rate Identifiers

A four letter classification abbreviation identifier enclosed in dotted lines beginning with characters other than ""SU"" or ""UAVG"" denotes that the union classification and rate were prevailing for that classification in the survey. Example: PLUM0198-005 07/01/2014. PLUM is an abbreviation identifier of the union which prevailed in the survey for this classification, which in this example would be Plumbers. 0198 indicates the local union number or district council number where applicable, i.e., Plumbers Local 0198. The next number, 005 in the example, is an internal number used in processing the wage determination. 07/01/2014 is the effective date of the most current negotiated rate, which in this example is July 1, 2014.

Union prevailing wage rates are updated to reflect all rate changes in the collective bargaining agreement (CBA) governing this classification and rate.

Survey Rate Identifiers

Classifications listed under the ""SU"" identifier indicate that no one rate prevailed for this classification in the survey and the published rate is derived by computing a weighted average rate based on all the rates reported in the survey for that classification. As this weighted average rate includes all rates reported in the survey, it may include both union and non-union rates. Example: SULA2012-007 5/13/2014. SU indicates the rates are survey rates based on a weighted average calculation of rates and are not majority rates. LA indicates the State of Louisiana. 2012 is the year of survey on which these classifications and rates are based. The next number, 007 in the example, is an internal number used in producing the wage determination. 5/13/2014 indicates the survey completion date for the classifications and rates under that identifier.

Survey wage rates are not updated and remain in effect until a new survey is conducted.

Union Average Rate Identifiers

Classification(s) listed under the UAVG identifier indicate that no single majority rate prevailed for those classifications; however, 100% of the data reported for the classifications was union data. EXAMPLE: UAVG-OH-0010 08/29/2014. UAVG indicates that the rate is a weighted union average rate. OH indicates the state. The next number, 0010 in the example, is an internal number used in producing the wage determination. 08/29/2014 indicates the survey completion date

for the classifications and rates under that identifier.

A UAVG rate will be updated once a year, usually in January of each year, to reflect a weighted average of the current negotiated/CBA rate of the union locals from which the rate is based.

WAGE DETERMINATION APPEALS PROCESS

1.) Has there been an initial decision in the matter? This can be:

- * an existing published wage determination
- * a survey underlying a wage determination
- * a Wage and Hour Division letter setting forth a position on a wage determination matter
- * a conformance (additional classification and rate) ruling

On survey related matters, initial contact, including requests for summaries of surveys, should be with the Wage and Hour National Office because National Office has responsibility for the Davis-Bacon survey program. If the response from this initial contact is not satisfactory, then the process described in 2.) and 3.) should be followed.

With regard to any other matter not yet ripe for the formal process described here, initial contact should be with the Branch of Construction Wage Determinations. Write to:

Branch of Construction Wage Determinations
Wage and Hour Division
U.S. Department of Labor
200 Constitution Avenue, N.W.
Washington, DC 20210

2.) If the answer to the question in 1.) is yes, then an interested party (those affected by the action) can request review and reconsideration from the Wage and Hour Administrator (See 29 CFR Part 1.8 and 29 CFR Part 7). Write to:

Wage and Hour Administrator
U.S. Department of Labor
200 Constitution Avenue, N.W.
Washington, DC 20210

The request should be accompanied by a full statement of the interested party's position and by any information (wage payment data, project description, area practice material, etc.) that the requestor considers relevant to the issue.

3.) If the decision of the Administrator is not favorable, an interested party may appeal directly to the Administrative Review Board (formerly the Wage Appeals Board). Write to:

Administrative Review Board
U.S. Department of Labor
200 Constitution Avenue, N.W.
Washington, DC 20210

4.) All decisions by the Administrative Review Board are final.

=====

END OF GENERAL DECISION"

**CITY OF BEAUMONT
PUBLIC WORKS AGREEMENT**

EXHIBIT "B"

CONTRACTOR'S Bid



BID FORM

NAME OF BIDDER: CT&T Concrete Paving Inc.

The undersigned, hereby declare that we have carefully examined the location of the proposed Work, and have read and examined the Contract Documents, including all plans, specifications, and all addenda, if any, for the following Project:

CITYWIDE SIDEWALK IMPROVEMENTS CIP R-24

We hereby propose to furnish all labor, materials, equipment, tools, transportation, and services, and to discharge all duties and obligations necessary and required to perform and complete the Project for the following TOTAL BID PRICE:

BASE BID	BASE BID PRICE (IN WRITTEN FORM)	BID PRICE (IN NUMBERS)
BASE BID (Massachusetts)	Four Hundred Twenty-Eight Thousand, Three Hundred Fifty-Five Dollars	428,355. ⁰⁰
ADDITIVE A (Magnolia)	Four Hundred Thirty Thousand, Five Hundred Dollars	430,500. ⁰⁰
ADDITIVE B (Elm)	Four Hundred Eighteen Thousand, Four Hundred Forty-Five Dollars	418,445. ⁰⁰
ADDITIVE C (Chestnut)	Four Hundred Forty-Two Thousand, One Hundred Twenty-Five Dollars	442,125. ⁰⁰
ADDITIVE D (N. California)	Five Hundred Forty-One Thousand, Thirty-Five Dollars	541,035. ⁰⁰
ADDITIVE E (Wellwood)	Six Hundred Forty-Eight Thousand, Six Hundred & Twenty Dollars	648,620. ⁰⁰



<p>ADDITIVE F (Edgar)</p>	<p>Eight Hundred & five thousand & one hundred eighty five dollars & Zero cents</p>	<p>805,185.⁰⁰</p>
<p>ADDITIVE G (Euclid)</p>	<p>Eight hundred ninety thousand & nine hundred seventy five dollars & Zero cents</p>	<p>890,975.⁰⁰</p>
<p>TOTAL BID PRICE</p>	<p>four Million Six hundred & five thousand & two hundred five dollars & zero cents</p>	<p>4,605,240.⁰⁰</p>

In case of discrepancy between the written price and the numerical price, the written price shall prevail.



**BASE BID
BID SCHEDULE
CITYWIDE SIDEWALK IMPROVEMENTS CIP R-24**

MASSACHUSETTS AVENUE

ITEM NO.	DESCRIPTION OF ITEMS	EST. QUANTITY/ UNIT		UNIT PRICE (FIGURES)	TOTAL COST (FIGURES)
1	TEMPORARY CONSTRUCTION SIGN	2	EA	3,150. ⁰⁰	6,300. ⁰⁰
2	INSTALL NEW SIDEWALK	1410	LF	84	118,440
3	PCC PAVEMENT (DRIVEWAY APPROACH)	42	EA	3,650	153,300
4	REMOVE TREE (LARGE)	3	EA	1,705	5,115
5	REMOVE TREE (SMALL)	2	EA	825	1,650
6	REMOVE CONCRETE (EXISTING DRIVEWAY APPROACH)	38	EA	1,425	54,150
7	REMOVE CONCRETE (EXISTING SIDEWALK)	40	LF	30	1,200.
8	REMOVE CONCRETE (EXISTING CURB & GUTTER)	0	LF	—	—
9	RELOCATE MAILBOX	29	EA	1,200	34,800
10	CURB INLET CATCH BASIN	0	EA	—	—
11	CURB OUTLET DRAIN	0	EA	—	—
12	MINOR CONCRETE (CURB RAMP CASE A)	0	EA	—	—
13	MINOR CONCRETE (CURB RAMP CASE B)	0	EA	—	—
14	MINOR CONCRETE (CURB RAMP CASE C)	2	EA	9,500	19,000
15	CURB RAMP DETECTABLE WARNING SURFACE	0	EA	—	—
16	INSTALL NEW CURB & GUTTER	120	LF	70	8,400
17	RELOCATE CANDLESTICK LIGHT POLE	1	EA	11,000	11,000
19	ADJUST WATER SERVICE METER BOX ELEVATION	20	EA	750	15,000
PROJECT BASE BID SUBTOTAL:					428,355.⁰⁰



ADDITIVE BID A
BID SCHEDULE
CITYWIDE SIDEWALK IMPROVEMENTS CIP R-24

MAGNOLIA AVENUE

ITEM NO.	DESCRIPTION OF ITEMS	EST. QUANTITY/ UNIT	UNIT PRICE (FIGURES)	TOTAL COST (FIGURES)
1	TEMPORARY CONSTRUCTION SIGN	2 EA	3,150	6,300
2	INSTALL NEW SIDEWALK	1120 LF	87	97,440
3	PCC PAVEMENT (DRIVEWAY APPROACH)	29 EA	5,100	147,900
4	REMOVE TREE (LARGE)	0 EA	—	—
5	REMOVE TREE (SMALL)	0 EA	—	—
6	REMOVE CONCRETE (EXISTING DRIVEWAY APPROACH)	24 EA	1,950	46,800
7	REMOVE CONCRETE (EXISTING SIDEWALK)	80 LF	38	3,040
8	REMOVE CONCRETE (EXISTING CURB & GUTTER)	50 LF	48	2,400
9	RELOCATE MAILBOX	15 EA	1,200	18,000
10	CURB INLET CATCH BASIN	0 EA	—	—
11	CURB OUTLET DRAIN	0 EA	—	—
12	MINOR CONCRETE (CURB RAMP CASE A)	1 EA	9,500	9,500
13	MINOR CONCRETE (CURB RAMP CASE B)	1 EA	10,350	10,350
14	MINOR CONCRETE (CURB RAMP CASE C)	4 EA	10,750	43,000
15	CURB RAMP DETECTABLE WARNING SURFACE	0 EA	—	—
16	INSTALL NEW CURB & GUTTER	640 LF	68	
17	RELOCATE CANDLESTICK LIGHT POLE	0 EA	—	—
19	ADJUST WATER SERVICE METER BOX ELEVATION	3 EA	750	2,250
ADDITIVE A SUBTOTAL:				430,500.



ADDITIVE BID B
BID SCHEDULE
CITYWIDE SIDEWALK IMPROVEMENTS CIP R-24

ELM AVENUE

ITEM NO.	DESCRIPTION OF ITEMS	EST. QUANTITY/ UNIT		UNIT PRICE (FIGURES)	TOTAL COST (FIGURES)
1	TEMPORARY CONSTRUCTION SIGN	2	EA	2,500	5,000
2	INSTALL NEW SIDEWALK	1500	LF	85	127,500
3	PCC PAVEMENT (DRIVEWAY APPROACH)	20	EA	4,950	99,000
4	REMOVE TREE (LARGE)	8	EA	1,705	13,640
5	REMOVE TREE (SMALL)	0	EA	—	—
6	REMOVE CONCRETE (EXISTING DRIVEWAY APPROACH)	16	EA	1500	24,000
7	REMOVE CONCRETE (EXISTING SIDEWALK)	30	LF	40	1,200
8	REMOVE CONCRETE (EXISTING CURB & GUTTER)	235	LF	65	15,275
9	RELOCATE MAILBOX	16	EA	1,200	19,200
10	CURB INLET CATCH BASIN	2	EA	2,000	4,000
11	CURB OUTLET DRAIN	0	EA	—	—
12	MINOR CONCRETE (CURB RAMP CASE A)	3	EA	9,450	28,350
13	MINOR CONCRETE (CURB RAMP CASE B)	2	EA	9,850	19,700
14	MINOR CONCRETE (CURB RAMP CASE C)	1	EA	10,250	10,250
15	CURB RAMP DETECTABLE WARNING SURFACE	1	EA	10,650	10,650
16	INSTALL NEW CURB & GUTTER	265	LF	62	16,430
17	RELOCATE CANDLESTICK LIGHT POLE	2	EA	11,000	22,000
19	ADJUST WATER SERVICE METER BOX ELEVATION	3	EA	750	2,250
ADDITIVE B SUBTOTAL:					418,445.00



ADDITIVE BID C
BID SCHEDULE
CITYWIDE SIDEWALK IMPROVEMENTS CIP R-24

CHESTNUT ANENUE

ITEM NO.	DESCRIPTION OF ITEMS	EST. QUANTITY/ UNIT		UNIT PRICE (FIGURES)	TOTAL COST (FIGURES)
1	TEMPORARY CONSTRUCTION SIGN	2	EA	2,500	5000
2	INSTALL NEW SIDEWALK	1530	LF	80	122 400
3	PCC PAVEMENT (DRIVEWAY APPROACH)	31	EA	4925	152675
4	REMOVE TREE (LARGE)	8	EA	1705	13 640
5	REMOVE TREE (SMALL)	2	EA	825	1650
6	REMOVE CONCRETE (EXISTING DRIVEWAY APPROACH)	31	EA	1450	44950
7	REMOVE CONCRETE (EXISTING SIDEWALK)	80	LF	40	3200.
8	REMOVE CONCRETE (EXISTING CURB & GUTTER)	10	LF	65	650
9	RELOCATE MAILBOX	30	EA	1200	36,000
10	CURB INLET CATCH BASIN	0	EA	—	—
11	CURB OUTLET DRAIN	0	EA	—	—
12	MINOR CONCRETE (CURB RAMP CASE A)	2	EA	9850	19,700
13	MINOR CONCRETE (CURB RAMP CASE B)	1	EA	10250	10250
14	MINOR CONCRETE (CURB RAMP CASE C)	0	EA	—	—
15	CURB RAMP DETECTABLE WARNING SURFACE	1	EA	1250	1250
16	INSTALL NEW CURB & GUTTER	70	LF	68	4760
17	RELOCATE CANDLESTICK LIGHT POLE	1	EA	11000	11000
19	ADJUST WATER SERVICE METER BOX ELEVATION	20	EA	750	15000
ADDITIVE C SUBTOTAL:					442,125



ADDITIVE BID D
BID SCHEDULE
CITYWIDE SIDEWALK IMPROVEMENTS CIP R-24

N. CALIFORNIA AVENUE

ITEM NO.	DESCRIPTION OF ITEMS	EST. QUANTITY/ UNIT		UNIT PRICE (FIGURES)	TOTAL COST (FIGURES)
1	TEMPORARY CONSTRUCTION SIGN	2	EA	2500	5000
2	INSTALL NEW SIDEWALK	1350	LF	84	113400
3	PCC PAVEMENT (DRIVEWAY APPROACH)	23	EA	5000	115000
4	REMOVE TREE (LARGE)	7	EA	1705	11935
5	REMOVE TREE (SMALL)	6	EA	825	4950
6	REMOVE CONCRETE (EXISTING DRIVEWAY APPROACH)	20	EA	2200	44000
7	REMOVE CONCRETE (EXISTING SIDEWALK)	120	LF	55	6600
8	REMOVE CONCRETE (EXISTING CURB & GUTTER)	0	LF	—	—
9	RELOCATE MAILBOX	20	EA	1200	24000
10	CURB INLET CATCH BASIN	0	EA	—	—
11	CURB OUTLET DRAIN	0	EA	—	—
12	MINOR CONCRETE (CURB RAMP CASE A)	3	EA	9400	28200
13	MINOR CONCRETE (CURB RAMP CASE B)	0	EA	—	—
14	MINOR CONCRETE (CURB RAMP CASE C)	12	EA	12500	150000
15	CURB RAMP DETECTABLE WARNING SURFACE	1	EA	1650	1650
16	INSTALL NEW CURB & GUTTER	350	LF	68	23800
17	RELOCATE CANDLESTICK LIGHT POLE	1	EA	11000	11000
19	ADJUST WATER SERVICE METER BOX ELEVATION	2	EA	750	1500
ADDITIVE D SUBTOTAL:					541,035



ADDITIVE BID E
BID SCHEDULE
CITYWIDE SIDEWALK IMPROVEMENTS CIP R-24

WELLWOOD AVENUE

ITEM NO.	DESCRIPTION OF ITEMS	EST. QUANTITY/ UNIT		UNIT PRICE (FIGURES)	TOTAL COST (FIGURES)
1	TEMPORARY CONSTRUCTION SIGN	2	EA	5,000.00	10,000.00
2	INSTALL NEW SIDEWALK	1400	LF	78.50	109,900.00
3	PCC PAVEMENT (DRIVEWAY APPROACH)	42	EA	5,075.00	213,150.00
4	REMOVE TREE (LARGE)	4	EA	1705.00	6820.00
5	REMOVE TREE (SMALL)	2	EA	825.00	1650.00
6	REMOVE CONCRETE (EXISTING DRIVEWAY APPROACH)	35	EA	1,650.00	57,750.00
7	REMOVE CONCRETE (EXISTING SIDEWALK)	50	LF	40.00	2,000.00
8	REMOVE CONCRETE (EXISTING CURB & GUTTER)	0	LF	—	—
9	RELOCATE MAILBOX	17	EA	1,200.00	20,400.00
10	CURB INLET CATCH BASIN	1	EA	28,500.00	28,500.00
11	CURB OUTLET DRAIN	1	EA	10,850.00	10,850.00
12	MINOR CONCRETE (CURB RAMP CASE A)	5	EA	9,450.00	47,250.00
13	MINOR CONCRETE (CURB RAMP CASE B)	0	EA	—	—
14	MINOR CONCRETE (CURB RAMP CASE C)	10	EA	10,250.00	102,500.00
15	CURB RAMP DETECTABLE WARNING SURFACE	0	EA	—	—
16	INSTALL NEW CURB & GUTTER	200	LF	68	13,600.00
17	RELOCATE CANDLESTICK LIGHT POLE	2	EA	11,000.00	22,000.00
19	ADJUST WATER SERVICE METER BOX ELEVATION	3	EA	750.00	2,250.00
ADDITIVE E SUBTOTAL:					648,620.00



ADDITIVE BID F
BID SCHEDULE
CITYWIDE SIDEWALK IMPROVEMENTS CIP R-24

EDGAR AVENUE

ITEM NO.	DESCRIPTION OF ITEMS	EST. QUANTITY/ UNIT		UNIT PRICE (FIGURES)	TOTAL COST (FIGURES)
1	TEMPORARY CONSTRUCTION SIGN	2	EA	5000	10000
2	INSTALL NEW SIDEWALK	2500	LF	74	185,000
3	PCC PAVEMENT (DRIVEWAY APPROACH)	53	EA	4935	261,555
4	REMOVE TREE (LARGE)	6	EA	1705	10,230
5	REMOVE TREE (SMALL)	8	EA	825	6600
6	REMOVE CONCRETE (EXISTING DRIVEWAY APPROACH)	35	EA	1300	45500
7	REMOVE CONCRETE (EXISTING SIDEWALK)	60	LF	40	2400
8	REMOVE CONCRETE (EXISTING CURB & GUTTER)	0	LF	—	—
9	RELOCATE MAILBOX	22	EA	1200	
10	CURB INLET CATCH BASIN	0	EA	—	—
11	CURB OUTLET DRAIN	0	EA	—	—
12	MINOR CONCRETE (CURB RAMP CASE A)	7	EA	9250	64750
13	MINOR CONCRETE (CURB RAMP CASE B)	6	EA	9450	56700
14	MINOR CONCRETE (CURB RAMP CASE C)	8	EA	9850	78800
15	CURB RAMP DETECTABLE WARNING SURFACE	0	EA	—	—
16	INSTALL NEW CURB & GUTTER	0	LF	—	—
17	RELOCATE CANDLESTICK LIGHT POLE	5	EA	11000	55000
19	ADJUST WATER SERVICE METER BOX ELEVATION	3	EA	750	2250
ADDITIVE F SUBTOTAL:					805,185. ⁰⁰



ADDITIVE BID G
BID SCHEDULE
CITYWIDE SIDEWALK IMPROVEMENTS CIP R-24

EUCLID AVENUE

ITEM NO.	DESCRIPTION OF ITEMS	EST. QUANTITY/ UNIT		UNIT PRICE (FIGURES)	TOTAL COST (FIGURES)
1	TEMPORARY CONSTRUCTION SIGN	2	EA	5000	10000
2	INSTALL NEW SIDEWALK	3120	LF	85	265200
3	PCC PAVEMENT (DRIVEWAY APPROACH)	53	EA	5295	280,635
4	REMOVE TREE (LARGE)	6	EA	1705	10230
5	REMOVE TREE (SMALL)	6	EA	825	4950
6	REMOVE CONCRETE (EXISTING DRIVEWAY APPROACH)	43	EA	1650	70 950
7	REMOVE CONCRETE (EXISTING SIDEWALK)	350	LF	40	14000
8	REMOVE CONCRETE (EXISTING CURB & GUTTER)	0	LF	—	—
9	RELOCATE MAILBOX	23	EA	1200	27600
10	CURB INLET CATCH BASIN	0	EA	—	—
11	CURB OUTLET DRAIN	0	EA	—	—
12	MINOR CONCRETE (CURB RAMP CASE A)	4	EA	9250	37000
13	MINOR CONCRETE (CURB RAMP CASE B)	6	EA	9350	56100
14	MINOR CONCRETE (CURB RAMP CASE C)	6	EA	9750	58500
15	CURB RAMP DETECTABLE WARNING SURFACE	1	EA	1200	1200
16	INSTALL NEW CURB & GUTTER	80	LF	67	5360
17	RELOCATE CANDLESTICK LIGHT POLE	4	EA	11000	44000
19	ADJUST WATER SERVICE METER BOX ELEVATION	7	EA	750	5250
ADDITIVE G SUBTOTAL:					890,975.00



In case of discrepancy between the unit price and the item cost set forth for a unit basis item, the unit price shall prevail and, shall be utilized as the basis for determining the lowest responsive, responsible bidder. However, if the amount set forth as a unit price is ambiguous, unintelligible or uncertain for any cause, or is omitted, or is the same amount as the entry in the "Item Cost" column, then the amount set forth in the "Item Cost" column for the item shall prevail and shall be divided by the estimated quantity for the item and the price thus obtained shall be the unit price. Final payment shall be determined by the Engineer from measured quantities of work performed based upon the unit price.

In case of discrepancy between the written price and the numerical price, the written price shall prevail.



BID CERTIFICATION

Bidder certifies that it is licensed in accordance with the law providing for the registration of Contractors,

License No. 875627

Expiration Date 04/30/2026

Class of license A, C8, C12

If the bidder is a joint venture, each member of the joint venture must include the above information.

The undersigned acknowledges receipt, understanding and full consideration of the following addenda to the Contract Documents:

1. Addenda No. 1 thru 2
2. Attached is the required bid security in the amount of not less than 10% of the Total Bid Price.
3. Attached is the fully executed Non-Collusion Affidavit form.
4. Attached is the completed Designation of Subcontractors form.
5. Attached is the completed Bidder Information Form.
6. Attached is the completed Contractor's Certificate Regarding Workers' Compensation form.

Bidder acknowledges and understands that, pursuant to Public Contract Code Section 20676, sellers of "mined material" must be on an approved list of sellers published pursuant to Public Resources Code Section 2717(b) in order to supply mined material for this Contract.

I hereby certify under penalty of perjury under the laws of the State of California, that all of the information submitted in connection with this Bid and all of the representations made herein are true and correct.

Name of Bidder CT&T Concrete Paving Inc.

Signature 

Name and Title Jose Carvajal, President

Dated 04/03/2024



CONTRACTOR'S CERTIFICATE REGARDING WORKERS' COMPENSATION

CITYWIDE SIDEWALK IMPROVEMENTS CIP R-24

I am aware of the provisions of Section 3700 of the Labor Code which require every employer to be insured against liability for workers' compensation or to undertake self-insurance in accordance with the provisions of that code, and I will comply with such provisions before commencing the performance of the work of this Contract.

Name of Bidder CT&T Concrete Paving Inc.

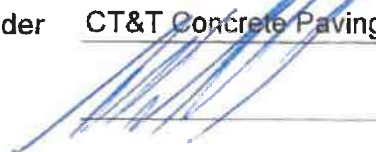
Signature 

Name and Title Jose Carvajal, President

Dated 04/3/2024



BID BOND

CITYWIDE SIDEWALK IMPROVEMENTS CIP R-24

The makers of this bond are,

CT&T Concrete Paving, Inc.

_____ as Principal, and

Contractors Bonding and Insurance Company

_____, as Surety

and are held and firmly bound unto the City of Beaumont, hereinafter called the City, in the penal sum of TEN PERCENT (10%) OF THE TOTAL BID PRICE of the Principal submitted to CITY for the work described below, for the payment of which sum in lawful money of the United States, well and truly to be made, we bind ourselves, our heirs, executors, administrators, successors and assigns, jointly and severally, firmly by these presents.

THE CONDITION OF THIS OBLIGATION IS SUCH that whereas the Principal has submitted the accompanying bid dated April 3, 20 24, for _____

CITYWIDE SIDEWALK IMPROVEMENTS CIP R-24

If the Principal does not withdraw its bid within the time specified in the Contract Documents; and if the Principal is awarded the Contract and provides all documents to the City as required by the Contract Documents; then this obligation shall be null and void. Otherwise, this bond will remain in full force and effect.

Surety, for value received, hereby stipulates and agrees that no change, extension of time, alteration or addition to the terms of the Contract Documents shall in affect its obligation under this bond, and Surety does hereby waive notice of any such changes.

In the event a lawsuit is brought upon this bond by the City and judgment is recovered, the Surety shall pay all litigation expenses incurred by the City in such suit, including reasonable attorneys' fees, court costs, expert witness fees and expenses.



IN WITNESS WHEREOF, the above-bound parties have executed this instrument under their several seals this 1st day of April, 2024, the name and corporate seal of each corporation.

(Corporate Seal)

CT&T Concrete Paving, Inc.

Principal

By

President

Title

(Corporate Seal)

Contractors Bonding and Insurance Company

Surety

By

Emilie George

Emilie George

Attorney-in-Fact

(Attach Attorney-in-Fact Certificate)

Attorney-in-Fact

Title

CALIFORNIA ALL- PURPOSE CERTIFICATE OF ACKNOWLEDGMENT

A notary public or other officer completing this certificate verifies only the identity of the individual who signed the document to which this certificate is attached, and not the truthfulness, accuracy, or validity of that document.

State of California }

County of Los Angeles }

On April 2nd, 2024 before me, Daniel A. Butler, A Notary Public,
(Here insert name and title of the officer)

personally appeared Jose Carvajal,
who proved to me on the basis of satisfactory evidence to be the person(s) whose name(s) (s) are subscribed to the within instrument and acknowledged to me that he/she/they executed the same in his/her/their authorized capacity(ies), and that by his/her/their signature(s) on the instrument the person(s), or the entity upon behalf of which the person(s) acted, executed the instrument.

I certify under PENALTY OF PERJURY under the laws of the State of California that the foregoing paragraph is true and correct.

WITNESS my hand and official seal.

Daniel A. Butler
Notary Public Signature

(Notary Public Seal)

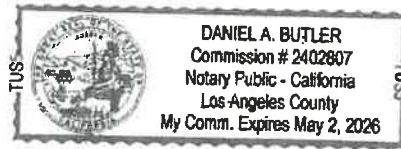

ADDITIONAL OPTIONAL INFORMATION

DESCRIPTION OF THE ATTACHED DOCUMENT

(Title or description of attached document)

(Title or description of attached document continued)

Number of Pages _____ Document Date _____

CAPACITY CLAIMED BY THE SIGNER

Individual (s)

Corporate Officer

(Title)

Partner(s)

Attorney-in-Fact

Trustee(s)

Other _____

INSTRUCTIONS FOR COMPLETING THIS FORM

- This form complies with current California statutes regarding notary wording and, if needed, should be completed and attached to the document. Acknowledgments from other states may be completed for documents being sent to that state so long as the wording does not require the California notary to violate California notary law.*
- State and County information must be the State and County where the document signer(s) personally appeared before the notary public for acknowledgment.
 - Date of notarization must be the date that the signer(s) personally appeared which must also be the same date the acknowledgment is completed.
 - The notary public must print his or her name as it appears within his or her commission followed by a comma and then your title (notary public).
 - Print the name(s) of document signer(s) who personally appear at the time of notarization.
 - Indicate the correct singular or plural forms by crossing off incorrect forms (i.e. he/she/they, is /are) or circling the correct forms. Failure to correctly indicate this information may lead to rejection of document recording.
 - The notary seal impression must be clear and photographically reproducible. Impression must not cover text or lines. If seal impression smudges, re-seal if a sufficient area permits, otherwise complete a different acknowledgment form.
 - Signature of the notary public must match the signature on file with the office of the county clerk.
 - ❖ Additional information is not required but could help to ensure this acknowledgment is not misused or attached to a different document.
 - ❖ Indicate title or type of attached document, number of pages and date.
 - ❖ Indicate the capacity claimed by the signer. If the claimed capacity is a corporate officer, indicate the title (i.e. CEO, CFO, Secretary).
 - Securely attach this document to the signed document with a staple.



STATE OF CALIFORNIA)
) ss.
CITY OF _____)

On this _____ day of _____, in the year 20____, before me, _____, a Notary Public in and for said state, personally appeared _____, known to me to be the person whose name is subscribed to the within instrument as the Attorney-In-Fact of the (Surety) acknowledged to me that he subscribed the name of the _____ (Surety) thereto and his own name as Attorney-In-Fact.

Notary Public in and for said State

(SEAL)

Commission expires: _____

NOTE: A copy of the Power-of-Attorney to local representatives of the bonding company must be attached hereto.

ARIZONA NOTARY ACKNOWLEDGMENT

State of Arizona

County of Maricopa

}

On this APR 01 2024, before me Danielle Hanson
[Name of Notary Public]

personally appeared Emilie George, whose identity was proven
[Name of Signer]

to me on the basis of satisfactory evidence to be the person who he or she claims to be, and
acknowledged that he or she signed the above/attached document.

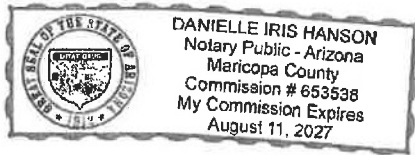

Witness my hand and official seal.

(Seal)
[Affix Seal Here]



Signature of Notary Public

POWER OF ATTORNEY

RLI Insurance Company Contractors Bonding and Insurance Company

9025 N. Lindbergh Dr. Peoria, IL 61615
Phone: 800-645-2402

Know All Men by These Presents:

That this Power of Attorney is not valid or in effect unless attached to the bond which it authorizes executed, but may be detached by the approving officer if desired.

That RLI Insurance Company and/or Contractors Bonding and Insurance Company, each an Illinois corporation, (separately and together, the "Company") do hereby make, constitute and appoint:

Yung T. Mullick, James W. Moilanen, P. Austin Neff, Irene Luong, Emilie George, Danielle Hanson, Christine Woolford, Alexander R. Holsheimer, jointly or severally

in the City of Mission Viejo, State of California its true and lawful Agent(s) and Attorney(s) in Fact, with full power and authority hereby conferred, to sign, execute, acknowledge and deliver for and on its behalf as Surety, in general, any and all bonds and undertakings in an amount not to exceed Twenty Five Million Dollars (\$25,000,000.00) for any single obligation.

The acknowledgment and execution of such bond by the said Attorney in Fact shall be as binding upon the Company as if such bond had been executed and acknowledged by the regularly elected officers of the Company.

RLI Insurance Company and/or Contractors Bonding and Insurance Company, as applicable, have each further certified that the following is a true and exact copy of a Resolution adopted by the Board of Directors of each such corporation, and is now in force, to-wit:

"All bonds, policies, undertakings, Powers of Attorney or other obligations of the corporation shall be executed in the corporate name of the Company by the President, Secretary, any Assistant Secretary, Treasurer, or any Vice President, or by such other officers as the Board of Directors may authorize. The President, any Vice President, Secretary, any Assistant Secretary, or the Treasurer may appoint Attorneys in Fact or Agents who shall have authority to issue bonds, policies or undertakings in the name of the Company. The corporate seal is not necessary for the validity of any bonds, policies, undertakings, Powers of Attorney or other obligations of the corporation. The signature of any such officer and the corporate seal may be printed by facsimile."

IN WITNESS WHEREOF, the RLI Insurance Company and/or Contractors Bonding and Insurance Company, as applicable, have caused these presents to be executed by its respective Vice President with its corporate seal affixed this 15th day of February, 2023.



RLI Insurance Company
Contractors Bonding and Insurance Company

By: B. W. Davis
Barton W. Davis Vice President

State of Illinois }
County of Peoria } SS

CERTIFICATE

On this 15th day of February, 2023, before me, a Notary Public, personally appeared Barton W. Davis, who being by me duly sworn, acknowledged that he signed the above Power of Attorney as the aforesaid officer of the RLI Insurance Company and/or Contractors Bonding and Insurance Company and acknowledged said instrument to be the voluntary act and deed of said corporation.

I, the undersigned officer of RLI Insurance Company and/or Contractors Bonding and Insurance Company, do hereby certify that the attached Power of Attorney is in full force and effect and is irrevocable; and furthermore, that the Resolution of the Company as set forth in the Power of Attorney, is now in force. In testimony whereof, I have hereunto set my hand and the seal of the RLI Insurance Company and/or Contractors Bonding and Insurance Company this 1st day of April, 2024.

By: Catherine D. Geiger
Catherine D. Geiger Notary Public

RLI Insurance Company
Contractors Bonding and Insurance Company

By: Jeffrey D. Dick
Jeffrey D. Dick Corporate Secretary





DESIGNATION OF SUBCONTRACTORS

CITYWIDE SIDEWALK IMPROVEMENTS CIP R-24

In compliance with the Subletting and Subcontracting Fair Practices Act of the Public Contract Code of the State of California, each bidder shall set forth below: (a) the name and the location of the place of business and (b) the portion of the work which will be done by each subcontractor who will perform work or labor or render service to the Contractor in excess of one-half of 1 percent of the prime contractor's total bid or ten thousand dollars (\$10,000), whichever is greater.

Portion of the Work	Subcontractor	Location of Business	% of Work
Electrical	California Professional Engineering	La Puente, CA	19%
Tree Removals	V&A Tree Service	Garden Grove, CA	10%
-		-	



Portion of the Work	Subcontractor	Location of Business	% of Work

Name of Bidder CT&T Concrete Paving Inc.

Signature 

Name and Title Jose Carvajal, President

Dated 04/03/2024

DESIGNATION OF SUBCONTRACTORS



INFORMATION REQUIRED OF BIDDERS

CITYWIDE SIDEWALK IMPROVEMENTS CIP R-24

A. INFORMATION ABOUT BIDDER

[**Indicate not applicable ("N/A") where appropriate.**]

NOTE: Where Bidder is a joint venture, pages shall be duplicated and information provided for all parties to the joint venture.

- 1.0 Name of Bidder: CT&T Concrete Paving Inc.
- 2.0 Type, if Entity: S Corp
- 3.0 Bidder Address: 324 S. Diamond Bar Blvd, PMB 275, Diamond Bar, CA 91765

<u>909-629-8001</u>	<u>909-629-8000</u>
Facsimile Number	Telephone Number

4.0 License Information:

<u>875627</u>	<u>A, C8, C12</u>	<u>04/30/2026</u>
License No.	Class of License	Expiration Date

1000025154
DIR Registration No.

5.0 How many years has Bidder's organization been in business as a Contractor?
22

5.1 How many years has Bidder's organization been in business under its present name? 7

6.0 Under what other or former names has Bidder's organization operated?
CT&T Inc,

7.0 If Bidder's organization is a corporation, answer the following:

INFORMATION REQUIRED OF BIDDERS



- 7.1 Date of Incorporation: 03/05/2006
- 7.2 State of Incorporation: California
- 7.3 President's Name: Jose Carvajal
- 7.4 Vice-President's Name(s): N/A
- 7.5 Secretary's Name: Jose Carvajal
- 7.6 Treasurer's Name: Jackie Carvajal
- 8.0 If an individual or a partnership, answer the following:
- 8.1 Date of Organization: N/A
- 8.2 Name and address of all partners (state whether general or limited partnership):

- 9.0 If other than a corporation or partnership, describe organization and name principals: N/A

- 10.0 List other states in which Bidder's organization is legally qualified to do business.
None

- 11.0 What type of work does the Bidder normally perform with its own forces?
Concrete, Earthwork & Paving - including removal and replacement of sidewalk, curb &
gutters, ADA ramps, drive approaches, and various miscellaneous concrete repairs
- 12.0 Has Bidder ever failed to complete any work awarded to it? If so, note when,

INFORMATION REQUIRED OF BIDDERS



where, and why:

No

13.0 Within the last five years, has any officer or partner of Bidder's organization ever been an officer or partner of another organization when it failed to complete a contract?

If so, attach a separate sheet of explanation:

No

14.0 List Trade References:

Rolhard Inc. - Larry Harden, Acct .manager - 800-393-1642

Robertson's Ready Mix - Edgar Orozco, Sales Rep - 800-560-1150 x6502

15.0 List Bank References (Bank and Branch Address):

Pacific Western Bank - Anaheim Branch

2400 E. Katella Ave, #125, Anaheim, CA 92806

Agent: Wendy Gray, wgray@pacificwesternbank.com

16.0 Name of Bonding Company and Name and Address of Agent:

The Bond Exchange

24800 Chrisanta Ave, St. 160, Mission Viejo, CA

Agent: Yung Mullick (949) 461-7000



B. LIST OF CURRENT PROJECTS (Backlog)

[**Duplicate Page if needed for listing additional current projects.**]

Project	Description of Bidder's Work	Completion Date	Cost of Bidder's Work	Contact Name & Phone
Please see attached				



3.3 List of Current Projects (BACKLOG)

	Project Name	Owner	Contact Person Phone No.	Purpose of Contract	Scheduled Completion	Contract Amount
1	Removal and Replacement of Sidewalks, Curbs, and Gutters No 2019	City of Brea 545 N. Berry Street Brea, CA 92821	Will Wenz (714) 990-7695	Maintenance Project: R/R Sidewalk, Curb & Gutters, and Drive Approaches	Ongoing	\$ 180,000.00
2	Concrete Repair Services Project	City of Chino P.O. Box 667 Chino, CA 91708	Jesse Lopez (909) 334-3266	Maintenance Project: R/R Sidewalk, Curb & Gutters, and Drive Approaches	Ongoing (2023)	\$ 285,280.00
3	On-Call Concrete Repairs	City of Garden Grove 11222 Acacia Pkwy, Garden Grove, CA 92840	Raul Leyva raul@ggcity.org	Maintenance Project: R/R Sidewalk, Curb & Gutters, and Drive Approaches	Ongoing (2023)	\$ 1,300,000.00
4	On-Call Concrete Repairs	City of Corona 400 S Vicentia Ave Corona, CA 92882	Jesse Encino 951 903-9760	Maintenance Project: R/R Sidewalk, Curb & Gutters, and Drive Approaches	Ongoing (2023)	\$ 900,000.00
5	Road Maintenance Services	City of Diamond Bar 21810 Copley Dr. Diamond Bar, CA 91765	Jorge Garcia 909-839-7046	Maintenance Project: R/R Sidewalk, Curb & Gutters, and Drive Approaches	Ongoing	Work Orders per Unit Pricing
6	Master Agreements for Facility Maintenance, Repair, Replacement, and Immediate Response Services	City of Anaheim 400 E Vermont Ave Anaheim, CA	TBD	Maintenance Project: R/R Sidewalk, Curb & Gutters, and Drive Approaches	Ongoing	Work Orders per Unit Pricing
7	Citywide Hardscape Maintenance	City of Paramount 16400 Colorado Ave Paramount, CA 90723	Mario Flores (562) 220-2113	Maintenance Project: R/R Sidewalk, Curb & Gutters, and Drive Approaches	Ongoing	\$ 199,408.00
8	On Call Concrete Repairs	City of Eastvale 12363 Limonite Ave #910 Eastvale, CA 91752	Yurhi Choi 951.703.4471	Maintenance Project: R/R Sidewalk, Curb & Gutters, and Drive Approaches	Ongoing	Work Orders per Unit Pricing
9	CDBG ADA Concrete Ramps Construction SM 2324-7	City of Ontario 303 E B St Ontario, CA 91764	Daniel Leon 909-395-2632	Remove and replace ADA Curb Ramps at various locations	June 2024	\$ 175,000.00
10	TCC Active Transportation Projects C&D	City of Ontario 303 E B St Ontario, CA 91764	Nathan Kuan 909-395-2109	Construction of missing sidewalk segments, handicap ramps, and street lights, bus pads, and shelters	January 2024	\$ 1,540,625.68
11	CIP No. 106, Citywide Sidewalk Repairs & Concrete Construction Project	City of Laguna Hills 24035 El Toro Road, Laguna Hills, CA 92653	Joe Ames, PE (949) 707-2655	R&R of existing sidewalk, curb, & retaining wall	March 2024	\$ 607,850.00
12	Safe Routes to School Gap Closure	City of Fontana 8353 Sierra Ave. Fontana, CA 92335	Estephany Monroy (909) 350-6642	Removing and installing sidewalks and ADA ramps, curb and gutter, street signing and striping. Installing high-visibility crosswalks and street lighting.	June 2024	\$ 3,615,087.50
13	FY 23-24 Americans with Disabilities Act (ADA) Curb Ramp Installation - (CDBG)	City of Rancho Santa Margarita 22112 El Paseo, Rancho Santa Margarita, CA 92688	Wilson Leung (949) 635-1800 ext. 6506	Removal and replacement of ADA Curb Ramps at various locations	January 2024	\$ 128,199.75

14	Sidewalks and ADA Improvements Project No. 602600-23	City of Azusa 213 E. Foothill Blvd. Azusa, CA 91702	Christina Curiel 626-812-5247	Maintenance Project: R/R Sidewalk, Curb & Gutters, and Drive Approaches	April 2024	\$ 103,200.00
15	Apple Valley Road Bus Turnout Project No. 2023-03	Town of Apple Valley 14955 Dale Evans Pkwy Apple Valley, CA 92307	TBD	Construct a concrete transit bus pad, concrete curb, concrete sidewalk, relocate existing bus shelter	May 2024	\$ 100,343.00
16	Foothill Blvd Pavement Rehabilitation Project - Phase I	City of Azusa 213 E. Foothill Blvd. Azusa, CA 91702	Christina Curiel 626-812-5247		June 2024	\$ 1,796,307.30
17						



C. LIST OF COMPLETED PROJECTS - LAST THREE YEARS

[**Duplicate Page if needed for listing additional completed projects.**]

Please include only those projects which are similar enough to demonstrate Bidder's ability to perform the required Work.

Project Client	Description of Bidder's Work	Period of Performance	Cost of Bidder's Work	Contact Name & Phone
Please see attached				



C. List of Completed Projects

	Project Name	Client	Description of Bidder's Work	Date Completed	Cost of Bidder's Work	Contact Person & Phone No.
1	Park Plaza Safety Enhancement	City of Orange 300 E Chapman Ave Orange, CA 92866	R/R bollards, sidewalk, and ADA Ramps	2/11/24	\$ 205,930.00	Salvador Munoz 714-744-5547
2	FY 22-23 Concrete Improvements Project	City of Monterey Park 320 W Newmark Ave, Monterey Park, CA 91754	Maintenance Project: R/R Sidewalk, Curb & Gutters, Bus Pads and ADA Ramps	12/1/23	\$ 1,571,233.00	Peter Shiau 626-877-1928
3	Concrete Rehabilitation Project FY 22-23	City of Rancho Cucamonga 10500 Civic Center Drive Rancho Cucamonga, CA 91730	Maintenance Project: R/R Sidewalk, Curb & Gutters, and ADA Ramps	11/28/23	\$ 471,295.00	Kenneth Fung (909) 477-2730 ext 4139
4	Kathy Binks Elementary Safe Routes to School	City of Fontana 8353 Sierra Ave. Fontana, CA 92335	Maintenance Project: R/R Sidewalk, Curb & Gutters, and ADA Ramps	11/2/2023	\$ 479,053.68	Edgar Sanchez (909) 350-6523
5	CDBG Area 3 Curb Ramp Project	City of Diamond Bar 21810 Copley Dr. Diamond Bar, CA 91765	Maintenance Project: R/R Sidewalk, Curb & Gutters, and ADA Ramps	9/20/2023	\$ 164,494.00	Christian Malpica (909) 839-7042
6	Sidewalk and Curb Ramp Reconstruction Project (Phase 2), CIP 052	City of El Monte 11333 Valley Blvd El Monte, CA 91731	Maintenance Project: R/R Sidewalk, Curb & Gutters, and ADA Ramps	8/4/23	\$ 480,367.50	John Rico (626) 258-8833
7	CITYWIDE SIDEWALK, CURB & GUTTER REPLACEMENTS PROJECT No. 24009	City of Rosemead 8838 E Valley Blvd Rosemead, CA 91770	Maintenance Project: R/R Sidewalk, Curb & Gutters, and ADA Ramps	8/11/23	\$ 479,053.68	Leonardo Martinez (909) 595-8599
8	Sidewalk and Curb Ramp Reconstruction Project (Phase 3), CIP 052	City of El Monte 11333 Valley Blvd El Monte, CA 91731	Maintenance Project: R/R Sidewalk, Curb & Gutters, and ADA Ramps	6/17/2023	\$ 426,425.00	John Rico (626) 258-8833
9	Pedestrian Fencing Glenoaks Blvd Bridge Project	City of San Fernando 117 N Macneil St San Fernando, CA 91340	R/R sidewalk, drive approaches, ADA Curb Ramp, Asphalt Improvements & Striping	6/16/23	\$ 134,120.00	Jason Brown 562.908.6200
10	Victory Park Concrete Reconstruction Project	City of Pasadena 100 Garfield Ave Pasadena, CA 91101	R/R of concrete hardscape, cross gutter, and driveway apron. Reinstallation of bollards and truncated domes.	5/26/23	\$ 38,200.00	Jeff Khun 626-744-7389
11	State Street Sidewalk Improvements	City of Hemet 445 E. Florida Ave Hemet, CA 92543	Sidewalk Improvement Project	5/26/23	\$ 185,350.00	Noah Rau (951) 765-2360
12	CITYWIDE SIDEWALK, CURB & GUTTER REPAIRS	City of West Covina 1444 W Garvey Ave S West Covina, CA 91790	R/R Sidewalk and Curb and Gutter at various locations	5/16/23	\$ 169,138.00	Okan Demirci (714) 319-6137
13	CDBG ADA Concrete Ramps Construction	City of Ontario 1333 S. Bon View Ave Ontario, CA 91761	Remove and replace ADA curb ramps at various locations	5/12/23	\$ 175,000.00	Daniel Leon 909-395-2632
14	Parkway Concrete Maintenance Project RMDJOC6734	Los Angeles County Dept. Public Works 900 S Fremont Ave Alhambra, CA 91803	Maintenance Project: R/R Sidewalk, Curb & Gutters, and Drive Approaches	4/20/23	\$ 750,000.00	Cesar Orellana (562) 869-1176

15	Residential Concrete Improvements	City of Santa Fe Springs 11710 E. Telegraph Rd Santa Fe Springs, CA 90670	Maintenance Project: R/R Sidewalk, Curb & Gutters, and Drive Approaches	4/27/23	\$ 404,030.60	Alex Flores (562) 868-0511, Ext 7507
16	Concrete Rehabilitation Project	City of Cypress 2575 Orange Ave Cypress, CA 90630	Maintenance Project: R/R Sidewalk, Curb & Gutters, and Drive Approaches	4/28/23	\$ 200,131.30	Arash Rostamian (925) 961-6170
17	Citywide Concrete Repairs Project Concrete Repairs/ Citywide Project No. P-915	City of Manhattan Beach 1400 Highland Ave, Manhattan Beach, CA 90266	Maintenance Project: R/R Sidewalk, Curb & Gutters, and Installation/Improvement of ADA Ramps	4/22/2023	\$ 192,900.00	Adilia Miller (310) 802-5362
18	Citywide Sidewalk Improvement Project CDBG	City of Pasadena 100 Garfield Ave Pasadena, CA 91101	Removal and replacement of PCC Sidewalk & Sidewalk Grinding at various locations	4/20/2023	\$ 388,900.00	Teddy Luong (626) 744 -3711
19	CIP 22-20 & CIP 22-21 Sun City & Lazy Creek Community Pedestrian Project	City of Menifee 29844 Haun Rd Menifee, CA 92586	R/R sidewalk, drive approaches, ADA Curb Ramp, Asphalt Improvements & Striping	April 2023	\$ 678,192.00	Diego Guillen (951) 723-3755
20	Olive Helghts Sidewalk Gap Closure	County of Orange Public Works 601 N Ross St Santa Ana, CA 92701	Maintenance Project: R/R Sidewalk, Curb & Gutters, and Drive Approaches	April 2023	\$ 372,281.00	Janet Lee 949-506-6965
21	Redondela Drive ADA Improvements	City of Rancho Palos Verdes 30940 Hawthorne Blvd Rancho Palos Verdes, CA 90275	Removal and replacement of ADA Curb Ramps	4/6/2023	\$ 242,088.00	Anthony Flores (562) 547-8555
22	Citywide ADA Improvement Project & Concrete Walkway Replacement	City of Norco 2870 Clark Ave Norco, CA 92860	Sidewalk Improvement Project	2/23/2023	\$ 204,785.00	Amanda Hamilton (951) 270-5633
23	On-Call Concrete Repair Services	City of Placentia 401 E Chapman Ave Placentia, CA 92870	Maintenance Project: R/R Sidewalk, Curb & Gutters, and Drive Approaches	2/1/2023	\$ 38,600.00	Masoud Sepahi, PE (714) 993-8132
24	FY 22-23 Annual Concrete Repair	City of Rancho Santa Margarita 22112 El Pasco, Rancho Santa Margarita, CA 92688	Removal and replacement of PCC Sidewalk at various locations	1/17/2023	\$ 120,435.00	Wilson Leung (949) 635-1800 ext. 6506
25	N Del Sol Neighborhood Traffic Management Program (NTMP)	City of Diamond Bar 21810 Copley Dr. Diamond Bar, CA 91765	Construction of raised speed cushions, roadside signs and pavement legend, centerline & edge line	2/17/2023	\$ 76,116.73	Fabian Auon, P.E. 909-839-7038
26	Green Street ADA Improvements	City of Claremont 207 Harvard Ave N Claremont, CA 91711	R/R sidewalk, drive approaches, ADA Curb Ramp, Asphalt Improvements & Striping	1/6/2023	\$ 80,100.00	Enrique Villalobos 909-399-5479
27	Ada Upgrades - Midway City	County of Orange Public Works 601 N Ross St Santa Ana, CA 92701	Maintenance Project: R/R Sidewalk, Curb & Gutters, and Drive Approaches	10/10/22	\$ 262,521.00	Janet Lee 949-506-6965
28	CDBG Curb, Gutter, and Sidewalk Replacement Project	City of Rialto 198 S Palm Ave Rialto, CA 92376	Maintenance Project: R/R Sidewalk, Curb & Gutters, and Drive Approaches	9/26/22	\$ 129,435.00	Rudy Victorio 909-820-2532
29	2021-2022 Concrete Program Project No. 11158	City of Yucaipa 34272 Yucaipa Blvd Yucaipa, CA 92399	Maintenance Project: R/R Sidewalk, Curb & Gutters, and Drive Approaches	10/7/2022	\$ 77,701.60	Kevin Garcia 909-797-2489, ext. 290
30	Sidewalk Rehabilitation Project	City of Maywood 4319 E Slauson Ave Maywood, CA 90270	Maintenance Project: R/R Sidewalk, Curb & Gutters, and Drive Approaches	11/9/2022	\$ 112,500.00	Okan Demirci, PE, QSD/P (714) 319-6137

31	ADA Curb Ramp Improvements	City of Moreno Valley 14177 Frederick St Moreno Valley, CA 92553	Remove and replace ADA curb ramps at various locations	8/30/22	\$ 651,300.00	Quang Nguyen 951-413-3159
32	Mayberry Ave Sidewalk Project, Project No. DD-0101	County of Riverside Transportation Department 14th Street Transportation Annex 3525 14th Street Riverside, CA 92501	Maintenance Project: R/R Sidewalk, Curb & Gutters, and Drive Approaches	8/21/2022	\$ 222,659.00	Justin Robbins (951) 955-6815
33	Parkway Concrete Maintenance Project RMDJOC6708	Los Angeles County Dept. Public Works 900 S Fremont Ave Alhambra, CA 91803	Maintenance Project: R/R Sidewalk, Curb & Gutters, and Drive Approaches	8/3/2022	\$ 3,000,000.00	Cesar Orellana (562) 869-1176
34	SP-4181; Annual Concrete Repalcement at Various Locations	City of Orange 300 E Chapman Ave Orange, CA 92866	Maintenance Project: R/R Sidewalk, Curb & Gutters, and Drive Approaches	7/21/2022	\$ 775,280.00	Salvador Munoz 714-744-5547
35	Concrete Repair Services Project No. SM 1718-1	City of Ontario 1333 S. Bon View Ave Ontario, CA 91761	Maintenance Project: R/R Sidewalk, Curb & Gutters, and Drive Approaches	6/22/2022	\$ 3,915,452.00	Tim Masot (909) 395-2624
36	Citywide Sidewalk and Curb Ramp Improvement Project	City of Glendora 116 E Foothill Blvd Glendora, CA 91741	Maintenance Project: R/R Sidewalk, Curb & Gutters, and Drive Approaches	5/9/2022	\$ 258,570.00	Alexis Escobar 626-852-4845
37	Yucaipa Fire Station	Department of Forestry	R/R of approx. 11500 SF of existing pavement, 150 ft of curb, fencing & gate	April 2022	\$ 269,249.64	Matthew McCleod (951) 320-6133
38	ADA Bus Stop Improvements	City of Arcadia 240 W Huntington Dr, Arcadia, CA 91007	Bus Stop Improvements at Various Locations	March 2022	\$ 138,612.00	Johnathan Doojphibulpol (626) 574-5484
39	CDBG ADA Wheelchair Access Ramp Project	City of Orange 300 E Chapman Ave Orange, CA 92866	Remove and replace ADA curb ramps at various locations	2/18/2022	\$ 94,700.00	Salvador Munoz 714-744-5547
40	Annual Concrete Repair Project	City of Rancho Santa Margarita 22112 El Paseo, Rancho Santa Margarita, CA 92688	Maintenance Project: R/R Sidewalk, Curb & Gutters, and Drive Approaches	2/18/22	\$ 79,275.00	Wilson Leung (949) 635-1800 ext. 6506
41	Parkway Concrete Maintenance Project RMDJOC6707	Los Angeles County Dept. Public Works 900 S Fremont Ave Alhambra, CA 91803	Maintenance Project: R/R Sidewalk, Curb & Gutters, and Drive Approaches	February 2022	\$ 2,500,000.00	Brian Le (562) 869-1176
42	Hemet Concrete Repairs IFB 21-053	Riverside Transportation Department	Removal and replacement of concrete bus pad and miscellaneous sidewalk repairs	January 2022	\$ 38,841.00	Lon-Det Givens 951-565-5184
43	Concrete Removal and Replacement at Various Locations	City of Anaheim 400 E. Vermont Ave, Anaheim, CA 92805	Maintenance Project: R/R Sidewalk, Curb & Gutters, ADA Ramps and Drive Approaches	9/8/2021	\$ 402,238.45	Lorenzo Rea 714-765-6893
44	2020-21 Annual Concrete Repair Project	City of Arcadia 240 W Huntington Dr, Arcadia, CA 91007	Maintenance Project: R/R Sidewalk, Curb & Gutters, and Drive Approaches	8/30/2021	\$ 61,145.00	Jan Balanay 626-254-2726
45	CDBG Annual Concrete Repair Program	City of Montebello 1600 W Beverly Blvd, Montebello, CA 90640	Maintenance Project: R/R Sidewalk, Curb & Gutters, and Drive Approaches	7/19/2021	\$ 277,000.00	Albert Mendoza (323) 532-0936
46	CDBG Sidewalk Improvements, Project No. 2018-14, NIB 21-009HC	City of Corona 400 S Vicentia Ave Corona, CA 92882	Maintenance Project: R/R Sidewalk, Curb & Gutters, and Drive Approaches	6/25/2021	\$ 470,841.00	Barry Ghaemi 951-739-4961
47	CDBG ADA Wheelchair Access Ramp Improvement Project	City of Orange 300 E Chapman Ave Orange, CA 92866	Removal and Replacement of ADA Curb Ramps	3/30/2021	\$ 118,925.00	Salvador Munoz 714-744-5547

48	Concrete Improvements Project	City of Azusa 213 E. Foothill Blvd. Azusa, CA 91702	Maintenance Project: R/R Sidewalk, Curb & Gutters, and Drive Approaches	8/18/2021	\$ 95,499.60	Christina Curiel 626-812-5247
49	Annual Concrete Repair Program (FY20-21)	City of Rancho Santa Margarita 22112 El Paseo, Rancho Santa Margarita, CA 92688	Removal and Replacement Sidewalk at Various Locations	7/14/2021	\$ 73,080.00	Wilson Leung (949) 635-1800 ext. 6506
50	FY 19/20 Sidewalk Repair Program	City of San Clemente 101 S El Camino Real San Clemente, CA 92672	Maintenance Project: R/R Sidewalk, Curb & Gutters, and Drive Approaches	3/13/2021	\$ 332,469.93	Chris Tanio (949) 361-6128
51	Citywide Concrete Repair FY 19/20	City of Rancho Cucamonga 10500 Civic Center Dr Rancho Cucamonga, CA 91730	Maintenance Project: R/R Sidewalk, Curb & Gutters, and Drive Approaches	4/23/2021	\$ 201,343.00	Richard Favela (909) 774-4107
52	Alley/ Sanitation Rehabilitation North/South Alley from Shaefer and "G" St. Btwn 6th St. and Central Ave Project	City of Chino P.O. Box 667 Chino, CA 91708	Alley Rehabilitation	1/4/2021	\$ 240,500.00	Daniel Vest (909) 334-3367
53	Sidewalk Rehabilitation Project C.I.P-CS-20-10	City of Claremont 1616 Monte Vista Ave, Claremont, CA 91711	Maintenance Project: R/R Sidewalk, Curb & Gutters, and Drive Approaches	1/28/2021	\$ 271,700.00	Joe Ciccone (909) 399-5431
54	(ADA) Pedestrian Accessibility Improvement Project: Phase 4	City of Laguna Woods 24264 El Toro Road Laguna Woods, CA 92637	Maintenance Project: R/R Sidewalk, Curb & Gutters, and Drive Approaches	1/9/2021	\$ 111,800.00	April Baumgarten (949) 639-0568
55	Concrete Sidewalk Repair to Various Sites Within the City of Pomona	City of Pomona Water Resources Department 148 N. Huntington St. Pomona, CA 91768	Maintenance Project: R/R Sidewalk, Curb & Gutters, and Drive Approaches	11/13/2020	\$ 12,310.00	Nichole Horton 909-620-2212
56	Sidewalk Installation	Department of State Hospitals - Metropolitan 11401 Bloomfield Ave Norwalk, CA 90650	Remove and replace concrete sidewalk	10/13/2020	\$ 70,031.31	Kesha Rogers Kesha.Rogers@dsh.ca.gov
57	Barrier Replacements for Cucamonga Creek Class 1 Bike Project	City of Rancho Cucamonga	Misc. Concrete and Asphalt Repairs	10/21/2020	\$ 27,975.00	Gianfranco Laurie (909) 774-4037
58	Concrete Rehabilitation Project No. 238	City of Cypress 2575 Orange Ave Cypress, CA 90630	Maintenance Project: R/R Sidewalk, Curb & Gutters, and Drive Approaches	10/8/2020	\$ 259,650.00	Alex A Bangean (714) 229-6740
59	Sidewalk Rehabilitation Project 20-6	City of Claremont 1616 Monte Vista Ave, Claremont, CA 91711	Maintenance Project: R/R Sidewalk, Curb & Gutters, and Drive Approaches	9/9/2020	\$ 350,500.00	Joe Ciccone (909) 399-5431
60	2020 Miscellaneous Concrete Repair	City of La Canada Flintridge One Civic Center Drive, La Cañada Flintridge, CA 91011	Maintenance Project: R/R Sidewalk, Curb & Gutters, and Drive Approaches	8/18/2020	\$ 109,200.00	Maged El-Rabaa, P.E. (818) 790-8882, Ext 205
61	CDBG Curb Ramp Project	City of Hemet 445 E. Florida Ave Hemet, CA 92543	Installation of ADA Curb Ramps	8/18/2020	\$ 211,975.00	Chase Keys (951) 475-3613
62	Concrete Repair Services Project No 2018-153	City of Chino P.O. Box 667 Chino, CA 91708	Maintenance Project: R/R Sidewalk, Curb & Gutters, and Drive Approaches	Jun-20	\$ 326,383.75	Jesse Lopez (909) 334-3266

63	Parkway Concrete Maintenance District 1 Group C (6662) - Rio Hondo Phase 2	County of Los Angeles Public Works 900 S Fremont Ave Alhambra, CA 91803	Maintenance Project: R/R Sidewalk, Curb & Gutters, and Drive Approaches	6/16/2020	\$ 600,000.00	Jose Reyes (626) 337-1277
64	Parkway Concrete Maintenance District 1 Group B (6661) - Sunshine Park	County of Los Angeles Public Works 900 S Fremont Ave Alhambra, CA 91804	Maintenance Project: R/R Sidewalk, Curb & Gutters, and Drive Approaches	6/5/2020	\$ 1,500,000.00	Steven Lu (626) 337-1277
65	Harrison Ave Hardscape Repair Project	City of Claremont 207 Harvard, Claremont, CA 91711	Miscellaneous Hardscape Repairs	6/28/2020	\$ 24,900.00	Joe Ciccone (909) 399-5431
66	Parkway Concrete Maintenance District 4 Group E	County of Los Angeles Public Works 900 S Fremont Ave Alhambra, CA 91804	Maintenance Project: R/R Sidewalk, Curb & Gutters, and Drive Approaches	Jul-20	\$ 500,000.00	Paul Boice (626) 377-1277
67	FY 19-20 Citywide Sidewalk & Concrete Repairs Project	City of Walnut 21201 La Puente Rd Walnut, CA 91789	Maintenance Project: R/R Sidewalk, Curb & Gutters, and ADA Ramps	5/26/2020	\$ 139,542.00	Art Casillas (909) 532-5021
68	CIP-CS-19-04 Sidewalk Mitigation Project	City of Claremont 207 Harvard, Claremont, CA 91711	Maintenance Project: R/R Sidewalk, Curb & Gutters, and Drive Approaches	4/21/2020	\$ 281,600.00	Joe Ciccone (909) 399-5431
69	Hart Park Pool Deck Repair	City of Orange Community Services Dept. 230 E. Chapman Ave, Orange, CA 92866	Remove and replace concrete pool deck; furnish and install diving board and tiles	3/6/20	\$ 271,888.28	Don Equitz (714) 532-6464
70	Concrete Infrastructure Revitalization Program: Golden Lantern	City of Laguna Niguel 30111 Crown Valley Pkwy, Laguna Niguel, CA 92677	Maintenance Project: R/R Sidewalk, Curb & Gutters, and ADA Ramps	2/15/2020	\$ 360,276.00	Jeff Metz (949) 362-4344
71	Casa De Colinas Safety Barrier Project	City of Laguna Niguel 30111 Crown Valley Pkwy, Laguna Niguel, CA 92677	Install concrete safety barrier	2/27/2020	\$ 62,400.00	Jeff Metz (949) 362-4344
72	FY 19-20 CDBG Curb Ramp Improvement Project	City of Rancho Santa Margarita 22112 El Paseo, Rancho Santa Margarita, CA 92688	Remove and replace ADA ramps	2/1/2020	\$ 128,940.00	Wilson Leung (949) 635-1800 ext. 6506
73	PW 19-18 ADA Improvements to City Parking Facilities Project	City of El Segundo 350 Main St, El Segundo, CA 90245	ADA Improvements to City Parking Facilities	1/22/2020	\$ 99,808.00	Orlando Rodriguez (310) 524-2252
74	CityWide Annual Concrete Repair and Replacement	City of Norwalk 12700 Norwalk Blvd Norwalk, CA 90650	Removal and replacement of sidewalk panels at various locations	1/16/2020	\$ 260,250.00	Daimen Rosales (562) 929-5527
75	FY19-20 Annual Citywide Concrete Repair Program	City of Rancho Santa Margarita 22112 El Paseo, Rancho Santa Margarita, CA 92688	Removal and replacement of sidewalk panels at various locations	1/22/2020	\$ 60,900.00	Wilson Leung (949) 635-1800 ext. 6506



D. EXPERIENCE AND TECHNICAL QUALIFICATIONS QUESTIONNAIRE

Personnel:

The Bidder shall identify the key personnel to be assigned to this project in a management, construction supervision or engineering capacity.

1. List each person's job title, name and percent of time to be allocated to this project:

Jose Carvajal, President - time to allocated - 45%

Richard Ramos, Project Manager - time to be allocated - 85%

Oswaldo De Anda, Superintendent - time to be allocated - 95%

2. Summarize each person's specialized education:

Jose Carvajal - Courses in concrete construction and civil p.w. management, CSLB License Holder

Richard Ramos - Certificate in construction management

Oswaldo Deanda - OSHA 10, First Air/CPR, Traffic Control Training

3. List each person's years of construction experience relevant to the project:

Jose Carvajal - 25+ years of construction experience

Richard Ramos - 6+ years of construction experience

Oswaldo Deanda - 10+ years of construction experience

4. Summarize such experience:

Jose Carvajal - Responsible for overseeing all daily operations at CT&T Concrete Paving Inc.

Richard Ramos - Managed over 25 public works projects from start to finish

Oswaldo Deanda - Responsible for overseeing all field operations on public works projects

Bidder agrees that personnel named in this Bid will remain on this Project until completion of all relevant Work, unless substituted by personnel of equivalent experience and qualifications approved in advance by the City.

INFORMATION REQUIRED OF BIDDERS



Additional Bidder's Statements:

If the Bidder feels that there is additional information which has not been included in the questionnaire above, and which would contribute to the qualification review, it may add that information in a statement here or on an attached sheet, appropriately marked:

None

E. VERIFICATION AND EXECUTION

These Bid Forms shall be executed only by a duly authorized official of the Bidder:
I declare under penalty of perjury under the laws of the State of California that the foregoing information is true and correct:

Name of Bidder	CT&T Concrete Paving Inc.
Signature	
Name and Title	Jose Carvajal, President
Dated	04/03/2024



NON-COLLUSION AFFIDAVIT
CITYWIDE SIDEWALK IMPROVEMENTS CIP R-24

I, Jose Carvajal, being first duly sworn, deposes and says that he is of CT&T Concrete Paving Inc. the party making the attached bid; that the bid is not made in the interest of, or on behalf of, any undisclosed person, partnership, company, association, organization, or corporation; that the bid is genuine and not collusive or sham; that the bidder has not directly or indirectly induced or solicited any other bidder to put in a false or sham bid, and has not directly or indirectly colluded, conspired, connived, or agreed with any bidder or anyone else to put in a sham bid, or that anyone shall refrain from bidding; that the bidder has not in any manner, directly or indirectly, sought by agreement, communication, or conference with anyone to fix the bid price of the bidder or any other bidder, or to fix any overhead, profit, or cost element of the bid price, or of that of any other bidder, or to secure any advantage against the public body awarding the contract of anyone interested in the proposed contract; that all statements contained in the bid are true; and, further, that the bidder has not, directly or indirectly, submitted his or her bid price or any breakdown thereof, or the contents thereof, or divulged information or data relative thereto, or paid, and will not pay, any fee to any corporation, partnership, company association, organization, bid depository, or to any member or agent thereof to effectuate a collusive or sham bid.

I certify (or declare) under penalty of perjury under the laws of the State of California that the foregoing is true and correct.

Name of Bidder CT&T Concrete Paving Inc.

Signature 

Name and Title Jose Carvajal, President

Dated 04/03/2024

**CERTIFICATION OF BIDDER
REGARDING NONSEGREGATED FACILITIES**

Project Name: Citywide Sidewalk Improvement

Name of Bidder: CT&T Concrete Paving Inc.

The above-named Bidder hereby certifies that:

I do not maintain or provide for my employees any segregated facilities at any of my establishments, and that I do not permit my employees to perform their services at any location, under my control, where segregated facilities are maintained. As used in this certification, the term "segregated facilities" means any waiting rooms, work areas, rest rooms, wash rooms, restaurants and other eating areas, time clocks, locker rooms or other dressing areas, parking lots, drinking fountains, recreation or entertainment areas, transportation, and housing facilities provided for employees which are segregated by explicit directive or are in fact segregated on the basis of race, color, religion, national origin, or because of habits, local customs, or otherwise.

I further agree to obtain identical certifications from all proposed subcontractors prior to the award of subcontracts exceeding \$10,000.

Signature:  _____

Name (Print): Jose Carvajal

Title: President

Date: 04/03/2024

**COUNTY OF RIVERSIDE'S
DEPARTMENT OF HOUSING AND WORKFORCE SOLUTIONS
SECTION 3 PROGRAM
OVERVIEW AND REQUIREMENTS**

The work to be performed under this contract is subject to the requirements of section 3 of the Housing and Urban Development Act of 1968, as amended, 12 U.S.C. 1701u (section 3). The purpose of section 3 is to ensure that employment and other economic opportunities generated by HUD assistance or HUD-assisted projects covered by section 3, shall, to the greatest extent feasible, be directed to low- and very low-income persons, particularly persons who are recipients of HUD assistance for housing or residents of the community in which Federal assistance is spent.

APPLICABILITY

- Recipients and sub-recipients of Section 3 covered assistance, including contractors and subcontractors that perform work on Section 3 covered contracts/projects, are required to comply with Section 3 requirements.
- Section 3 requirements do not apply to contractors who furnish only materials or supplies and do not undertake the installation of the materials or supplies.

SECTION 3 GOALS

Contracts over \$200,000 trigger Section 3. When triggered, best efforts must be made to extend Section 3 opportunities to verified Section 3 residents and business concerns to meet these safe harbor benchmarks:

1. Twenty-five percent (25%) of the total hours on a Section 3 project must be worked by Section 3 workers; and
2. Five percent (5%) of the total hours on a Section 3 project must be worked by Targeted Section 3 workers.

Contractors and subcontractors must make their best efforts to provide employment and training opportunities to Section 3 Workers and document such efforts to realize the Section 3 benchmarks. Contractors and subcontractors will be considered to have complied with Section 3, if they meet or exceed the Section 3 benchmarks, or certify that they have followed the prioritization of efforts in 24 CFR 75.9 and 24 CFR 75.19.

SECTION 3 REQUIREMENTS FOR BIDDERS/PROPOSERS

Section 3 Project Implementation Plan

- I. **Submittal of Section 3 Implementation Plan:**
Bidder/Proposer AND its first-tier subcontractors are to submit a completed Section 3 Implementation Plan in bid. **A “non-responsive” determination may be made due to non-submittal.**
- II. **Submittal of Supporting Documentation:**
Bidder/Proposer AND its first-tier subcontractors whose Utilization Plans indicate no subcontract awards to certified Section 3 Business Concerns will be required to submit, upon request by HWS supporting documentation for review and approval verifying efforts to outreach to and award subcontracts to Section 3 Business Concerns. **A “non-responsive” determination shall be made due to a lack of documented outreach to Section 3 Business Concerns by the Bidder/Proposer.**

Bidder/Proposer may be deemed “non-responsive” if Implementation Plan indicates the following: (1) Existing employees do not meet the definition of a Section 3 Worker; and (2) Bidder/Proposer does not agree to make a documented good faith effort to hire Section 3 Workers (when there is a need to hire new employees).



SECTION 3 REQUIREMENTS FOR AWARDEES

Section 3 Contract Language

All Section 3 covered contracts and subcontracts shall include the following language:

- I. The work to be performed under this contract is subject to the requirements of Section 3 of the Housing and Urban Development Act of 1968, as amended, 12 USC.1701u (Section 3). The purpose of Section 3 is to ensure that employment and other economic opportunities generated by HUD assistance, or HUD-assisted projects covered by Section 3, shall to the greatest extent feasible be directed to low and very low-income persons, particularly persons who are recipients of HUD assistance for housing.
- II. The parties to this contract agree to comply with HUD's regulations in 24 CFR part 75, which implement Section 3. As evidenced by their execution of this contract, the parties to this contract certify that they are under no contractual or other impediment that would prevent them from complying with the part 75 regulations.
- III. The contractor agrees to send to each labor organization or representative of workers with which the contractor has a collective bargaining agreement or other understanding, if any, a notice advising the labor organization or workers' representative of the contractor's commitments under this Section 3 Clause and will post copies of the notice in conspicuous places at the work site where both employees and applicants for training and employment positions can see the notice. The notice shall describe the Section 3 preference, shall set forth minimum number and job titles subject to hire, availability of apprenticeship and training positions, the qualifications for each; the name and location of the person(s) taking applications for each of the positions; and the anticipated date the work shall begin.
- IV. The contractor agrees to include this Section 3 Clause in every subcontract subject to compliance with regulations in 24 CFR part 75, and agrees to take appropriate actions, as provided in an applicable provision of the subcontract or in this Section 3 Clause, upon a finding that the subcontractor is in violation of the regulations in 24 CFR part 75. The contractor will not subcontract with any subcontractor where the contractor has notice or knowledge that the subcontractor has been found in violation of the regulations in 24 CFR part 75.
- V. The contractor will certify that any vacant employment positions, including training positions, that are filled (1) after the contractor is selected but before the contract is executed, and (2) with persons other than those to whom the regulations of 24 CFR part 75 require employment opportunities to be directed, were not filled to circumvent the contractor's obligations under 24 CFR part 75.
- VI. Noncompliance with HUD's regulations in 24 CFR part 75 may result in sanctions, termination of this contract for default, and debarment or suspension from future HUD assisted contracts.
- VII. With respect to work performed in connection with Section 3 covered Indian housing assistance, section 7(b) of the Indian Self-Determination and Education Assistance Act (25 USC 450e) also applies to the work to be performed under this contract. Section 7(b) requires that to the greatest extent feasible (i) preference and opportunities for training and employment shall be given to Indians and (ii) preference in the award of contracts and subcontracts shall be given to Indian organizations and Indian-owned Economic Enterprises. Parties to this contract that are subject to the provisions of Section 3 and section 7(b) agree to comply with Section 3 to the maximum extent feasible, but not in derogation of compliance with section 7(b).



Section 3 Quarterly Labor Hours Report

Contractors and subcontractors are to make good faith assessments of employees’ labor hours on Section 3 covered contracts/projects for the following:

- Total labor hours worked by all employees (excludes the total labor hours from professional services)
- Total labor hours worked by Section 3 Workers
- Total labor hours worked by Targeted Section 3 Workers

Contractors and subcontractors are to report their good faith assessments of labor hours on the Section 3 Quarterly Labor Hours Report. Exception: Contractors and subcontractors whose contracts are subject to prevailing wage laws are to submit their weekly certified payroll reports, instead of the Section 3 Quarterly Labor Hours Report.

Compliance Monitoring

Section 3 compliance monitoring will be performed by HWS Section 3/EOC Unit. **Contractors and subcontractors who submitted approved Utilization Plans shall maintain their approved percentages of Section 3 participation throughout the term of the contract/project. Contractors and/or subcontractors whose Utilization Plans projected no new hires must, to the greatest extent feasible, hire certified Section 3 Workers or Targeted Section 3 Workers, when the need to hire occurs.**

FREQUENCY OF MONITORING				
Contract Description	Contract Award/ Negotiation	Monthly	Quarterly	Completion
Construction and Maintenance (subject to prevailing wage)	X	X		X
Non-Construction (<3 months’ performance)	X			X
Non-Construction (>3 months’ performance)	X		X	X

Noncompliance with HUD’s regulations in 24CFR75 may result in sanctions, termination of contract for default, and debarment or suspension from future HUD-assisted contracts.

Section 3 Project Implementation Plan

General Submittal Instructions:

Bidder/Proposer AND its first-tier subcontractors are to submit a completed Section 3 Implementation Plan(s) in bid. **If not, A “non-responsive” determination may be made due to non-submittal.**

Project Information:

Project Name: Citywide Sidewalk Improvement Project	Bid/Solicitation #: CIP R-24
--	---------------------------------

Contractor **Subcontractor Information**

Company Name: CT&T Concrete Paving Inc.	Address: 324 S. Diamond Bar Blvd, PMB 275, Diamond Bar, CA
Authorized Representative: Jackie Carvajal	Title: Treasurer
Phone: 909-629-8000	Email: jackie@cttconcretepaving.com
Proposed Dollar Value of Contract or Subcontract:	
List if ELBE, DBE, DVBE, MBE, SB, SLBE or WBE (or “N/A” if non-applicable): N/A	

Section 3 Requirements

Employment and Training

To the greatest extent feasible, employment and training opportunities arising in connection with Section 3 projects shall be provided to Section 3 workers within the County of Riverside. Where feasible, priority for employment and training will be given to:

1. Section 3 workers residing within the service area or neighborhood of the project, and
2. Participants in YouthBuild programs.

Contracting

To the greatest extent feasible, work contracts awarded in connection with Section 3 projects shall be provided to business concerns that provide economic opportunities to Section 3 workers residing within the County of Riverside. Where feasible, priority for contracting opportunities will be given to:

1. Section 3 business concerns that provide economic opportunities to Section 3 workers residing within the service area or the neighborhood of the project, and
2. YouthBuild programs.

Compliance Benchmarks

To demonstrate compliance with Section 3, contractors are required to follow the prioritization of effort outlined above and meet or exceed the following safe harbor benchmarks:

1. 25 percent or more of the total number of labor hours worked by all workers on the project shall be performed by Section 3 workers, and
2. 5 percent or more of the total number of labor hours worked by all workers on the project shall be performed by Targeted Section 3 workers.

Definitions

- **Section 3 worker:** Any worker who currently fits or when hired within the past three years fits at least one of the following categories, as documented:
 - (1) The worker’s income for the previous or annualized calendar year is below the income

Section 3 Project Implementation Plan

- limit established by HUD (see Income Limits table below).
- (2) The worker is employed by a Section 3 business concern.
- (3) The worker is a YouthBuild participant.
- **Targeted Section 3 worker:** A Section 3 worker who is:
 - (1) A worker employed by a Section 3 business concern; or
 - (2) A worker who currently fits or when hired within the past three years fit at least one of the following categories, as documented:
 - (i) Living within the service area or the neighborhood of the project; or
 - (ii) A YouthBuild participant.
- **Service area or the neighborhood of the project:** An area within one mile of the Section 3 project or, if fewer than 5,000 people live within one mile of a Section 3 project, within a circle centered on the Section 3 project that is sufficient to encompass a population of 5,000 people according to the most recent U.S. Census.

HUD Income Limits

The table below shows the income limits set by HUD that determine eligibility for certain programs, including Section 3. HUD develops income limits based on Area Median Income (AMI) estimates and Fair Market Rent (FMR) area definitions. For more information, please see the HUD Income Limits Documentation System online at www.huduser.gov/portal/datasets/il.html.

Riverside County, CA MSA			
Fiscal Year	2023	2022	2021
Low-income (80% AMI)	\$52,000	\$49,300	44,250

1. Does your business qualify as a Section 3 business concern? YES NO

If you answered YES, complete the attached Section 3 Business Concern Form (Pg. 6), and submit with this Plan.

A **Section 3 business concern** is a business that satisfies **at least one** of the following criteria, as documented within the last six-month period:

- a. The business is at least 51% owned and controlled by low- or very low-income persons;
- b. The business is at least 51% owned and controlled by residents who currently live in public housing or Section 8-assisted housing; or
- c. Over 75% of the labor hours performed for the business over the prior three-month period were performed by Section 3 workers – i.e., workers who currently are, or when hired within the past three years were:
 - (i) low-income persons or
 - (ii) YouthBuild participants.

2. Do you have current employees whose annual income is below the income limit? See HUD Income Limits table. YES NO

If “YES,” prior to contract execution, the names of qualifying employees shall be provided to HWS.

3. Do you plan to hire new employees to perform on or support the contract, if awarded the contract? YES NO



Section 3 Project Implementation Plan

limit established by HUD (see Income Limits table below).

- (2) The worker is employed by a Section 3 business concern.
- (3) The worker is a YouthBuild participant.

- **Targeted Section 3 worker:** A Section 3 worker who is:
 - (1) A worker employed by a Section 3 business concern; or
 - (2) A worker who currently fits or when hired within the past three years fit at least one of the following categories, as documented:
 - (i) Living within the service area or the neighborhood of the project; or
 - (ii) A YouthBuild participant.
- **Service area or the neighborhood of the project:** An area within one mile of the Section 3 project or, if fewer than 5,000 people live within one mile of a Section 3 project, within a circle centered on the Section 3 project that is sufficient to encompass a population of 5,000 people according to the most recent U.S. Census.

HUD Income Limits

The table below shows the income limits set by HUD that determine eligibility for certain programs, including Section 3. HUD develops income limits based on Area Median Income (AMI) estimates and Fair Market Rent (FMR) area definitions. For more information, please see the HUD Income Limits Documentation System online at www.huduser.gov/portal/datasets/il.html.

Riverside County, CA MSA			
Fiscal Year	2023	2022	2021
Low-income (80% AMI)	\$52,000	\$49,300	44,250

1. Does your business qualify as a Section 3 business concern? YES NO

If you answered YES, complete the attached Section 3 Business Concern Form (Pg. 6), and submit with this Plan.

A **Section 3 business concern** is a business that satisfies at least one of the following criteria, as documented within the last six-month period:

- a. The business is at least 51% owned and controlled by low- or very low-income persons;
- b. The business is at least 51% owned and controlled by residents who currently live in public housing or Section 8-assisted housing; or
- c. Over 75% of the labor hours performed for the business over the prior three-month period were performed by Section 3 workers – i.e., workers who currently are, or when hired within the past three years were:
 - (i) low-income persons or
 - (ii) YouthBuild participants.

2. Do you have current employees whose annual income is below the income limit? See HUD Income Limits table. YES NO

If "YES," prior to contract execution, the names of qualifying employees shall be provided to HWS.

3. Do you plan to hire new employees to perform on or support the contract, if awarded the contract? YES NO

Section 3 Project Implementation Plan

If "YES," at a minimum, you must contact the HWS Section 3 Unit at RivCoCDBG@rivco.org to obtain examples of qualitative efforts to create employment.

4. Do you agree that when there is a need to hire new employees, a documented good faith effort shall be made to hire Section 3 Workers? YES NO

Implementation Plans that indicate a "No" response for question #4 may be deemed "non-responsive."

5. How many workers are needed to complete the project?

Please list the job classifications and number of workers your company will need to complete the contract work. Attach additional sheets if necessary.

Job classification (Office/Clerical, Manager, Engineer, Technician, Supervisor/Foreman, Electrician, Plumber, Laborer, Trainee, Security, etc.)	Total estimated number of workers needed	Number of workers in current workforce	Estimated number of additional workers needed
Office/ Clerical	2	6	0
Superintendent/ Foreman	1	5	0
Cement Mason	8	12	0
Laborer	5	10	0
Operator Engineer Group 3	2	4	0
Teamster Group 3	2	4	0
Apprentice Cement Mason	1	0	1
Apprentice Laborer	1	0	1



Section 3 Project Implementation Plan

8. Will you be using subcontractors on this project? YES NO

If "Yes", Bidder/Proposer is required, to the greatest extent feasible, to outreach to and award subcontracts to Section 3 Business Concerns. **AT A MINIMUM, YOU MUST, CONTACT THE HWS SECTION 3/EOC UNIT AT RivCoCDBG@rivco.org OR GO TO <https://rivcoeda.org/Departments/Housing/Community-Development-BlockGrant/CommunityDevelopment/Section-3-Program> TO OBTAIN "Examples of Efforts to Create Employment and Contracting Opportunities."**

Section 3 Business Concerns **must complete** the Section 3 Business Concern Form and **must be** certified by HWS. For ELBE, SLBE, SB, DBE, MBE, WBE or DVBE firms, please attach a copy of their certification(s). **List ALL** proposed subcontractors (including subconsultants) for this project on the table below.

Business name	Scope of work (trade or service description)	Section 3 business? Yes / No	Estimated contract value
			\$
			\$
			\$
			\$
			\$
			\$
			\$
			\$
			\$
			\$
			\$
			\$
			\$
			\$
			\$

4. Do you commit to engage in good faith efforts to meet or exceed the Section 3 Benchmarks? YES NO

Such qualitative efforts may include, but are not limited to:

- **Applicant Outreach –**
 - Engage in outreach efforts to generate job applicants who are Targeted Section 3 workers, including posting job openings at the job site, HUD Opportunity Portal, social media pages, and other platforms.

Section 3 Project Implementation Plan

- Clearly indicate Section 3 eligibility on all job postings, notifications, and advertisements with the following statement: “This is a Section 3 eligible job opportunity. We encourage applications from individuals that are low-income, live in public housing, and/or receive a Section 8 voucher.”
- Include the Section 3 Worker Self-Certification form in all job postings.
- One-Stop / YouthBuild Outreach – Engage in outreach or referrals with local YouthBuild programs, or other community organizations to assist with training and recruiting Section 3 and Targeted Section 3 workers.
- Training and Apprenticeship – Provide training or apprenticeship opportunities.
- Job Fairs – Hold one or more job fairs or sponsor a job informational meeting in the project area.
- Business Concern Outreach –
 - Engage in outreach efforts to identify and secure bids from Section 3 businesses by advertising notices of contracting opportunities and related information in local community papers.
 - Provide written notice to all known Section 3 business concerns, with sufficient time for interested businesses to respond to bid invitations.
 - Send notice of contracting opportunities to local community development organizations, business development organizations, or minority contracting associations.
 - State clearly in all notices that the contracting opportunity is Section 3 eligible and include a copy of the Section 3 Business Concern Certification form.
- Competition Assistance – Provide technical assistance to help Section 3 business concerns understand and bid on contracts.
- Contract Sizing – Size, split, or divide contracts into smaller jobs to facilitate participation by Section 3 business concerns, particularly where economies of scale or efficiency of delivery are not factors. [2 CFR 200.321(b)(3)]
- Bidder Viability Support – Provide bonding assistance, guaranties, or other efforts to support viable bids from Section 3 business concerns.
- Business Registries – Promote the use of business registries designed to create opportunities for disadvantaged and small businesses.

Additional activities and efforts aimed at increasing economic opportunities for Section 3 workers and businesses may include, but are not limited to:

- Employment Assistance – Provide technical assistance to help Section 3 workers compete for jobs, or connect them with assistance in seeking employment, including resume assistance, interview preparation, coaching, or job placement services.
- Work Readiness and Retention – Provide or refer Section 3 workers to services supporting work readiness and retention, such as interview clothing, licensing or testing fees, transportation, or childcare.
- Financial Literacy – Help Section 3 workers obtain financial literacy training or coaching.
- Education Assistance – Assist Section 3 workers to apply for or attend community college, four-year educational institution, or vocational/technical training.

5. Do you commit to prioritize your efforts in hiring, training, and contracting as required by the Section 3 regulations and outlined on page 1 of this Plan?

YES NO



SECTION 3 BUSINESS CONCERN FORM

Please complete this form to determine if your business may qualify as a Section 3 Business. Businesses that qualify will be contacted by HWS Section 3 Coordinator to complete a Section 3 Business Application and asked to provide additional documentation to verify their status as a Section 3 Business.

What is Section 3?

Section 3 is a provision of the Housing and Urban Development Act of 1968 (24 CFR Part 75) that requires recipients of certain HUD financial assistance, to the greatest extent possible, to provide job training, employment, and contract opportunities for low- or very low-income residents in connection with projects and activities in their neighborhood.

A business can qualify as Section 3 if it meets one of the following criteria:

- A. It is at least 51% owned and controlled by low- or very low-income persons;
- B. Over 75% of the labor hours performed for the business over the past three-month period were performed by workers who met at least one of the criteria below; or
- C. It is at least 51% owned and controlled by current public housing residents or residents who currently live in Section 8-assisted housing.

Workers must meet one of the following criteria for a business to qualify as Section 3 under item B above:

- Reside within one mile of the Section 3 project (or, if fewer than 5,000 people live within one mile of the Section 3 project, within a circle centered on the Section 3 project that is sufficient to encompass a population of 5,000 people according to the most recent U.S. Census);
- Be a HUD YouthBuild participant; or
- Income for the previous or annualized calendar year is below 80% of the current area median income for the area in which the worker resides. (Use the worker's annual gross income based on AMI for a single-person household.) HUD income limits can be found at <https://www.huduser.gov/portal/datasets/il.html>.)

Company Name: CT&T Concrete Paving Inc.		
Contact Person: Jackie Carvajal		
Address: 324 S. Diamond Bar Blvd, PMB 275		
City: Diamond Bar	State: CA	Zip: 91765
Phone: 909-629-8000	Email: jackie@cttconcretepaving.com	

I have reviewed the above information and my business **MAY QUALIFY** as a Section 3 Business. Please contact me about completing an application and certification.

Signature of Business Owner

04/03/2024
Date



Certification for Section 3 Compliance
(Required for Bidder and all Subcontractors)

Project Information:

Project Name: Citywide Sidealk Improvement Project	Bid/Solicitation #: CIP R-24
--	------------------------------

Contractor/Subcontractor Information:

Company Name: CT&T Concrete Paving Inc.	Address: 324 S. Diamond Bar Blvd, PMB 275, Diamond Bar, CA
Authorized Representative: Jackie Carvajal	Title: Treasurer
Phone: 909-629-8000	Email: jackie@cttconcretepaving.com

- I. By completing and signing this form, I agree to comply with all applicable requirements of Section 3 of the Housing and Urban Development Act of 1968 (24 CFR Part 75) and HWS' Section 3 requirements.

INITIAL HERE jc
- II. I understand that "to the greatest extent feasible," work contracts awarded in connection with Section 3 projects shall be provided to business concerns that provide economic opportunities to Section 3 workers following the prioritization efforts outlined in Section 3 regulation.

INITIAL HERE jc
- III. I understand that in the event any new employment opportunities are created as a result of this CDBG-funded project then "to the greatest extent feasible" employment and training opportunities shall be provided to Section 3 workers following the prioritization efforts outlined in Section 3 regulation.

INITIAL HERE jc
- IV. I understand the safe harbor benchmarks for Section 3 compliance and that if these benchmarks are not met the contractor will be required to report on the qualitative efforts made to meet the benchmarks.

INITIAL HERE jc
- V. I understand that I will be required to make good faith assessments of employee labor hours on Section 3 covered projects and submit quarterly and final Section 3 reports and supporting documentation.

INITIAL HERE jc
- VI. I understand that any and all sub-contracts and sub-tier agreements resulting from this CDBG-funded project are also subject to Section 3 compliance and that it will be the General/Prime Contractor's responsibility to ensure compliance from all subcontractors.

INITIAL HERE jc
- VII. I understand that noncompliance with HUD's regulations in 24 CFR Part 75 may result in sanctions, termination of contract for default, and debarment or suspension from future HUD-assisted contracts.

INITIAL HERE jc

I declare that all statements contained in this form and any accompanying documents are true and correct and made with full knowledge that all statements given are subject to investigation and that any false or dishonest answer to any question may be grounds for denial or revocation of funding or other penalties as prescribed under 18 U.S. Code § 1001.

Jackie Carvajal
 Name of President or Authorized Officer
Jackie Carvajal
 Signature and Title
 Treasurer

CT&T Concrete Paving Inc.
 Company Name
04/03/2024
 Date



**BIDDER CERTIFICATION ON
FEDERAL CONTRACT REQUIREMENTS**

Project Name: Citywide Sidewalk Improvement Project Bid/Solicitation #: CIP R-24

CERTIFICATION:

I hereby certify that I have reviewed and understand the diversified Federal construction contract-related requirements imposed on the Contractor(s) of HUD-funded construction projects, including but not limited to the following:

1. The subject project is being financed with Community Development Block Grant funds (24 CFR Part 570); and
2. This project and all related construction contracts are subject to the U.S. Department of Housing and Urban Development's Federal Labor Standards Provisions (HUD 4010 – revised 10/2023); and
3. This project is subject to all applicable laws and regulations as listed in the General Summary of these Special Federal Provisions; and
4. If my bid is \$200,000 or more, this project and all related contracts will be subject to Section 3 requirements (12 U.S.C.1701u); and
5. If the project is \$250,000 or more, this project and all related contracts will be subject to comply with the requirements of the Build America, Buy America (BABA) Act (41 USC 8301).

CONTRACTOR'S NAME: CT&T Concrete Paving Inc.

CONTRACTOR'S LICENSE NO.: 875627

ADDRESS: 324 S. Diamond Bar Blvd, PMB 275, Diamond Bar, CA 91765

AUTHORIZED REPRESENTATIVE: Jackie Carvajal (Print Name)

SIGNATURE: 

DATE: 04/03/2024



QUESTIONNAIRE REGARDING BIDDERS

Bidder has been engaged in the contracting business under the present name of
CT&T Concrete Paving Inc. _____, since _____ (Date).

Present business address is: 324 S. Diamond Bar Blvd, PMB 275, Diamond Bar, CA

Federal Tax ID: 202642225 Amount of Bid \$ _____

California Contractor's License No.: 875627 Expiration Date: 04/30/2026

UEI Number: 8A690 or CAGE Code: _____

Because this project is Federally funded, it is necessary to obtain information concerning minority and other group participation for statistical purposes. The U.S. Department of Housing and Urban Development (HUD) uses this information to determine the degree to which its programs are being utilized by minority business enterprises and targeted group contractors.

A minority enterprise is defined by the Federal Government as a business that is fifty-one percent (51%) or more "minority-owned". Please check the applicable box concerning the ownership of your business:

- American Indian or Native Alaskan
- Asian or Pacific Islander/Native Hawaiian
- Black/African American
- Hispanic
- White
- Hasidic Jews
- Other _____

A woman-owned enterprise is defined by the Federal Government as a business that is fifty-one percent (51%) or more woman-owned. Please check applicable box concerning the ownership of your business:

- Woman/Female owned Male owned

A Section 3 Contractor or Subcontractor is a business concern that is more than fifty-one percent (51%) owned by a low or very low-income person, or over 75 percent of the labor hours performed for the business over the prior three-month period are performed by Section 3 workers. Please check the applicable box concerning the ownership of your business:

- Section 3 Business concern Non-Section 3 Business concern

The United States Department of Housing and Urban Development (HUD) is authorized to solicit the information requested in this form by virtue of Title 12, United States Code, Section 1701 et seq., and other regulations. It will not be disclosed or released outside of HUD without your consent, except as required or permitted by law.

LIST OF SUBCONTRACTORS

SUBCONTRACTOR	FED. I.D.#	AMOUNT	ADDRESS/PHONE NO.
California Professional Eng.		\$160,000	19662 San Jose Ave La Puente, CA
V&A Tree Service		\$84,600.00	13221 Rainbow St Covina Grove, CA

SUPPLIERS

NAME OF SUPPLIER	ADDRESS/PHONE NO.	CONTRACT AMOUNT
Robertsons Ready Mix	800 800-834-7557	TBD

If the project is \$250,000 or more, this project and all related contracts will be subject to comply with the requirements of the Build America, Buy America (BABA) Act (41 USC 8301).

This form is to be completed and submitted with the bid package.



Certification for Section 3 Compliance
(Required for Bidder and all Subcontractors)

Project Information:

Project Name: Sidewalk Improvements	Bid/Solicitation #: R-24
-------------------------------------	--------------------------

Contractor/Subcontractor Information:

Company Name: California Professional Engineering, Inc.	Address: 19062 San Jose Ave La Puente, CA 91748
Authorized Representative: Van Nguyen	Title: President
Phone: (626) 810-1338	Email: estimating@cpengineeringinc.com

- I. By completing and signing this form, I agree to comply with all applicable requirements of Section 3 of the Housing and Urban Development Act of 1968 (24 CFR Part 75) and HWS' Section 3 requirements.
INITIAL HERE VN
- II. I understand that "to the greatest extent feasible," work contracts awarded in connection with Section 3 projects shall be provided to business concerns that provide economic opportunities to Section 3 workers following the prioritization efforts outlined in Section 3 regulation.
INITIAL HERE VN
- III. I understand that in the event any new employment opportunities are created as a result of this CDBG-funded project then "to the greatest extent feasible" employment and training opportunities shall be provided to Section 3 workers following the prioritization efforts outlined in Section 3 regulation.
INITIAL HERE VN
- IV. I understand the safe harbor benchmarks for Section 3 compliance and that if these benchmarks are not met the contractor will be required to report on the qualitative efforts made to meet the benchmarks.
INITIAL HERE VN
- V. I understand that I will be required to make good faith assessments of employee labor hours on Section 3 covered projects and submit quarterly and final Section 3 reports and supporting documentation.
INITIAL HERE VN
- VI. I understand that any and all sub-contracts and sub-tier agreements resulting from this CDBG-funded project are also subject to Section 3 compliance and that it will be the General/Prime Contractor's responsibility to ensure compliance from all subcontractors.
INITIAL HERE VN
- VII. I understand that noncompliance with HUD's regulations in 24 CFR Part 75 may result in sanctions, termination of contract for default, and debarment or suspension from future HUD-assisted contracts.
INITIAL HERE VN

I declare that all statements contained in this form and any accompanying documents are true and correct and made with full knowledge that all statements given are subject to investigation and that any false or dishonest answer to any question may be grounds for denial or revocation of funding or other penalties as prescribed under 18 U.S. Code § 1001.

 Van Nguyen
 Name of President or Authorized Officer
 President
 Signature and Title

 California Professional Engineering, Inc.
 Company Name
 04/03/2024
 Date



Section 3 Project Implementation Plan

General Submittal Instructions:

Bidder/Proposer AND its first-tier subcontractors are to submit a completed Section 3 Implementation Plan(s) in bid. If not, A "non-responsive" determination may be made due to non-submittal.

Project Information:

Project Name: Sidewalk Improvements	Bid/Solicitation #: CIP R-24
-------------------------------------	------------------------------

Contractor Subcontractor Information

Company Name: California Professional Engineering, Inc.	Address: 19062 San Jose Ave La Puente, CA 91748
Authorized Representative: Van Nguyen	Title: President
Phone: (626) 810-1338	Email: estimating@cpengineeringinc.com
Proposed Dollar Value of Contract or Subcontract:	
List if ELBE, DBE, DVBE, MBE, SB, SLBE or WBE (or "N/A" if non-applicable): DBE 31277	

Section 3 Requirements

Employment and Training

To the greatest extent feasible, employment and training opportunities arising in connection with Section 3 projects shall be provided to Section 3 workers within the County of Riverside. Where feasible, priority for employment and training will be given to:

1. Section 3 workers residing within the service area or neighborhood of the project, and
2. Participants in YouthBuild programs.

Contracting

To the greatest extent feasible, work contracts awarded in connection with Section 3 projects shall be provided to business concerns that provide economic opportunities to Section 3 workers residing within the County of Riverside. Where feasible, priority for contracting opportunities will be given to:

1. Section 3 business concerns that provide economic opportunities to Section 3 workers residing within the service area or the neighborhood of the project, and
2. YouthBuild programs.

Compliance Benchmarks

To demonstrate compliance with Section 3, contractors are required to follow the prioritization of effort outlined above and meet or exceed the following safe harbor benchmarks:

1. 25 percent or more of the total number of labor hours worked by all workers on the project shall be performed by Section 3 workers, and
2. 5 percent or more of the total number of labor hours worked by all workers on the project shall be performed by Targeted Section 3 workers.

Definitions

- **Section 3 worker:** Any worker who currently fits or when hired within the past three years fits at least one of the following categories, as documented:
 - (1) The worker's income for the previous or annualized calendar year is below the Income

Section 3 Project Implementation Plan

limit established by HUD (see Income Limits table below).

- (2) The worker is employed by a Section 3 business concern.
- (3) The worker is a YouthBuild participant.

- **Targeted Section 3 worker:** A Section 3 worker who is:
 - (1) A worker employed by a Section 3 business concern; or
 - (2) A worker who currently fits or when hired within the past three years fit at least one of the following categories, as documented:
 - (i) Living within the service area or the neighborhood of the project; or
 - (ii) A YouthBuild participant.
- **Service area or the neighborhood of the project:** An area within one mile of the Section 3 project or, if fewer than 5,000 people live within one mile of a Section 3 project, within a circle centered on the Section 3 project that is sufficient to encompass a population of 5,000 people according to the most recent U.S. Census.

HUD Income Limits

The table below shows the income limits set by HUD that determine eligibility for certain programs, including Section 3. HUD develops income limits based on Area Median Income (AMI) estimates and Fair Market Rent (FMR) area definitions. For more information, please see the HUD Income Limits Documentation System online at www.huduser.gov/portal/datasets/il.html.

Riverside County, CA MSA			
Fiscal Year	2023	2022	2021
Low-income (80% AMI)	\$52,000	\$49,300	44,250

1. Does your business qualify as a Section 3 business concern? YES NO

If you answered YES, complete the attached Section 3 Business Concern Form (Pg. 6), and submit with this Plan.

A Section 3 business concern is a business that satisfies at least one of the following criteria, as documented within the last six-month period:

- a. The business is at least 51% owned and controlled by low- or very low-income persons;
- b. The business is at least 51% owned and controlled by residents who currently live in public housing or Section 8-assisted housing; or
- c. Over 75% of the labor hours performed for the business over the prior three-month period were performed by Section 3 workers – i.e., workers who currently are, or when hired within the past three years were:
 - (i) low-income persons or
 - (ii) YouthBuild participants.

2. Do you have current employees whose annual income is below the income limit? See HUD Income Limits table. YES NO

If “YES,” prior to contract execution, the names of qualifying employees shall be provided to HWS.

3. Do you plan to hire new employees to perform on or support the contract, if awarded the contract? YES NO

Section 3 Project Implementation Plan

If "YES," at a minimum, you must contact the HWS Section 3 Unit at RivCoCDBG@rivco.org to obtain examples of qualitative efforts to create employment.

4. Do you agree that when there is a need to hire new employees, a documented good faith effort shall be made to hire Section 3 Workers? YES NO

Implementation Plans that indicate a "No" response for question #4 may be deemed "non-responsive."

5. How many workers are needed to complete the project?

Please list the job classifications and number of workers your company will need to complete the contract work. Attach additional sheets if necessary.

Job classification (Office/Clerical, Manager, Engineer, Technician, Supervisor/Foreman, Electrician, Plumber, Laborer, Trainee, Security, etc.)	Total estimated number of workers needed	Number of workers in current workforce	Estimated number of additional workers needed
1 electrician	1	13	0
1 laborer	1	52	0



Section 3 Project Implementation Plan

8. Will you be using subcontractors on this project? YES NO

If "Yes", Bidder/Proposer is required, to the greatest extent feasible, to outreach to and award subcontracts to Section 3 Business Concerns. **AT A MINIMUM, YOU MUST, CONTACT THE HWS SECTION 3/EOC UNIT AT RivCoCDBG@rivco.org OR GO TO <https://rivcoeda.org/Departments/Housing/Community-Development-BlockGrant/CommunityDevelopment/Section-3-Program> TO OBTAIN "Examples of Efforts to Create Employment and Contracting Opportunities."**

Section 3 Business Concerns **must complete** the Section 3 Business Concern Form and **must be** certified by HWS. For ELBE, SLBE, SB, DBE, MBE, WBE or DVBE firms, please attach a copy of their certification(s). **List ALL** proposed subcontractors (including subconsultants) for this project on the table below.

Business name	Scope of work (trade or service description)	Section 3 business? Yes / No	Estimated contract value
California Professional Engineering, Inc. (DBE)	Electrical	No	\$ 160,000
			\$
			\$
			\$
			\$
			\$
			\$
			\$
			\$
			\$
			\$
			\$
			\$

4. Do you commit to engage in good faith efforts to meet or exceed the Section 3 Benchmarks? YES NO

Such qualitative efforts may include, but are not limited to:

- Applicant Outreach --
 - Engage in outreach efforts to generate job applicants who are Targeted Section 3 workers, including posting job openings at the job site, HUD Opportunity Portal, social media pages, and other platforms.

Section 3 Project Implementation Plan

- Clearly indicate Section 3 eligibility on all job postings, notifications, and advertisements with the following statement: “This is a Section 3 eligible job opportunity. We encourage applications from individuals that are low-income, live in public housing, and/or receive a Section 8 voucher.”
- Include the Section 3 Worker Self-Certification form in all job postings.
- **One-Stop / YouthBuild Outreach** – Engage in outreach or referrals with local YouthBuild programs, or other community organizations to assist with training and recruiting Section 3 and Targeted Section 3 workers.
- **Training and Apprenticeship** – Provide training or apprenticeship opportunities.
- **Job Fairs** – Hold one or more job fairs or sponsor a job informational meeting in the project area.
- **Business Concern Outreach** –
 - Engage in outreach efforts to identify and secure bids from Section 3 businesses by advertising notices of contracting opportunities and related information in local community papers.
 - Provide written notice to all known Section 3 business concerns, with sufficient time for interested businesses to respond to bid invitations.
 - Send notice of contracting opportunities to local community development organizations, business development organizations, or minority contracting associations.
 - State clearly in all notices that the contracting opportunity is Section 3 eligible and include a copy of the Section 3 Business Concern Certification form.
- **Competition Assistance** – Provide technical assistance to help Section 3 business concerns understand and bid on contracts.
- **Contract Sizing** – Size, split, or divide contracts into smaller jobs to facilitate participation by Section 3 business concerns, particularly where economies of scale or efficiency of delivery are not factors. [2 CFR 200.321(b)(3)]
- **Bidder Viability Support** – Provide bonding assistance, guaranties, or other efforts to support viable bids from Section 3 business concerns.
- **Business Registries** – Promote the use of business registries designed to create opportunities for disadvantaged and small businesses.

Additional activities and efforts aimed at increasing economic opportunities for Section 3 workers and businesses may include, but are not limited to:

- **Employment Assistance** – Provide technical assistance to help Section 3 workers compete for jobs, or connect them with assistance in seeking employment, including resume assistance, interview preparation, coaching, or job placement services.
- **Work Readiness and Retention** – Provide or refer Section 3 workers to services supporting work readiness and retention, such as interview clothing, licensing or testing fees, transportation, or childcare.
- **Financial Literacy** – Help Section 3 workers obtain financial literacy training or coaching.
- **Education Assistance** – Assist Section 3 workers to apply for or attend community college, four-year educational institution, or vocational/technical training.

5. Do you commit to prioritize your efforts in hiring, training, and contracting as required by the Section 3 regulations and outlined on page 1 of this Plan? YES NO



Addendum No. 1
CIP R-24 Citywide Sidewalk Project

This addendum is for the purpose of adding, clarifying, or deleting certain information to the construction contract documents as follows:

Questions & Answers

1. Can the City provide the Engineer's estimate for the project?

City of Beaumont Response: The City does not provide an Engineer's estimate.

2. Does the City have a pole foundation detail for the relocation of the candlestick light poles? Does the contractor need to provide an engineered drawing for the new foundations?

City of Beaumont Response: The Pole detail is attached for reference. The contractor will provide a construction submittal for the foundations. The foundation for the poles is specified as follows:

All poles will have a thirty-inch round or square in-ground base with a depth of forty-eight (48) inches from top of curb, and a minimum forty-two (42) inches of concrete base depth. Washers will be installed above and below the one-inch pole-mounting flange. Anchor bolts, washers and nuts will all be hot dipped galvanized steel per pole manufacturer specifications. All poles are to be placed behind the curb with a center of pole measurement of eighteen (18) inches from the face of curb to the center of pole. Concrete for pole bases shall be a public works design mix with test strength of 3250 PSI.

3. Is the award limit on the project still \$520,000?

City of Beaumont Response: The award limit provided in the NIB and in the instruction to bidders has been **decreased**. The award limit for the project is now **\$484,000**. The contract award cannot be more than this amount.

Attachments

The following attachments are made a part of this addendum.

- Sign-in sheet from the Mandatory Pre-Bid Meeting held on March 6, 2024.
- Candlestick light pole detail



Dated: March 13, 2024

By: CT&T Concrete Paving Inc.
(Bidder's Company Name)

Date Received by Bidder:

[Handwritten Signature]
(Bidder's Signature)

03/17/24

Jose Carraval
(Type or Print Name)

Bidder shall include a signed copy of this Addendum No. 1 with the bid proposal.

End of Addendum No. 1



Addendum No. 2
CIP R-24 Citywide Sidewalk Improvements

This Addendum is for the purpose of adding, clarifying, or deleting certain information to the construction contract documents as follows:

Federal Wage Determination

The following shall be considered as incorporated into the Bid Specifications for the aforementioned project. Information not specifically mentioned in this Addendum shall remain in force.

- **Remove** Appendix B – Prevailing Wage Determination (CA20240025, **Modification 2** dated 1/19/2024); **Replace** with Appendix B – Wage Determination (CA20240025, **Modification 4** dated 3/8/2024).

Bidders are hereby notified; Addendum No. 2 must be acknowledged as stipulated in the Bid Specification instructions. Failure to do so shall result in the City designating such proposal as incomplete or "Non-Responsive".

APPROVED

A handwritten signature in black ink, appearing to read "Robert Vestal", written over a horizontal line.

Robert Vestal, P.E.
Director of Public Works/City Engineer

End of Addendum No. 2

CITY OF BEAUMONT
PUBLIC WORKS AGREEMENT

EXHIBIT "C"

Insurance Certificates and Endorsements



CERTIFICATE OF LIABILITY INSURANCE

DATE (MM/DD/YYYY)

04/23/2024

THIS CERTIFICATE IS ISSUED AS A MATTER OF INFORMATION ONLY AND CONFERS NO RIGHTS UPON THE CERTIFICATE HOLDER. THIS CERTIFICATE DOES NOT AFFIRMATIVELY OR NEGATIVELY AMEND, EXTEND OR ALTER THE COVERAGE AFFORDED BY THE POLICIES BELOW. THIS CERTIFICATE OF INSURANCE DOES NOT CONSTITUTE A CONTRACT BETWEEN THE ISSUING INSURER(S), AUTHORIZED REPRESENTATIVE OR PRODUCER, AND THE CERTIFICATE HOLDER.

IMPORTANT: If the certificate holder is an ADDITIONAL INSURED, the policy(ies) must have ADDITIONAL INSURED provisions or be endorsed. If SUBROGATION IS WAIVED, subject to the terms and conditions of the policy, certain policies may require an endorsement. A statement on this certificate does not confer rights to the certificate holder in lieu of such endorsement(s).

PRODUCER McRae Associates Insurance Services 1265 N. Manassero St Suite 303 Anaheim, CA 92807 License #: 0637431	CONTACT NAME: Maricela Aguirre
	PHONE (A/C, No, Ext): (714)779-6999 FAX (A/C, No): (714)779-6903
	E-MAIL ADDRESS: maricela@mcraeinsurance.insure
	INSURER(S) AFFORDING COVERAGE
	NAIC #
INSURED CT & T CONCRETE PAVING, INC. 324 S DIAMOND BAR BLVD. PMB 275 DIAMOND BAR, CA 91765	INSURER A: THE TRAVELERS INDEMNITY COMPANY OF CONNECTICUT 25682
	INSURER B: TRAVELERS PROPERTY CASUALTY COMPANY OF AMERICA 25674
	INSURER C: THE TRAVELERS INDEMNITY COMPANY OF CONNECTICUT
	INSURER D: TRAVELERS PROPERTY CASUALTY COMPANY OF AMERICA
	INSURER E: GREAT AMERIAN INSURANCE 22136
	INSURER F: THE TRAVELERS INDEMNITY COMPANY OF CONNETICUT 25682

COVERAGES CERTIFICATE NUMBER: 00001005-1881628 REVISION NUMBER: 22

THIS IS TO CERTIFY THAT THE POLICIES OF INSURANCE LISTED BELOW HAVE BEEN ISSUED TO THE INSURED NAMED ABOVE FOR THE POLICY PERIOD INDICATED. NOTWITHSTANDING ANY REQUIREMENT, TERM OR CONDITION OF ANY CONTRACT OR OTHER DOCUMENT WITH RESPECT TO WHICH THIS CERTIFICATE MAY BE ISSUED OR MAY PERTAIN, THE INSURANCE AFFORDED BY THE POLICIES DESCRIBED HEREIN IS SUBJECT TO ALL THE TERMS, EXCLUSIONS AND CONDITIONS OF SUCH POLICIES. LIMITS SHOWN MAY HAVE BEEN REDUCED BY PAID CLAIMS.

INSR LTR	TYPE OF INSURANCE	ADDL INSD	SUBR WVD	POLICY NUMBER	POLICY EFF (MM/DD/YYYY)	POLICY EXP (MM/DD/YYYY)	LIMITS
A	<input checked="" type="checkbox"/> COMMERCIAL GENERAL LIABILITY <input type="checkbox"/> CLAIMS-MADE <input type="checkbox"/> OCCUR GEN'L AGGREGATE LIMIT APPLIES PER: <input checked="" type="checkbox"/> POLICY <input type="checkbox"/> PRO-JECT <input type="checkbox"/> LOC OTHER:	Y	Y	DT22-CO-2X94621A-X TCT-23	10/01/2023	10/01/2024	EACH OCCURRENCE \$ 1,000,000 DAMAGE TO RENTED PREMISES (Ea occurrence) \$ 300,000 MED EXP (Any one person) \$ 5,000 PERSONAL & ADV INJURY \$ 1,000,000 GENERAL AGGREGATE \$ 2,000,000 PRODUCTS - COMP/OP AGG \$ 2,000,000
B	AUTOMOBILE LIABILITY <input type="checkbox"/> ANY AUTO <input type="checkbox"/> OWNED AUTOS ONLY <input type="checkbox"/> HIRED AUTOS ONLY <input type="checkbox"/> SCHEDULED AUTOS <input type="checkbox"/> NON-OWNED AUTOS ONLY	Y	Y	810-2X930002-23-26-G	10/01/2023	10/01/2024	COMBINED SINGLE LIMIT (Ea accident) \$ 1,000,000 BODILY INJURY (Per person) \$ BODILY INJURY (Per accident) \$ PROPERTY DAMAGE (Per accident) \$
C	<input checked="" type="checkbox"/> UMBRELLA LIAB <input checked="" type="checkbox"/> OCCUR <input type="checkbox"/> EXCESS LIAB <input type="checkbox"/> CLAIMS-MADE DED RETENTION \$	Y	Y	CUP-2X94920A-23-26	10/01/2023	10/01/2024	EACH OCCURRENCE \$ AGGREGATE \$
D	WORKERS COMPENSATION AND EMPLOYERS' LIABILITY ANY PROPRIETOR/PARTNER/EXECUTIVE OFFICER/MEMBER EXCLUDED? (Mandatory in NH) If yes, describe under DESCRIPTION OF OPERATIONS below		Y	UB-2X937955-23-26-G	10/01/2023	10/01/2024	<input checked="" type="checkbox"/> PER STATUTE <input type="checkbox"/> OTHER E.L. EACH ACCIDENT \$ 1,000,000 E.L. DISEASE - EA EMPLOYEE \$ 1,000,000 E.L. DISEASE - POLICY LIMIT \$ 1,000,000
E	PROPERTY/INLAND MAR			MACE2289310201	04/27/2023	04/27/2024	SCHEDULED EQUIPMENT \$ 129,692
F	OWNERS & CONTR. PROT			2X94621A	12/08/2023	12/08/2024	EACH OCC/ GEN \$ 10 MILL / \$2 MILL

DESCRIPTION OF OPERATIONS / LOCATIONS / VEHICLES (ACORD 101, Additional Remarks Schedule, may be attached if more space is required)

The City of Beaumont, its elected and appointed officers, employees, agents and volunteers are named as additional insured as required by written contract with respect to General Liability and Auto Liability. 30 Days' Notice of Cancellation to certificate holder, 10 days for non-payment of premium applies

* Should any of the above-described policies be cancelled before the expiration date thereof, a 30 day written notice will be issued.

CERTIFICATE HOLDER

CANCELLATION

City of Beaumont
550 E. 6th Street
Beaumont, CA 92223

SHOULD ANY OF THE ABOVE DESCRIBED POLICIES BE CANCELLED BEFORE THE EXPIRATION DATE THEREOF, NOTICE WILL BE DELIVERED IN ACCORDANCE WITH THE POLICY PROVISIONS.

AUTHORIZED REPRESENTATIVE

(MAG)

© 1988-2015 ACORD CORPORATION. All rights reserved.

THIS ENDORSEMENT CHANGES THE POLICY. PLEASE READ IT CAREFULLY.

BUSINESS AUTO EXTENSION ENDORSEMENT

This endorsement modifies insurance provided under the following:

BUSINESS AUTO COVERAGE FORM

GENERAL DESCRIPTION OF COVERAGE – This endorsement broadens coverage. However, coverage for any injury, damage or medical expenses described in any of the provisions of this endorsement may be excluded or limited by another endorsement to the Coverage Part, and these coverage broadening provisions do not apply to the extent that coverage is excluded or limited by such an endorsement. The following listing is a general coverage description only. Limitations and exclusions may apply to these coverages. Read all the provisions of this endorsement and the rest of your policy carefully to determine rights, duties, and what is and is not covered.

- | | |
|---|---|
| <ul style="list-style-type: none"> A. BROAD FORM NAMED INSURED B. BLANKET ADDITIONAL INSURED C. EMPLOYEE HIRED AUTO D. EMPLOYEES AS INSURED E. SUPPLEMENTARY PAYMENTS – INCREASED LIMITS F. HIRED AUTO – LIMITED WORLDWIDE COVERAGE – INDEMNITY BASIS G. WAIVER OF DEDUCTIBLE – GLASS | <ul style="list-style-type: none"> H. HIRED AUTO PHYSICAL DAMAGE – LOSS OF USE – INCREASED LIMIT I. PHYSICAL DAMAGE – TRANSPORTATION EXPENSES – INCREASED LIMIT J. PERSONAL PROPERTY K. AIRBAGS L. NOTICE AND KNOWLEDGE OF ACCIDENT OR LOSS M. BLANKET WAIVER OF SUBROGATION N. UNINTENTIONAL ERRORS OR OMISSIONS |
|---|---|

PROVISIONS

A. BROAD FORM NAMED INSURED

The following is added to Paragraph **A.1., Who Is An Insured**, of **SECTION II – COVERED AUTOS LIABILITY COVERAGE**:

Any organization you newly acquire or form during the policy period over which you maintain 50% or more ownership interest and that is not separately insured for Business Auto Coverage. Coverage under this provision is afforded only until the 180th day after you acquire or form the organization or the end of the policy period, whichever is earlier.

B. BLANKET ADDITIONAL INSURED

The following is added to Paragraph **c. in A.1., Who Is An Insured**, of **SECTION II – COVERED AUTOS LIABILITY COVERAGE**:

Any person or organization who is required under a written contract or agreement between you and that person or organization, that is signed and executed by you before the "bodily injury" or "property damage" occurs and that is in effect during the policy period, to be named as an additional insured is an "insured" for Covered Autos Liability Coverage, but only for damages to which

this insurance applies and only to the extent that person or organization qualifies as an "insured" under the Who Is An Insured provision contained in Section II.

C. EMPLOYEE HIRED AUTO

1. The following is added to Paragraph **A.1., Who Is An Insured**, of **SECTION II – COVERED AUTOS LIABILITY COVERAGE**:

An "employee" of yours is an "insured" while operating an "auto" hired or rented under a contract or agreement in an "employee's" name, with your permission, while performing duties related to the conduct of your business.

2. The following replaces Paragraph **b. in B.5., Other Insurance**, of **SECTION IV – BUSINESS AUTO CONDITIONS**:

b. For Hired Auto Physical Damage Coverage, the following are deemed to be covered "autos" you own:

- (1) Any covered "auto" you lease, hire, rent or borrow; and
- (2) Any covered "auto" hired or rented by your "employee" under a contract in an "employee's" name, with your

COMMERCIAL AUTO

permission, while performing duties related to the conduct of your business.

However, any "auto" that is leased, hired, rented or borrowed with a driver is not a covered "auto".

D. EMPLOYEES AS INSURED

The following is added to Paragraph A.1., **Who Is An Insured**, of SECTION II – COVERED AUTOS LIABILITY COVERAGE:

Any "employee" of yours is an "insured" while using a covered "auto" you don't own, hire or borrow in your business or your personal affairs.

E. SUPPLEMENTARY PAYMENTS – INCREASED LIMITS

1. The following replaces Paragraph A.2.a.(2), of SECTION II – COVERED AUTOS LIABILITY COVERAGE:

(2) Up to \$3,000 for cost of bail bonds (including bonds for related traffic law violations) required because of an "accident" we cover. We do not have to furnish these bonds.

2. The following replaces Paragraph A.2.a.(4), of SECTION II – COVERED AUTOS LIABILITY COVERAGE:

(4) All reasonable expenses incurred by the "insured" at our request, including actual loss of earnings up to \$500 a day because of time off from work.

F. HIRED AUTO – LIMITED WORLDWIDE COVERAGE – INDEMNITY BASIS

The following replaces Subparagraph (5) in Paragraph B.7., **Policy Period, Coverage Territory**, of SECTION IV – BUSINESS AUTO CONDITIONS:

(5) Anywhere in the world, except any country or jurisdiction while any trade sanction, embargo, or similar regulation imposed by the United States of America applies to and prohibits the transaction of business with or within such country or jurisdiction, for Covered Autos Liability Coverage for any covered "auto" that you lease, hire, rent or borrow without a driver for a period of 30 days or less and that is not an "auto" you lease, hire, rent or borrow from any of your "employees", partners (if you are a partnership), members (if you are a limited liability company) or members of their households.

(a) With respect to any claim made or "suit" brought outside the United States of America, the territories and possessions of the United States of America, Puerto Rico and Canada:

(i) You must arrange to defend the "insured" against, and investigate or settle any such claim or "suit" and keep us advised of all proceedings and actions.

(ii) Neither you nor any other involved "insured" will make any settlement without our consent.

(iii) We may, at our discretion, participate in defending the "insured" against, or in the settlement of, any claim or "suit".

(iv) We will reimburse the "insured" for sums that the "insured" legally must pay as damages because of "bodily injury" or "property damage" to which this insurance applies, that the "insured" pays with our consent, but only up to the limit described in Paragraph C., **Limits Of Insurance**, of SECTION II – COVERED AUTOS LIABILITY COVERAGE.

(v) We will reimburse the "insured" for the reasonable expenses incurred with our consent for your investigation of such claims and your defense of the "insured" against any such "suit", but only up to and included within the limit described in Paragraph C., **Limits Of Insurance**, of SECTION II – COVERED AUTOS LIABILITY COVERAGE, and not in addition to such limit. Our duty to make such payments ends when we have used up the applicable limit of insurance in payments for damages, settlements or defense expenses.

(b) This insurance is excess over any valid and collectible other insurance available to the "insured" whether primary, excess, contingent or on any other basis.

(c) This insurance is not a substitute for required or compulsory insurance in any country outside the United States, its territories and possessions, Puerto Rico and Canada.

You agree to maintain all required or compulsory insurance in any such country up to the minimum limits required by local law. Your failure to comply with compulsory insurance requirements will not invalidate the coverage afforded by this policy, but we will only be liable to the same extent we would have been liable had you complied with the compulsory insurance requirements.

- (d) It is understood that we are not an admitted or authorized insurer outside the United States of America, its territories and possessions, Puerto Rico and Canada. We assume no responsibility for the furnishing of certificates of insurance, or for compliance in any way with the laws of other countries relating to insurance.

G. WAIVER OF DEDUCTIBLE – GLASS

The following is added to Paragraph D., **Deductible**, of **SECTION III – PHYSICAL DAMAGE COVERAGE**:

No deductible for a covered "auto" will apply to glass damage if the glass is repaired rather than replaced.

H. HIRED AUTO PHYSICAL DAMAGE – LOSS OF USE – INCREASED LIMIT

The following replaces the last sentence of Paragraph A.4.b., **Loss Of Use Expenses**, of **SECTION III – PHYSICAL DAMAGE COVERAGE**:

However, the most we will pay for any expenses for loss of use is \$65 per day, to a maximum of \$750 for any one "accident".

I. PHYSICAL DAMAGE – TRANSPORTATION EXPENSES – INCREASED LIMIT

The following replaces the first sentence in Paragraph A.4.a., **Transportation Expenses**, of **SECTION III – PHYSICAL DAMAGE COVERAGE**:

We will pay up to \$50 per day to a maximum of \$1,500 for temporary transportation expense incurred by you because of the total theft of a covered "auto" of the private passenger type.

J. PERSONAL PROPERTY

The following is added to Paragraph A.4., **Coverage Extensions**, of **SECTION III – PHYSICAL DAMAGE COVERAGE**:

Personal Property

We will pay up to \$400 for "loss" to wearing apparel and other personal property which is:

- (1) Owned by an "insured"; and

- (2) In or on your covered "auto".

This coverage applies only in the event of a total theft of your covered "auto".

No deductibles apply to this Personal Property coverage.

K. AIRBAGS

The following is added to Paragraph B.3., **Exclusions**, of **SECTION III – PHYSICAL DAMAGE COVERAGE**:

Exclusion 3.a. does not apply to "loss" to one or more airbags in a covered "auto" you own that inflate due to a cause other than a cause of "loss" set forth in Paragraphs A.1.b. and A.1.c., but only:

- a. If that "auto" is a covered "auto" for Comprehensive Coverage under this policy;
- b. The airbags are not covered under any warranty; and
- c. The airbags were not intentionally inflated.

We will pay up to a maximum of \$1,000 for any one "loss".

L. NOTICE AND KNOWLEDGE OF ACCIDENT OR LOSS

The following is added to Paragraph A.2.a., of **SECTION IV – BUSINESS AUTO CONDITIONS**:

Your duty to give us or our authorized representative prompt notice of the "accident" or "loss" applies only when the "accident" or "loss" is known to:

- (a) You (if you are an individual);
- (b) A partner (if you are a partnership);
- (c) A member (if you are a limited liability company);
- (d) An executive officer, director or insurance manager (if you are a corporation or other organization); or
- (e) Any "employee" authorized by you to give notice of the "accident" or "loss".

M. BLANKET WAIVER OF SUBROGATION

The following replaces Paragraph A.5., **Transfer Of Rights Of Recovery Against Others To Us**, of **SECTION IV – BUSINESS AUTO CONDITIONS**:

5. Transfer Of Rights Of Recovery Against Others To Us

We waive any right of recovery we may have against any person or organization to the extent required of you by a written contract signed and executed prior to any "accident" or "loss", provided that the "accident" or "loss" arises out of operations contemplated by

COMMERCIAL AUTO

such contract. The waiver applies only to the person or organization designated in such contract.

N. UNINTENTIONAL ERRORS OR OMISSIONS

The following is added to Paragraph B.2., **Concealment, Misrepresentation, Or Fraud**, of **SECTION IV – BUSINESS AUTO CONDITIONS**:

The unintentional omission of, or unintentional error in, any information given by you shall not prejudice your rights under this insurance. However this provision does not affect our right to collect additional premium or exercise our right of cancellation or non-renewal.

THIS ENDORSEMENT CHANGES THE POLICY. PLEASE READ IT CAREFULLY.

**BLANKET ADDITIONAL INSURED – PRIMARY AND
NON-CONTRIBUTORY WITH OTHER INSURANCE –
CONTRACTORS**

This endorsement modifies insurance provided under the following:

BUSINESS AUTO COVERAGE FORM

PROVISIONS

1. The following is added to Paragraph c. in A.1., **Who Is An Insured**, of **SECTION II – COVERED AUTOS LIABILITY COVERAGE**:

This includes any person or organization who you are required under a written contract or agreement, that is signed by you before the "bodily injury" or "property damage" occurs and that is in effect during the policy period, to name as an additional insured for Covered Autos Liability Coverage, but only for damages to which this insurance applies and only to the extent of that person's or organization's liability for the conduct of another "insured".

2. The following is added to Paragraph B.5., **Other Insurance** of **SECTION IV – BUSINESS AUTO CONDITIONS**:

Regardless of the provisions of paragraph a. and paragraph d. of this part 5. **Other Insurance**, this insurance is primary to and non-contributory with applicable other insurance under which an additional insured person or organization is a named insured when a written contract or agreement with you, that is signed by you before the "bodily injury" or "property damage" occurs and that is in effect during the policy period, requires this insurance to be primary and non-contributory.

THIS ENDORSEMENT CHANGES THE POLICY. PLEASE READ IT CAREFULLY.

BLANKET ADDITIONAL INSURED
(Includes Products-Completed Operations If Required By Contract)

This endorsement modifies insurance provided under the following:
 COMMERCIAL GENERAL LIABILITY COVERAGE PART

PROVISIONS

The following is added to **SECTION II – WHO IS AN INSURED:**

Any person or organization that you agree in a written contract or agreement to include as an additional insured on this Coverage Part is an insured, but only:

- a. With respect to liability for "bodily injury" or "property damage" that occurs, or for "personal injury" caused by an offense that is committed, subsequent to the signing of that contract or agreement and while that part of the contract or agreement is in effect; and
- b. If, and only to the extent that, such injury or damage is caused by acts or omissions of you or your subcontractor in the performance of "your work" to which the written contract or agreement applies. Such person or organization does not qualify as an additional insured with respect to the independent acts or omissions of such person or organization.

The insurance provided to such additional insured is subject to the following provisions:

- a. If the Limits of Insurance of this Coverage Part shown in the Declarations exceed the minimum limits required by the written contract or agreement, the insurance provided to the additional insured will be limited to such minimum required limits. For the purposes of determining whether this limitation applies, the minimum limits required by the written contract or agreement will be considered to include the minimum limits of any Umbrella or Excess liability coverage required for the additional insured by that written contract or agreement. This provision will not increase the limits of insurance described in Section III – Limits Of Insurance.
- b. The insurance provided to such additional insured does not apply to:

- (1) Any "bodily injury", "property damage" or "personal injury" arising out of the providing, or failure to provide, any professional architectural, engineering or surveying services, including:

- (a) The preparing, approving, or failing to prepare or approve, maps, shop drawings, opinions, reports, surveys, field orders or change orders, or the preparing, approving, or failing to prepare or approve, drawings and specifications; and
- (b) Supervisory, inspection, architectural or engineering activities.

- (2) Any "bodily injury" or "property damage" caused by "your work" and included in the "products-completed operations hazard" unless the written contract or agreement specifically requires you to provide such coverage for that additional insured during the policy period.

- c. The additional insured must comply with the following duties:

- (1) Give us written notice as soon as practicable of an "occurrence" or an offense which may result in a claim. To the extent possible, such notice should include:

- (a) How, when and where the "occurrence" or offense took place;
- (b) The names and addresses of any injured persons and witnesses; and
- (c) The nature and location of any injury or damage arising out of the "occurrence" or offense.

- (2) If a claim is made or "suit" is brought against the additional insured:

COMMERCIAL GENERAL LIABILITY

- (a) Immediately record the specifics of the claim or "suit" and the date received; and
- (b) Notify us as soon as practicable and see to it that we receive written notice of the claim or "suit" as soon as practicable.
- (3) Immediately send us copies of all legal papers received in connection with the claim or "suit", cooperate with us in the investigation or settlement of the claim or defense against the "suit", and otherwise comply with all policy conditions.
- (4) Tender the defense and indemnity of any claim or "suit" to any provider of other insurance which would cover such additional insured for a loss we cover. However, this condition does not affect whether the insurance provided to such additional insured is primary to other insurance available to such additional insured which covers that person or organization as a named insured as described in Paragraph 4., Other Insurance, of Section IV – Commercial General Liability Conditions.

THIS ENDORSEMENT CHANGES THE POLICY. PLEASE READ IT CAREFULLY.

XTEND ENDORSEMENT FOR CONTRACTORS

This endorsement modifies insurance provided under the following:

COMMERCIAL GENERAL LIABILITY COVERAGE PART

GENERAL DESCRIPTION OF COVERAGE – This endorsement broadens coverage. However, coverage for any injury, damage or medical expenses described in any of the provisions of this endorsement may be excluded or limited by another endorsement to this Coverage Part, and these coverage broadening provisions do not apply to the extent that coverage is excluded or limited by such an endorsement. The following listing is a general coverage description only. Read all the provisions of this endorsement and the rest of your policy carefully to determine rights, duties, and what is and is not covered.

- | | |
|--|---|
| <p>A. Who Is An Insured – Unnamed Subsidiaries</p> <p>B. Blanket Additional Insured – Governmental Entities – Permits Or Authorizations Relating To Operations</p> | <p>C. Incidental Medical Malpractice</p> <p>D. Blanket Waiver Of Subrogation</p> <p>E. Contractual Liability – Railroads</p> <p>F. Damage To Premises Rented To You</p> |
|--|---|

PROVISIONS

A. WHO IS AN INSURED – UNNAMED SUBSIDIARIES

The following is added to **SECTION II – WHO IS AN INSURED**:

Any of your subsidiaries, other than a partnership, joint venture or limited liability company, that is not shown as a Named Insured in the Declarations is a Named Insured if:

- a. You are the sole owner of, or maintain an ownership interest of more than 50% in, such subsidiary on the first day of the policy period; and
- b. Such subsidiary is not an insured under similar other insurance.

No such subsidiary is an insured for "bodily injury" or "property damage" that occurred, or "personal and advertising injury" caused by an offense committed:

- a. Before you maintained an ownership interest of more than 50% in such subsidiary; or
- b. After the date, if any, during the policy period that you no longer maintain an ownership interest of more than 50% in such subsidiary.

For purposes of Paragraph 1. of Section II – Who Is An Insured, each such subsidiary will be deemed to be designated in the Declarations as:

- a. An organization other than a partnership, joint venture or limited liability company; or

- b. A trust;

as indicated in its name or the documents that govern its structure.

B. BLANKET ADDITIONAL INSURED – GOVERNMENTAL ENTITIES – PERMITS OR AUTHORIZATIONS RELATING TO OPERATIONS

The following is added to **SECTION II – WHO IS AN INSURED**:

Any governmental entity that has issued a permit or authorization with respect to operations performed by you or on your behalf and that you are required by any ordinance, law, building code or written contract or agreement to include as an additional insured on this Coverage Part is an insured, but only with respect to liability for "bodily injury", "property damage" or "personal and advertising injury" arising out of such operations.

The insurance provided to such governmental entity does not apply to:

- a. Any "bodily injury", "property damage" or "personal and advertising injury" arising out of operations performed for the governmental entity; or
- b. Any "bodily injury" or "property damage" included in the "products-completed operations hazard".

C. INCIDENTAL MEDICAL MALPRACTICE

1. The following replaces Paragraph **b.** of the definition of "occurrence" in the **DEFINITIONS** Section:

b. An act or omission committed in providing or failing to provide "incidental medical services", first aid or "Good Samaritan services" to a person, unless you are in the business or occupation of providing professional health care services.

2. The following replaces the last paragraph of Paragraph **2.a.(1)** of **SECTION II – WHO IS AN INSURED**:

Unless you are in the business or occupation of providing professional health care services, Paragraphs **(1)(a), (b), (c)** and **(d)** above do not apply to "bodily injury" arising out of providing or failing to provide:

(a) "Incidental medical services" by any of your "employees" who is a nurse, nurse assistant, emergency medical technician or paramedic; or

(b) First aid or "Good Samaritan services" by any of your "employees" or "volunteer workers", other than an employed or volunteer doctor. Any such "employees" or "volunteer workers" providing or failing to provide first aid or "Good Samaritan services" during their work hours for you will be deemed to be acting within the scope of their employment by you or performing duties related to the conduct of your business.

3. The following replaces the last sentence of Paragraph **5.** of **SECTION III – LIMITS OF INSURANCE**:

For the purposes of determining the applicable Each Occurrence Limit, all related acts or omissions committed in providing or failing to provide "incidental medical services", first aid or "Good Samaritan services" to any one person will be deemed to be one "occurrence".

4. The following exclusion is added to Paragraph **2., Exclusions**, of **SECTION I – COVERAGES – COVERAGE A – BODILY INJURY AND PROPERTY DAMAGE LIABILITY**:

Sale Of Pharmaceuticals

"Bodily injury" or "property damage" arising out of the violation of a penal statute or ordinance relating to the sale of

pharmaceuticals committed by, or with the knowledge or consent of, the insured.

5. The following is added to the **DEFINITIONS** Section:

"Incidental medical services" means:

a. Medical, surgical, dental, laboratory, x-ray or nursing service or treatment, advice or instruction, or the related furnishing of food or beverages; or

b. The furnishing or dispensing of drugs or medical, dental, or surgical supplies or appliances.

6. The following is added to Paragraph **4.b., Excess Insurance**, of **SECTION IV – COMMERCIAL GENERAL LIABILITY CONDITIONS**:

This insurance is excess over any valid and collectible other insurance, whether primary, excess, contingent or on any other basis, that is available to any of your "employees" for "bodily injury" that arises out of providing or failing to provide "incidental medical services" to any person to the extent not subject to Paragraph **2.a.(1)** of Section II – Who Is An Insured.

D. BLANKET WAIVER OF SUBROGATION

The following is added to Paragraph **8., Transfer Of Rights Of Recovery Against Others To Us**, of **SECTION IV – COMMERCIAL GENERAL LIABILITY CONDITIONS**:

If the insured has agreed in a contract or agreement to waive that insured's right of recovery against any person or organization, we waive our right of recovery against such person or organization, but only for payments we make because of:

a. "Bodily injury" or "property damage" that occurs; or

b. "Personal and advertising injury" caused by an offense that is committed;

subsequent to the execution of the contract or agreement.

E. CONTRACTUAL LIABILITY – RAILROADS

1. The following replaces Paragraph **c.** of the definition of "insured contract" in the **DEFINITIONS** Section:

c. Any easement or license agreement;

2. Paragraph f.(1) of the definition of "insured contract" in the **DEFINITIONS** Section is deleted.

F. DAMAGE TO PREMISES RENTED TO YOU

The following replaces the definition of "premises damage" in the **DEFINITIONS** Section:

"Premises damage" means "property damage" to:

- a. Any premises while rented to you or temporarily occupied by you with permission of the owner; or
- b. The contents of any premises while such premises is rented to you, if you rent such premises for a period of seven or fewer consecutive days.

COMMERCIAL GENERAL LIABILITY COVERAGE FORM

Various provisions in this policy restrict coverage. Read the entire policy carefully to determine rights, duties and what is and is not covered.

Throughout this policy the words "you" and "your" refer to the Named Insured shown in the Declarations, and any other person or organization qualifying as a Named Insured under this policy. The words "we", "us" and "our" refer to the company providing this insurance.

The word "insured" means any person or organization qualifying as such under Section II – Who Is An Insured.

Other words and phrases that appear in quotation marks have special meaning. Refer to Section V – Definitions.

SECTION I – COVERAGES

COVERAGE A – BODILY INJURY AND PROPERTY DAMAGE LIABILITY

1. Insuring Agreement

- a. We will pay those sums that the insured becomes legally obligated to pay as damages because of "bodily injury" or "property damage" to which this insurance applies. We will have the right and duty to defend the insured against any "suit" seeking those damages. However, we will have no duty to defend the insured against any "suit" seeking damages for "bodily injury" or "property damage" to which this insurance does not apply. We may, at our discretion, investigate any "occurrence" and settle any claim or "suit" that may result. But:

- (1) The amount we will pay for damages is limited as described in Section III – Limits Of Insurance; and
- (2) Our right and duty to defend end when we have used up the applicable limit of insurance in the payment of judgments or settlements under Coverages A or B or medical expenses under Coverage C.

No other obligation or liability to pay sums or perform acts or services is covered unless explicitly provided for under Supplementary Payments.

- b. This insurance applies to "bodily injury" and "property damage" only if:

- (1) The "bodily injury" or "property damage" is caused by an "occurrence" that takes place in the "coverage territory";
- (2) The "bodily injury" or "property damage" occurs during the policy period; and
- (3) Prior to the policy period, no insured listed under Paragraph 1. of Section II – Who Is An Insured and no "employee" authorized by you to give or receive notice of an "occurrence" or claim knew that the "bodily injury" or "property damage" had occurred, in whole or in part. If such a listed insured or authorized "employee" knew, prior to the policy period, that the "bodily injury" or "property damage" occurred, then any continuation, change or resumption of such "bodily injury" or "property damage" during or after the policy period will be deemed to have been known prior to the policy period.

- c. "Bodily injury" or "property damage" which occurs during the policy period and was not, prior to the policy period, known to have occurred by any insured listed under Paragraph 1. of Section II – Who Is An Insured or any "employee" authorized by you to give or receive notice of an "occurrence" or claim, includes any continuation, change or resumption of that "bodily injury" or "property damage" after the end of the policy period.

- d. "Bodily injury" or "property damage" will be deemed to have been known to have occurred at the earliest time when any insured listed under Paragraph 1. of Section II – Who Is An Insured or any "employee" authorized by you to give or receive notice of an "occurrence" or claim:

- (1) Reports all, or any part, of the "bodily injury" or "property damage" to us or any other insurer;
- (2) Receives a written or verbal demand or claim for damages because of the "bodily injury" or "property damage"; or
- (3) Becomes aware by any other means that "bodily injury" or "property damage" has occurred or has begun to occur.

c. Method Of Sharing

If all of the other insurance permits contribution by equal shares, we will follow this method also. Under this approach each insurer contributes equal amounts until it has paid its applicable limit of insurance or none of the loss remains, whichever comes first.

If any of the other insurance does not permit contribution by equal shares, we will contribute by limits. Under this method, each insurer's share is based on the ratio of its applicable limit of insurance to the total applicable limits of insurance of all insurers.

d. Primary And Non-Contributory Insurance If Required By Written Contract

If you specifically agree in a written contract or agreement that the insurance afforded to an insured under this Coverage Part must apply on a primary basis, or a primary and non-contributory basis, this insurance is primary to other insurance that is available to such insured which covers such insured as a named insured, and we will not share with that other insurance, provided that:

- (1) The "bodily injury" or "property damage" for which coverage is sought occurs; and
- (2) The "personal and advertising injury" for which coverage is sought is caused by an offense that is committed;

subsequent to the signing of that contract or agreement by you.

5. Premium Audit

- a. We will compute all premiums for this Coverage Part in accordance with our rules and rates.
- b. Premium shown in this Coverage Part as advance premium is a deposit premium only. At the close of each audit period we will compute the earned premium for that period and send notice to the first Named Insured. The due date for audit and retrospective premiums is the date shown as the due date on the bill. If the sum of the advance and audit premiums paid for the policy period is greater than the earned premium, we will return the excess to the first Named Insured.
- c. The first Named Insured must keep records of the information we need for premium computation, and send us copies at such times as we may request.

6. Representations

By accepting this policy, you agree:

- a. The statements in the Declarations are accurate and complete;
- b. Those statements are based upon representations you made to us; and
- c. We have issued this policy in reliance upon your representations.

The unintentional omission of, or unintentional error in, any information provided by you which we relied upon in issuing this policy will not prejudice your rights under this insurance. However, this provision does not affect our right to collect additional premium or to exercise our rights of cancellation or nonrenewal in accordance with applicable insurance laws or regulations.

7. Separation Of Insureds

Except with respect to the Limits of Insurance, and any rights or duties specifically assigned in this Coverage Part to the first Named Insured, this insurance applies:

- a. As if each Named Insured were the only Named Insured; and
- b. Separately to each insured against whom claim is made or "suit" is brought.

8. Transfer Of Rights Of Recovery Against Others To Us

If the insured has rights to recover all or part of any payment we have made under this Coverage Part, those rights are transferred to us. The insured must do nothing after loss to impair them. At our request, the insured will bring "suit" or transfer those rights to us and help us enforce them.

9. When We Do Not Renew

If we decide not to renew this Coverage Part, we will mail or deliver to the first Named Insured shown in the Declarations written notice of the nonrenewal not less than 30 days before the expiration date. If notice is mailed, proof of mailing will be sufficient proof of notice.

SECTION V – DEFINITIONS

- 1. "Advertisement" means a notice that is broadcast or published to the general public or specific market segments about your goods, products or services for the purpose of attracting customers or supporters. For the purposes of this definition:
 - a. Notices that are published include material placed on the Internet or on similar electronic means of communication; and
 - b. Regarding websites, only that part of a website that is about your goods, products or services for the purposes of attracting customers or supporters is considered an advertisement.



WORKERS COMPENSATION
AND
EMPLOYERS LIABILITY POLICY

ENDORSEMENT WC 99 03 76 (A) -

POLICY NUMBER: UB-2X937955-23-26-G

**WAIVER OF OUR RIGHT TO RECOVER FROM OTHERS
ENDORSEMENT – CALIFORNIA
(BLANKET WAIVER)**

We have the right to recover our payments from anyone liable for an injury covered by this policy. We will not enforce our right against the person or organization named in the Schedule.

The additional premium for this endorsement shall be _____ % of the California workers' compensation premium.

Schedule

Person or Organization

Job Description

As required by written contract

This endorsement changes the policy to which it is attached and is effective on the date issued unless otherwise stated.

(The information below is required only when this endorsement is issued subsequent to preparation of the policy.)

Endorsement Effective Insured
10/01/2023

Policy No. UB-2X937955-23-26-G

Endorsement No.
Premium

Insurance Company
Travelers Property Casualty Company

Countersigned by _____

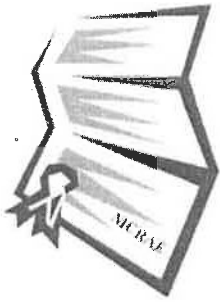

McRAE ASSOCIATES INSURANCE SERVICES

09/28/2023

To whom this may concern,

Please be advised that if we get notified by any of the insurance companies listed on the certificate that the insured, CT & T Concrete Paving, Inc. will be receiving a notice of cancellation for any of the below reasons a written notice will be mailed or delivered to you.

- 1) 10 days before the effective date of cancellation if they cancel for non-payment of premium or
- 2) 30 days' notice of cancellation will state the effective date of cancellation. The policy will end on that date.

If you have any questions or concerns please feel free to contact our office.

Thank you,

Patrick McRae

License No 0637431

Main Office: 1265 N. Manassero, Suite 303 Anaheim Hills, CA 92807 (714) 779-6999 Fax: (714) 779-6903 E-mail: p.mcrae@sbcglobal.net