

RECORDING REQUESTED BY: CITY CLERK WHEN RECORDED RETURN TO: City Clerk City of Beaumont 550 E. 6th Street Beaumont, CA 92223	 SPACE ABOVE THIS LINE FOR RECORDER'S USE
--	--

CITY OF BEAUMONT
SUBDIVISION IMPROVEMENT AGREEMENT
TRACT or PARCEL NO. 31470-6

DATE OF AGREEMENT: <u>February 13, 2024</u>		
NAME OF SUBDIVIDER: <u>Tri Pointe Homes IE-SD, Inc</u> , a <u>California Corporation</u> . (hereinafter referred to as "Subdivider").		
NAME/NUMBER OF DEVELOPMENT: <u>31470-6</u> subdivision consisting of <u>125</u> residential lots, _____, originally approved on _____, and Tentative Tract/Parcel <u>31470-6</u> ("Tract/Parcel" or "Tentative Tract/Parcel Map"), originally approved on: <u>April 3, 2019</u> .		
FINAL TRACT/PARCEL MAP <u>31470-6</u> APPROVED ON <u>April 3, 2019</u> RECORDED ON <u>April 3, 2019</u> AS INSTRUMENT NUMBER <u>2019-0111844</u> ("Final Tract Map/Final Parcel Map").		
PROPERTY SUBJECT TO AGREEMENT: The real property which is the subject of this Agreement is located in the City of Beaumont, County of Riverside and is described in Exhibit "A" attached hereto and incorporated herein (hereinafter the "Property").		
EST. TOTAL COST OF PUBLIC IMPROVEMENTS: \$ <u>152,145.00</u> (see Exhibit "B")	EST. TOTAL COST OF PRIVATE IMPROVEMENTS: \$ _____ (see Exhibit "B")	EST. TOTAL COST OF MONUMENTATION: \$ _____ (see Exhibit "B")
BOND NUMBERS: <u>PB03010409858</u>		
LETTER OF CREDIT NUMBERS: _____		
FINANCIAL INSTITUTION: _____		

THIS SUBDIVISION IMPROVEMENT AGREEMENT (“Agreement”) is made and entered into by and between the City of Beaumont, a California municipal corporation (hereinafter referred to as “City”), and Tri Pointe Homes IE-SD, Inc, a California Corporation, (hereinafter referred to as “Subdivider”). City and Subdivider are sometimes referred to hereinafter individually as a “Party”, and collectively as the “Parties”.

RECITALS

A. Subdivider is the owner of certain real property located in the City of Beaumont legally described on Exhibit “A” attached hereto and incorporated and made part of this Agreement by this reference (the “Property”).

B. The conditions of approval of the above referenced Tentative Tract Map and any related entitlements, which are hereby incorporated herein by this reference, require that prior to the issuance of building permits, the Subdivider and the City shall enter into a subdivision improvement agreement, secured with sufficient security, as a guarantee of the construction and completion of all public and private improvements and land development work required by said conditions of approval and by the City subdivision laws and codes.

D. In consideration of the approval of a final map by the City Council, Subdivider desires to enter into this Agreement, whereby Subdivider promises to install and complete, at Subdivider’s own expense, all the public improvement work required by City in connection with the proposed subdivisoion. Subdivider has secured this Agreement by improvement security required by the Subdivision Laws.

E. Improvement Plans (the “Plans”) for the construction, installation, and completion of the public and private improvements are being or have been prepared by Subdivider and will be subject to approval by the Director of Engineering/Public Works (“City Engineer”). The City has adopted standards (hereinafter “Standards”) for the construction and installation of improvements within the City, and the Plans will be prepared in conformance with the Standards in effect on the date of the approval of the Application. The Plans will be on file in the Office of the City Engineer and are incorporated into this Agreement by this reference as if set forth fully herein. All references in this Agreement to the Plans shall be deemed to include reference to any specifications for all of the improvements as approved by the City Engineer.

F. An estimate of the cost for construction of the public and private improvements and performing the land development work according to the Plans has been made and approved by the City Engineer. The estimated cost of these improvements is set forth on Page One (1) of this Agreement, and the basis for the estimate is attached hereto as Exhibit “B” and incorporated and made part of this Agreement by this reference. The amounts of the Improvement Securities required to be posted with this Agreement are also based upon the estimate in Exhibit “B”.

G. For the purposes of this Agreement, the term "Public Improvements" means all those improvements within the Tract/Parcel intended for transfer or conveyance to the City or other public agency. The estimated cost of their construction is included in the above estimate included herein as Exhibit "B".

NOW, THEREFORE, in consideration of the issuance of the Final Tract map, Subdivider and City hereby agree as follows:

1. Subdivider's Obligation to Construct Improvements.

(a) In constructing and installing the improvements, Subdivider shall comply with all of the requirements and conditions of approval of in the Tentative Tract Map, related entitlements as well as the provisions of the Municipal Code and Subdivision Laws.

(b) Subdivider shall complete, at its own expense, all the public and private improvements and related work on the Development, as required by the conditions of approval of the Tentative Map and related entitlements in conformance with the approved Plans and City Standards, including without limitation, those improvements set forth in Exhibit "B" (hereinafter collectively the "Improvements") within twenty-four (24) months of the date of this Agreement, unless a time extension is granted by the City as authorized by Section 20 of this Agreement.

(c) Notwithstanding the time limits specified in Section 1(b) above, no single family dwelling unit or group of units shall be given final inspection and clearance for occupancy by City unless the private and public streets providing access to and fronting such units are completed, the final lifts of pavement on the streets are in place, and all wet and dry utility services (e.g. sewer, water, electrical power, telephone, gas, etc.) to such units are in place and are operational.

(d) Subdivider shall furnish the necessary materials for completion of the Improvements in conformity with the Plans and City Standards.

(e) Subdivider shall acquire and dedicate, or pay the cost of acquisition by the City, of all rights-of-way, easements and other interests in real property required for construction or installation of the Improvements, free and clear of all liens and encumbrances. Subdivider's obligations relating to acquisition by City of off-site rights-of-way, easements and other interests in real property shall be subject to a separate agreement between Subdivider and City. Subdivider shall also be responsible for obtaining any public or private drainage easements or authorizations therefor to accommodate the Development.

(f) Subdivider shall furnish and install all monuments, stakes and property corners on the lots and streets in the Property as specified on the final recorded tract maps for the Development in accordance with the provisions of the Subdivision Laws, and shall submit centerline tie sheets to City, within thirty (30) days after completion of the Improvements, or as specified in any separate monument agreement with the City, but in any event prior to their acceptance by the City.

2. Improvement Securities.

(a) Subdivider agrees to secure this Agreement with good and sufficient improvement securities in a form approved by the City Attorney (referred collectively hereinafter as "Improvement Securities" and individually as "Improvement Security") to guarantee the construction and completion of all the improvements in the Development. All such improvement securities shall be posted with the City prior to the City's final building inspection and issuance of a Certificate of Occupancy for any single family dwelling constructed by Subdivider, its agents, assigns or contractors, on any lot within the Development, as described in Exhibit "A". Said securities are estimated at this time in Exhibit "B" to be in the following amounts, and shall be for the purposes described as follows:

(i) _____ and 00/100 DOLLARS (\$XXX,XXX.XX) to ensure faithful performance of the construction and installation of the public and private Improvements required by this Agreement ("Performance Security"), which amount is 100% of the estimated cost of the Improvements as set forth in Exhibit "B"; and

(ii) _____ and 00/100 DOLLARS (\$XXX,XXX.XX) to secure payment to any contractor, subcontractor, persons renting equipment or furnishing labor materials for the Improvements required to be constructed or installed pursuant to this Agreement ("Labor & Materials Security"), which amount is one-hundred percent (100%) of the estimated cost of the Improvements; and

(iii) _____ and 00/100 DOLLARS (\$ XX,XXX.XX) in the form of a Warranty Bond or cash deposit with the City to guarantee or warranty the Improvement work done pursuant to this Agreement for a period of one (1) year following acceptance/certification thereof by City, against any defective work or labor done or defective materials furnished ("Warranty Security"). The Warranty Security is 10% of the estimated cost of the Performance Security amount described above, and such Warranty Security must be provided by Subdivider to City prior to the City's release of any bonds or Improvement Securities filed with this Agreement.

(iv) _____ and 00/100 Dollars (\$X,XXX.XX) in the form of a cash deposit, which is 100% of the estimated cost of setting all final subdivision monuments, boundary corners, front and rear lot corners and centerline ties not previously set or submitted on the lots and streets within the Property as described in Exhibit "A", and for the preparation and recordation of any related Certificate of Correction, as required by Section 66469 of the State Subdivision Map Act.

(b) The Improvement Securities required by this Agreement shall be kept on file with the City Clerk. If surety bonds are used, they must be issued by a surety company currently admitted to transact surety insurance business in California by the California Department of Insurance, with a Best's Insurance Guide rating of no less than A-. The terms of any documents evidencing such Improvement Securities as set forth in this Section 2 or

2. Improvement Securities.

(a) Subdivider agrees to secure this Agreement with good and sufficient improvement securities in a form approved by the City Attorney (referred collectively hereinafter as "Improvement Securities" and individually as "Improvement Security") to guarantee the construction and completion of all the improvements in the Development. All such improvement securities shall be posted with the City prior to the City's final building inspection and issuance of a Certificate of Occupancy for any single family dwelling constructed by Subdivider, its agents, assigns or contractors, on any lot within the Development, as described in Exhibit "A". Said securities are estimated at this time in Exhibit "B" to be in the following amounts, and shall be for the purposes described as follows:

(i) One Hundred Fifty Two Thousand One Hundred Forty Five and 00/100 DOLLARS (\$XXX,XXX.XX) to ensure faithful performance of the construction and installation of the public and private Improvements required by this Agreement ("Performance Security"), which amount is 100% of the estimated cost of the Improvements as set forth in Exhibit "B"; and

(ii) One Hundred Fifty Two Thousand One Hundred Forty Five and 00/100 DOLLARS (\$XXX,XXX.XX) to secure payment to any contractor, subcontractor, persons renting equipment or furnishing labor materials for the Improvements required to be constructed or installed pursuant to this Agreement ("Labor & Materials Security"), which amount is one-hundred percent (100%) of the estimated cost of the Improvements; and

(iii) _____ and 00/100 DOLLARS (\$ XX,XXX.XX) in the form of a Warranty Bond or cash deposit with the City to guarantee or warranty the Improvement work done pursuant to this Agreement for a period of one (1) year following acceptance/certification thereof by City, against any defective work or labor done or defective materials furnished ("Warranty Security"). The Warranty Security is 10% of the estimated cost of the Performance Security amount described above, and such Warranty Security must be provided by Subdivider to City prior to the City's release of any bonds or Improvement Securities filed with this Agreement.

(iv) _____ and 00/100 Dollars (\$X,XXX.XX) in the form of a cash deposit, which is 100% of the estimated cost of setting all final subdivision monuments, boundary corners, front and rear lot corners and centerline ties not previously set or submitted on the lots and streets within the Property as described in Exhibit "A", and for the preparation and recordation of any related Certificate of Correction, as required by Section 66469 of the State Subdivision Map Act.

(b) The Improvement Securities required by this Agreement shall be kept on file with the City Clerk. If surety bonds are used, they must be issued by a surety company currently admitted to transact surety insurance business in California by the California Department of Insurance, with a Best's Insurance Guide rating of no less than A-. The terms of any documents evidencing such Improvement Securities as set forth in this Section 2 or

referenced on Page One (1) of this Agreement, are incorporated into this Agreement by this reference as if set forth fully herein. If any Improvement Security is replaced by another type or kind of approved Improvement Security, subject to the approval of the form thereof by the City Attorney, the replacement shall be filed with City Clerk and, upon filing, shall be deemed to have been made a part of and incorporated into this Agreement. Upon filing of a satisfactory replacement Improvement Security with the City Clerk, the former Improvement Security shall be released.

(c) Subdivider agrees to keep its Improvement Securities in full force and effect until they are reduced or released by City. If any Improvement Security provided by Subdivider is cancelled or terminated for any reason by the action of a surety, financial institution or other party, it shall be the responsibility of the Subdivider to immediately, upon written notice from City, provide a substitute Improvement Security which conforms to all the requirements of this Section 2 in the same amount or amounts.

(d) Any additions, changes, alterations, or modifications of this Agreement or to the Plans, Specifications and Improvements referred to herein, including any extension of time within which the work hereunder may be completed, shall not release or exonerate any surety or sureties on the Improvement Security given in connection with this Agreement.

3. Alterations to Improvement Plans; Modification of City Standards.

(a) Any changes, alterations or additions to the Plans or to the Improvements, not exceeding 10% of the original estimated cost of the Improvements, which are mutually agreed upon by City and Subdivider, shall not require Subdivider to increase any Improvement Securities provided under this Agreement. In the event such changes, alterations, or additions exceed 10% of the original estimated cost of the Improvements, Subdivider shall provide additional Performance Security as required by Section 2 of this Agreement for 100% of the total estimated cost of the Improvements as changed, altered, or amended, minus any completed partial releases allowed by Section 7 of this Agreement. Subdivider shall also provide additional Labor & Materials Security as required by Section 2 of this Agreement for 50 % of the total estimated cost of the Improvements as changed, altered, or amended.

(b) Subdivider shall construct all Improvements in a good and workman like manner and in accordance with the City Standards in effect as of the date of the Approval Action specified on Page One (1) hereof. The City reserves the right to modify the Standards applicable to the Subdivision and this Agreement, when necessary to protect the public safety or welfare or to comply with applicable State or Federal law or City zoning ordinances. If Subdivider requests and is granted an extension of time for completion of the Improvements, the City may apply the Standards in effect at the time the extension is granted.

4. Modification of Drainage Plan. Subdivider agrees that if during the course of construction and installation of Improvements it shall be determined by the City Engineer that revision of the

drainage plan is necessary in the public interest, it will undertake such design and construction changes as may be reasonable and as are indicated by the City Engineer and approved by City. Said changes, if any, shall be confined to the Property.

5. **Reserved.**

6. **Inspections; Final Acceptance and Certification of Improvements.**

(a) Subdivider shall at all times maintain proper facilities and safe access for inspection of the Improvements by City inspectors and to the shops wherein any work is in preparation.

(b) Upon completion of the Improvements covered in this Agreement, the Subdivider shall request a final inspection by the City Engineer or his/her authorized representative. Following receipt of such request, the City Engineer shall inspect the Improvements, make certain determinations and take certain actions as follows:

(i) If the City Engineer, or his/her authorized representative, determines that the Public Improvements requiring acceptance by another public agency have been completed in accordance with this Agreement, then the City Engineer shall request said agency to make a final inspection of such improvements and certify to the City that such improvements have been completed and installed to the satisfaction of said agency. Upon receipt of such certification, the City Engineer may release or reduce the securities held for such improvements. Any certification and/or acceptance of the Public Improvements shall not constitute a waiver of any defects by City.

(ii) For Improvements not requiring dedication to or acceptance by the a public agency (the "Private Improvements"), the City Engineer or his/her authorized representative shall inspect such improvements, and/or shall have the discretion to accept a certification from Subdivider's registered civil engineer stating that the Private Improvements have been completed in accordance with the approved Plans, City Standards and the Tentative Map. If the City Engineer, or his/her authorized representative, makes a finding, based on his/her own inspection (and/or any certification submitted by Subdivider's registered civil engineer) that the Private Improvements have been installed and constructed in accordance with the approved Plans, City Standards and the Tentative Map, the City Engineer shall recommend certification of the completion of the Private Improvements by placing an item on the next most convenient City Council agenda requesting certification and authorization to release the Improvement Securities. Said determination by the City Engineer and agendization of the certification and release shall not be unreasonably withheld or delayed.

(c) Subdivider shall bear all costs of inspection and certification of the Improvements.

7. Release of Improvement Securities.

(a) The Performance Security shall be fully released only upon the final completion and certification of all Private Improvements and Public Improvements. Partial releases may be permitted subject to the provisions of Subsections (a)(i) and (a)(ii) hereof. Upon final completion of the Public and Private Improvements under this Agreement, and after City Council acceptance/certification, the City shall file a Notice of Completion in accordance with the California Civil Code.

(i) The City Engineer may release a portion of the Performance Security, as work on the Improvements progresses, upon written application thereof by the Subdivider; provided, however, that no such release shall be considered by City for an amount less the cost estimate of the remaining work does not exceed twenty percent (20%) or less of the estimate of the total amount of work to be done as shown in Exhibit "B". Upon approval of a partial release or the reduction of Performance Security, the City shall not reduce such Performance Security to an amount less than two hundred percent (200%) of the value of the work remaining to be done. City and Subdivider agree that not more than two requests for reduction or partial release of Performance Security shall be considered between the start of construction and the completion and acceptance/certification of the Improvements by the City.

(ii) In no event shall the City Engineer authorize a release or reduction of the Performance Security which would reduce such security to an amount below that required to guarantee the completion of the Improvements and any other obligations imposed upon Subdivider by this Agreement.

(iii) No partial reduction or release of the Performance Security shall constitute or be construed as the City's acceptance or certification of any Improvements or related work. Such partial reductions or releases (if any) will merely reflect that a certain portion of the required work has been done.

(b) The Labor & Materials Security shall, ninety (90) days after the City's recordation of the Notice of Completion described in Subsection 7(a), be reduced to an amount equal to the total claimed by all claimants for whom liens have been filed and of which notice has been given to City, plus an amount reasonably determined by the City Engineer to be required to assure the performance of any other obligations secured by the Labor & Materials Security and to cover related legal costs. The balance shall be released upon the settlement of all claims and obligations for which the Labor & Materials Security was given. If no claims or liens have been filed and no notice has been given to City within said ninety (90) day period, then the Labor & Materials Security shall be released in full.

(c) The Warranty Security shall not be released until after the expiration of the one-year (1-year) warranty period and until any claims filed during the warranty period have been settled. As provided in Section 11, below, the warranty period shall not commence until final acceptance/certification of the Improvements and related work by the City Council.

(d) The Monumentation Security may be released in full by the City Engineer in accordance with the terms of the separate monument agreement with the City, or if there is none, upon submittal of the following:

(i) a written certification from the professional engineer or surveyor responsible for setting the monuments stating that all the final monuments for the Subdivision have been set in accordance with the Professional Land Surveyors Act and the Subdivision Map Act, and that the professional engineer or surveyor has been paid in full by Subdivider for such services; and

(ii) centerline tie sheets prepared in a manner acceptable to the City Engineer showing the locations of centerline monuments in existing public or private streets; and

(iii) any Record of Survey required by this Agreement has been filed with the County of Riverside and recorded.

(e) The City may retain from any Improvement Securities released an amount sufficient to cover costs and reasonable expenses and fees, including reasonable attorneys' fees.

8. Injury to Public Improvements, Public Property or Public Utilities Facilities.

Subdivider shall replace or repair or cause the repair or replacement of any and all public or private improvements, public utilities facilities and survey or subdivision monuments which are destroyed or damaged as a result of any work under this Agreement. Subdivider shall bear the entire cost of replacement or repairs of any and all public or private improvements or utility property damaged or destroyed by reason of any work done under this Agreement, whether such property is owned by the United States or any agency thereof, or the State of California, or any agency or political subdivision thereof, or by the City or any public or private utility corporation or by any combination of such owners. Any repair or replacement shall be made to the reasonable satisfaction, and subject to the approval of the City Engineer and the owner of any such public or private improvement.

9. Permits. Subdivider shall, at Subdivider's expense, obtain all necessary permits and licenses for the construction and installation of the Improvements, give all necessary notices and pay all fees and taxes required by law.

10. Notice of Breach/Default of Subdivider.

(a) Default of Subdivider shall include, but not be limited to: (1) Subdivider's failure to timely complete construction of the Improvements; (2) Subdivider's unwarranted failure to timely cure any defect in the Improvements; (3) Subdivider's failure to perform substantial construction work for a period of twenty (20) consecutive calendar days after commencement of the work; (4) Subdivider's insolvency, appointment of a receiver, or the filing of any petition in bankruptcy either voluntary or involuntary which Subdivider fails to discharge within thirty (30) days; (5) the commencement of a foreclosure action against the

Property or a portion thereof, or any conveyance in lieu or in avoidance of foreclosure; (6) Subdivider's failure to keep the Improvement Securities in full force and effect; (7) Subdivider's failure to notify the City of any sale, transfer or other disposition of the Property to a purported new Subdivider; (8) Subdivider's failure to maintain insurance; or (9) the failure of Subdivider or Subdivider's contractors, subcontractors, agents or employees to comply with any other terms and provisions of this Agreement.

(b) In the event of any such default, the City Engineer or the City Council may serve written notice to Subdivider specifying in reasonable detail the nature of the default. Subdivider shall have thirty (30) days from receipt of said notice to cure the default; provided that, if the default is not reasonably susceptible to being cured within said thirty (30) days, Subdivider shall have a reasonable period of time to cure the default so long as Subdivider commences to cure the default within said thirty (30) days and diligently prosecutes the cure to completion.

(c) If following service of such written notice of default, Subdivider fails to cure or commence curing the default to the satisfaction of City within the cure period specified in Subsection 10(b), above, the City Engineer or the City Council may serve notice of Subdivider's default upon Subdivider and where applicable Subdivider's surety, or the holder(s) of any other Improvement Securities, in accordance with the notice provisions set forth in Section 22 of this Agreement.

(d) In the event of service of the notice of default specified in Subsection 10(c), above, Subdivider's surety shall have the duty to take over and complete the Improvements and related work required under this Agreement; provided; however, that if the surety, within twenty (20) days after the serving upon it of such notice of default, does not give the City written notice of its intention to take over the construction of said Improvements or does not, within ten (10) days after giving City notice of such election, commence to complete the Improvements, City may take over the work and prosecute the Improvements to completion, by contract or by any other method City may deem advisable, for the account and at the expense of Subdivider, and Subdivider's surety shall be liable to City for any costs or damages occasioned City thereby; and, in such event, City, without liability for so doing, may take possession of, and utilize in completing the Improvements, such materials, appliances, plant and other property belonging to Subdivider as may be on the site of the work and necessary for the completion of same.

(e) The City reserves to itself all remedies available to it at law or in equity for Subdivider's default under this Agreement. The City shall have the right, subject to this Section, to draw upon or utilize the appropriate Improvement Securities to mitigate City's damages in event of default by Subdivider. The right of City to draw upon or utilize the Improvement Securities is additional to and not in lieu of any other remedy available to City. It is specifically recognized that the estimated costs and amounts of Improvement Securities may not reflect the actual cost of construction or installation of the Improvements, and therefore, City's damages for Subdivider's default shall be measured by the actual cost of completing the required Improvements. The sums provided by the

Improvement Securities may be used by City for the completion of the Improvements in accordance with the Plans.

(f) Failure of Subdivider to comply with the terms of this Agreement, including but not limited to, construction of all the Improvements as set forth herein and as required by the Tentative Map, shall constitute Subdivider's consent to: (1) the filing by City of a notice of violation against all of the lots in the Subdivision; (2) withholding of Building permits, utility connections and/or Certificates of Occupancy. The remedies provided by this Subsection (f) are in addition to and not in lieu of any other remedies available to City at law or in equity. Subdivider agrees that the choice of remedy or remedies for Subdivider's default or breach shall be in the sole discretion of City.

(g) In the event that Subdivider fails to perform any obligation hereunder, Subdivider agrees to pay all costs and expenses incurred by City in securing performances of such obligations, including costs of suit and reasonable attorney's fees.

(h) The failure of City to take an enforcement action with respect to a default, or to declare a default or breach, shall not be construed as a waiver of that default or breach, or of any subsequent default or breach of Subdivider. Any failure by the City to enforce any provision of this Agreement shall not be construed as a waiver of the right to compel enforcement of such provision(s) and further shall not act to release any surety from its obligations under this Agreement.

11. Warranty.

(a) For a period of one (1) year after final acceptance/certification by the City Council of the Improvements, Subdivider shall guarantee or warranty all the Improvements against any defective work or labor done or defective materials furnished. If within the warranty period any work relating to the Improvements or any part of thereof furnished, installed, constructed or caused to be done, furnished, installed or constructed by Subdivider fails to fulfill any of the requirements of this Agreement or the Plans, Subdivider shall without delay and without any cost to City, commence to repair or replace or reconstruct any defective or otherwise unsatisfactory part or parts of the work or structure within thirty (30) days of receiving written notice from City of the defect and diligently prosecute the repair or replacement work to completion.

(b) Should Subdivider fail to act promptly or in accordance with the repair/replacement requirements set forth herein, Subdivider hereby authorizes City, at City's option, to perform the repair/replacement work twenty (20) days after mailing written notice to Subdivider and to Subdivider's surety, and Subdivider agrees to pay City for the cost of such work.

(c) Should the City determine that an emergency or a threat to the public safety and welfare exists from the condition of the Improvements which require repairs, replacements or remedial measures to be made before Subdivider can be notified, City may, in its sole

discretion, make the necessary repairs or replacements or perform the necessary work and Subdivider shall pay to City the cost of such repairs.

12. Subdivider Not Agent of City. Neither Subdivider nor any of Subdivider's agents, officers, employees, or contractors are or shall be considered to be agents of City in connection with the performance of Subdivider's obligations under this Agreement.

13. Injury to Improvement Work; Risk of Loss. Until such time as the Public Improvements are accepted by City, Subdivider shall be responsible for and bear the risk of loss to any of the Public Improvements constructed or installed and shall be responsible for the care, maintenance of and any damage to such Public Improvements. Neither City, nor any of its agents, officers or employees shall be liable or responsible for any accident, loss or damage, regardless of cause, happening or occurring to the Public Improvements specified in this Agreement prior to the completion and acceptance of the Public Improvements by City. All such risks shall be the responsibility of and are hereby assumed by Subdivider. Subdivider is responsible for and shall bear the risk of loss for all Private Improvements at all times.

14. Other Agreements. Nothing contained in this Agreement shall preclude City from expending monies pursuant to agreements concurrently or previously executed between the Parties, or from entering into agreements with other Subdividers for the apportionment of costs of water and sewer mains, or other improvements, pursuant to the provisions of City ordinances providing therefor, nor shall anything in this Agreement commit to any such apportionment.

15. Subdivider's Obligation to Warn Public During Construction. Until final acceptance/certification of the Public Improvements pursuant to Section 6(b)(i), and final certification of construction of the Private Improvements pursuant to Section 6(b)(ii), Subdivider shall give good and adequate warning to the public of each and every dangerous condition existent in said Improvements and will take all reasonable actions to protect the public from such dangerous conditions in, on or around the work site.

16. Vesting of Ownership. Upon acceptance of the Public Improvements and related work on behalf of the City, and after recordation of the Notice of Completion, ownership of the Public Improvements constructed within the Private streets in the Development shall vest in the name of the City, or applicable government agency or utility company, and any improvement constructed on any public street pursuant to this Agreement shall vest in City.

17. Indemnity/Hold Harmless.

(a) Neither the City, nor any official, officer, employee, contractor or agent thereof, shall be liable for any injury to persons or property occasioned by reason of the acts or omissions of Subdivider, its agents, subcontractors or employees in the performance of this Agreement. Subdivider hereby agrees to, and shall defend and hold harmless City, its elective and appointive boards, commissions and officers, and its agents, contractors and employees from and against any and all claims, demands, causes of action, damages, costs, expenses, actual attorneys' fees, consultant's fees, expert's fees, losses or liability, in law or in equity, of every kind and nature whatsoever arising out of or in connection with

Subdivider's operations, or any subcontractor's operations, to be performed under this Agreement for Subdivider's or subcontractor's tort negligence including active or passive, or strict negligence, including but not limited to personal injury including, but not limited to bodily injury, emotional injury, sickness or disease, or death to persons and/or damage to property of anyone, including loss of use thereof, caused or alleged to be caused by any act or omission of Subdivider or any subcontractor, or anyone directly or indirectly employed by any of them or anyone for the full period of time allowed by law, with the exception of the sole negligence or willful misconduct of City.

(b) Subdivider's indemnity, defense and hold harmless obligations under this Section 17 are not conditioned or dependent upon whether City, or its elective and appointive boards, commissions and officers, or its agents, contractors and employees, prepared, supplied or reviewed any Plans or related specifications in connection with the Improvements, or whether City or Subdivider has insurance or other indemnification covering any of these matters.

(c) Subdivider's obligation to indemnify, hold harmless and defend City shall extend to injuries to persons and damages to or alleged taking of property resulting from the design or construction of the Improvements. City's acceptance and/or certification of the Improvements shall not constitute an assumption by City of any responsibility or liability for any damage or alleged taking of property referenced herein. City shall not be responsible or liable for the design or construction of the Improvements constructed or installed pursuant to the Plans, unless the particular Improvement design was required by City over the written objection of Subdivider, which objection stated that the Improvement design was potentially dangerous or defective and set forth a safe and feasible alternative design. After City's acceptance/certification of the Improvements, Subdivider shall remain obligated to correct or eliminate all dangerous conditions caused by defects in design or construction; provided, however, that the Subdivider shall not be responsible for routine maintenance. Subdivider acknowledges and agrees that Subdivider shall be responsible and liable for the design and construction of the Improvements and other work done pursuant to this Agreement, and except as may be provided above, City shall not be liable for any acts or omissions in approving, reviewing, checking, correcting or modifying any Plans, or in inspecting, reviewing or approving any work or construction of Improvements. Subdivider's Improvement Securities shall not be required to secure Subdivider's obligations under this Section 17.

18. Sale or Disposition of Subdivision; Assignment.

(a) Subdivider acknowledges and agrees that sale, transfer or other disposition of the Property prior to completion of the Improvements required hereunder will not relieve Subdivider from the obligations set forth in this Agreement, and Subdivider shall be required to notify City sixty (60) days in advance of any sale or transfer of ownership of the Property or any proposed assignment of this Agreement. If Subdivider sells or otherwise transfers the Property to any other person or entity prior to final completion of the Improvements, or wishes to assign this Agreement, Subdivider may request a novation of this Agreement and a substitution of Improvement Securities by the new owner or proposed

assignee (hereinafter collectively for purposes of this Section, "Successor"). Subdivider shall be required to provide any documentation reasonably required by City to determine the appropriateness of any proposed Successor.

(b) Any proposed Successor must demonstrate to the City its ability to perform and complete the obligations of Subdivider under this Agreement, as determined by objective standards of financial capability, creditworthiness and experience required for such performance, and the City shall have the right to compel the Successor to disclose all documents, information and other material which, in City's sole reasonable discretion, may establish or tend to establish that the proposed Successor meets the standards specified herein. Following approval by City and full execution of a novation (or other such release or assignment and assumption agreement(s) entered into by Subdivider, Successor and City), posting of satisfactory Improvement Securities and submission of required insurance by Successor, City shall release or reduce the securities posted by Subdivider in accordance with the provisions of such novation and release Subdivider of its obligations under this Agreement. Nothing in the novation (or other such release or assignment and assumption agreement entered into by Subdivider, Successor and City) shall relieve Subdivider of its obligations under any other Section of this Agreement for work or Improvements performed by Subdivider prior to the novation.

19. Time of the Essence. Time is of the essence in this Agreement.

20. Time for Completion of Improvements; Extensions.

(a) Subdivider shall commence and diligently prosecute to completion construction of all the Improvements required by this Agreement. The time for completion of the Improvements as specified in Subsection 1(b) of this Agreement may be extended as permitted by City ordinance. The City Manager may grant an extension of time for such period as may be in the public interest upon the showing of the Subdivider of good cause. Any such extension granted shall be subject to the limitations and conditions set forth in Subsections 20(b) and (c), below, and shall be made by a writing executed by the in a form as approved by the City Attorney.

(b) Any such extension may be granted without notice to Subdivider's surety and shall not affect the validity of this Agreement or release the surety or sureties on any Improvement Securities given for this Agreement. However, City reserves the right to require as part of any extension amendment a written assurance from the surety acceptable to the City Attorney that the Improvement Securities required by Section 2 of this Agreement shall remain enforceable throughout the term of any extension.

(c) The City Manager shall be the sole and final judge as to whether or not good cause has been shown to entitle Subdivider to an extension. In addition, the time for completion of the Improvements shall be extended for any delay resulting from an act of City, or from an act of God, which Subdivider could not have reasonably foreseen, or by storm or inclement weather which prevents the conducting of work, or by strikes, boycotts, similar actions by employees or labor organizations, which prevent the conducting of work, and

which were not caused by or contributed to by Subdivider, provided that Subdivider provides City with written notice of the delaying event within fifteen (15) days of the commencement of the delay. In the event of such delaying event, Subdivider shall use all reasonable efforts to remedy same and resume completion of the Improvements as promptly as practicable.

(d) As a condition of granting an extension of time to complete the Improvements required by this Agreement, the City Manager may require Subdivider to furnish new or additional Improvement Securities guaranteeing performance of this Agreement as extended in an increased amount as necessary to compensate for any increase in construction costs as determined by the City Engineer.

21. Notice. All notices required by or provided for under this Agreement shall be in writing and delivered in person or sent by certified or registered mail, postage prepaid and addressed as provided in this Section. Notice shall be effective on the date it is delivered in person, or, if mailed, on the date of deposit in the United States Mail. Notices shall be addressed as follows unless a written change of address is filed with City:

Notice to City:	City of Beaumont 550 E. 6th Street Beaumont, CA 92223
Attn: City Manager	
With a Copy to:	John Pinkney, Esq. SBEMP 1800 East Tahquitz Canyon Way Palm Springs, CA 92262

Notice to Subdivider:

22. Severability. The provisions of this Agreement are severable. If any portion of this Agreement is held invalid by a court of competent jurisdiction, the remainder of the Agreement shall remain in full force and effect unless amended or modified in writing by the mutual consent of the Parties.

23. Captions. The captions of this Agreement are for convenience and reference only and shall not define, explain, modify, limit, exemplify, or aid in the interpretation, construction or meaning of any provisions of this Agreement.

24. **Insurance.**

(a) Subdivider shall, at all times during the construction of the Improvements, obtain, carry, maintain, and keep in full force and effect, at its sole cost and expense, policies of insurance of the types and in at least the minimum amounts described below:

(i) Commercial General Liability policy with a minimum combined single limit of One Million Dollars (\$1,000,000) for each occurrence and Two Million Dollars (\$2,000,000) in the aggregate for bodily injury, death, personal injury and property damage arising out of or in connection with the activities of the Subdivider and its contractors and subcontractors in performance of the work under this Agreement. Coverage shall be at least as broad as Insurance Services Office Commercial General Liability coverage (Occurrence Form CG 0001) and shall, in addition to the other coverages specified in this subsection, include coverage for independent contractors, ongoing operations, products and completed operations, contractual liability and personal and advertising injury.

(ii) Commercial Vehicle/Automotive Liability policy covering personal injury and property damage, with minimum limits of One Million Dollars (\$1,000,000) per occurrence, combined single limit, covering any vehicle utilized by Subdivider, its officers, agents, employees, subcontractors or independent contractors in performing the work required by this Agreement.

(iii) Workers' Compensation and Employer's Liability policy for all Subdivider's employees, with Workers' Compensation limits as required by State law and Employer's Liability coverage of \$1,000,000 per accident for bodily injury or disease. In case any work is sublet, Subdivider shall require any contractor or subcontractor similarly to provide Workers' Compensation and Employer's Liability Insurance for all contractor's or subcontractor's employees, unless such employees are covered by the protection afforded by Subdivider.

(1) In case any class of employees engaged in work under this Agreement at the work site(s) is not protected under any Workers' Compensation law, Subdivider shall provide and shall cause each contractor or subcontractor to provide, adequate insurance for the protection of employees not otherwise protected.

(2) Subdivider hereby indemnifies City for any damages or claims resulting from failure of either Subdivider or any contractor or subcontractor to take out or maintain such liability or Workers' Compensation insurance.

(b) Insurer Rating; Acceptability. Except as set forth otherwise herein, the policies required by this Section shall be issued by a California-admitted insurer with a rating of at least a A-; VII in the latest edition of Best's Insurance Guide. A Commercial General Liability policy issued by an insurer that is on the California Department of Insurance's List of Approved Surplus Line Insurers ("LASLI") will be acceptable, if no coverage from an

admitted insurer can be obtained by Subdivider, and further provided that such insurer maintains a Best's rating of at least "A-; X" and remains on the LASLI during the term hereof. Workers' Compensation coverage issued by the State Compensation Insurance Fund shall be acceptable if no other coverage can be obtained by Subdivider, and further provided such insurer remains admitted in California and is otherwise financially acceptable to City.

(c) Deductibles. Any deductibles or self-insured retentions must be declared in writing by Subdivider to City and subsequently approved by City prior to its execution of this Agreement and prior to commencement of any work hereunder. At City's option, Subdivider shall either reduce or eliminate the deductibles or self-insured retentions with respect to City, or Subdivider shall procure a bond guaranteeing payment of losses and expenses.

(d) Certificates and Endorsements Verification. Subdivider shall submit to the City original certificates of insurance and endorsements evidencing the coverages required by this Section. The certificates and endorsements for each insurance policy shall be signed by a person authorized by that insurer to bind coverage on its behalf. The City reserves the right to require complete, certified copies of all required insurance policies at any time and/or to require Subdivider to provide reports or status updates to evidence compliance of its contractors and subcontractors with the provisions of this Section.

(e) Required Endorsements.

(i) The Commercial General Liability and Commercial Vehicle/Automotive Liability policies are to contain or be endorsed to contain the following provisions:

(1) Additional Insureds. The City of Beaumont, its officials, officers, employees, agents and independent contractors shall be named as additional insureds with respect to liability arising out of automobiles owned, leased, hired or borrowed by or on behalf of the Subdivider; and with respect to liability arising out of work or operations performed by or on behalf of the Subdivider including materials, parts or equipment furnished in connection with such work or operations.

(2) Primary Insurance. For any claims related to this project, the Subdivider's insurance coverage shall be primary insurance as respects the City of Beaumont, its officials, officers, employees, agents and independent contractors. Any insurance or self-insurance maintained by the City of Beaumont, its officials, officers, employees, agents and independent contractors shall be excess of the Subdivider's insurance and shall not contribute with it. This endorsement is not applicable to the Commercial Vehicle/Automotive Liability Policy.

(3) Waiver of Subrogation. Endorsements waiving all rights of subrogation against the City of Beaumont, its officials, officers, employees, agents and independent contractors shall be provided.

(ii) The Workers' Compensation policy shall be endorsed to waive all rights of subrogation against the City of Beaumont, its officials, officers, employees, agents and independent contractors.

(f) Other Insurance Requirements. All policies required under this Agreement shall contain provisions stating that such policies cannot be canceled or reduced except on at least thirty (30) days prior written notice to Subdivider (ten (10) days' notice for cancellation due to non-payment). Subdivider further agrees to: (1) provide to City copies of any notices relating to cancellation or reduction of insurance within two (2) days of receipt; and (2) cause all certificates of insurance to include language indicating that the issuers or producers of such policies will endeavor to provide copies of any such notices directly to City.

(g) Commencement of Work. Subdivider shall not commence work under this Agreement until Subdivider has obtained all insurance required pursuant to this Section, and such insurance has been obtained by Subdivider and approved by City; nor shall Subdivider allow any contractor or subcontractor to commence work on the Improvements until all similar insurance required of the contractor or subcontractor has been obtained. Certificates, endorsements, and where applicable, full copies of policies shall be maintained on file with the City Clerk.

(h) Higher Limits. If Subdivider maintains higher limits than the minimums specified in this Section 25, the City requires and shall be entitled to coverage for the higher limits maintained by Subdivider. Any available insurance proceeds in excess of the specified minimum limits of insurance and coverage shall be available to the City.

25. Attorneys' Fees. In the event any action at law or in equity is brought to enforce the terms of this Agreement, the prevailing Party shall be entitled to litigation costs and reasonable attorneys' fees.

26. Incorporation of Recitals. The Recitals to this Agreement are hereby incorporated into in the terms of this Agreement.

27. Entire Agreement. This Agreement constitutes the entire agreement of the Parties and supersedes any prior written or oral agreements between them with respect to the subject matter hereof. All modifications, amendments, or waivers of the terms of this Agreement must be in writing and signed by the appropriate representatives of the Parties.

28. Governing Law; Venue. This Agreement shall be governed by and interpreted in accordance with the laws of the State of California. In the event that suit shall be brought by either Party to this contract, the Parties agree that venue shall be exclusively vested in the State courts

of the County of Riverside, California or where appropriate, in the United States District Court, Southern District of California, Riverside, California.

29. Runs with the Land; Recordation.

(a) The Parties agree that the terms and provisions set forth in this Agreement shall be deemed provisions, terms and/or covenants running with the Property in accordance with applicable law, including without limitation, California Civil Code section 1468, and shall pass to and be binding upon the heirs, successors and assigns of the Parties to this Agreement, and on any successor owner of the Property.

(b) The provisions of Subsection 29(a) notwithstanding, Subdivider shall remain jointly and severally liable with its heirs, successors, assigns or successor owners of the Property for the responsibilities and liabilities imposed by this Agreement unless a novation or assignment agreement is executed in accordance with the provisions of Section 18 of this Agreement.

(c) Upon execution, this Agreement shall be recorded in the Official Records of Riverside County, and by such recordation, it is the intention of the Parties to give notice to and bind their successors, heirs and assigns hereto.

30. Authority of Executing Parties. Each person executing this Agreement on behalf of a Party represents and warrants that such person is duly and validly authorized to do so all behalf of the entity it purports to bind and that he/she is authorized to enter into contracts on behalf of Subdivider. The undersigned, on behalf of Subdivider, binds Subdivider, its partners, successors, executors, administrators, and assigns with respect to the terms and provisions of this Agreement.

IN WITNESS WHEREOF, this Agreement is executed by the Parties hereto on the date above first written.

Subdivider:
Tri Pointe Homes IE-SD, Inc
California Corporation

Signature:  _____

City:
CITY OF BEAUMONT
a Municipal Corporation

Signature: _____
City Manager

ATTEST:

City Clerk

APPROVED AS TO FORM:

John Pinkney, City Attorney

APPROVED AS TO CONTENT:

Robert Vestal, Director Of Engineering/
Public Works

(Proper Notarization of Subdivider's Signature is required and shall be attached)

ACKNOWLEDGMENT

A notary public or other officer completing this certificate verifies only the identity of the individual who signed the document to which this certificate is attached, and not the truthfulness, accuracy, or validity of that document.

State of California
County of Riverside)

On 02/13/2024 before me, Edelmira Gonzales / Notary Public
(insert name and title of the officer)

personally appeared Matt Sauls
who proved to me on the basis of satisfactory evidence to be the person(s) whose name(s) is/are subscribed to the within instrument and acknowledged to me that he/she/they executed the same in his/her/their authorized capacity(ies), and that by his/her/their signature(s) on the instrument the person(s), or the entity upon behalf of which the person(s) acted, executed the instrument.

I certify under PENALTY OF PERJURY under the laws of the State of California that the foregoing paragraph is true and correct.

WITNESS my hand and official seal.

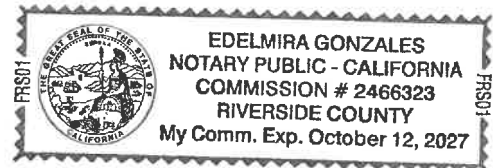

Signature Edelmira Gonzales (Seal)

PW #:
File #:

PERFORMANCE BOND

WHEREAS, the City of Beaumont, State of California, and Tri Pointe Homes IE-SD, Inc. (hereinafter designated as "Principal") have entered into Agreement To Provide Security For Improvements For Tract Map Or Parcel Map Or Plot Plan, Tract 31470-6 (PA 34) dated February 13, 2024, whereby Principal agrees to install and complete certain designated public improvements itemized and described on Tract Map, Parcel Map or Plot Plan No. Tract 31470-6 (PA 34) which is hereby incorporated herein and made a part hereof; and

WHEREAS, Principal is required under the terms of the said agreement to furnish a bond for the faithful performance of said agreement.

NOW, THEREFORE, we, the Principal and Philadelphia Indemnity Insurance Company, as Surety, are held and firmly bound unto the City of Beaumont (hereinafter called "City"), in the penal sum of *** dollars (\$ 152,145.00) lawful money of the United States, for the payment of which sum well and truly to be made, we bind ourselves, our heirs, successors, executors and administrators, jointly and severally, firmly by these presents.

One Hundred Fifty-Two Thousand One Hundred Forty-Five and no/100 Dollars

The condition of this obligation is such that if the above bounded Principal, his or its heirs, executors, administrators, successors or assigns, shall in all things stand to and abide by, and well and truly keep and perform the covenants, conditions and provisions in the said agreement and any alteration thereof made as therein provided, on his or their part to be kept and performed at the time and in the manner therein specified, and in all respects according to their true intent and meaning, and shall indemnify and save harmless the City, its officers, agents and employees as therein stipulated, then this obligation shall become null and void; otherwise it shall be and remain in full force and effect.

As part of the obligation secured hereby and in addition to the face amount specified therefor, there shall be included costs and reasonable expenses and fees, including reasonable attorney's fees, incurred by the City in successfully enforcing such obligation, all to be taxed as costs and included in any judgment therein rendered.

The Surety hereby stipulates and agrees that no change, extension of time, alteration or addition to the terms of the agreement or to the work to be performed thereunder or the specifications accompanying the same shall in any way affect its obligations on this bond, and it does hereby waive notice of any such change, extension of time, alteration or addition to the terms of the agreement or to the work or to the specifications.

[signatures on following page]

IN WITNESS WHEREOF, this instrument has been duly executed by the Principal and Surety above named, on the 12th of February, 2024.



(Seal)

(Seal)

Philadelphia Indemnity Insurance Company
SURETY

Tri Pointe Homes IE-SD, Inc.
PRINCIPAL

By: Michelle Haase

By: Matt Sauls

Name: Michelle Haase

Name: Matt Sauls

Title: Attorney-in-Fact

Title: SVP Business Operations

Address: 800 E. Colorado Blvd., 6th Floor

By: _____

Pasadena, CA 91101

Name: _____

Title: _____

Address: 1250 Corona Pointe Court, Suite 600

Corona, CA 92879

ALL SIGNATURES MUST BE ACKNOWLEDGED BEFORE A NOTARY PUBLIC

ALL- PURPOSE CERTIFICATE OF ACKNOWLEDGMENT

A notary public or other officer completing this certificate verifies only the identity of the individual who signed the document to which this certificate is attached, and not the truthfulness, accuracy, or validity of that document.

State of California }

County of Orange }

On FEB 12 2024 before me, Janina Monroe, Notary Public
(Here insert name and title of the officer)

personally appeared Michelle Haase,
who proved to me on the basis of satisfactory evidence to be the person(s) whose
name(s) is/are subscribed to the within instrument and acknowledged to me that
~~he/she/they~~ executed the same in ~~his/her/their~~ authorized capacity(~~ies~~), and that by
~~his/her/their~~ signature(s) on the instrument the person(s), or the entity upon behalf of
which the person(s) acted, executed the instrument.

I certify under PENALTY OF PERJURY under the laws of the State of California that
the foregoing paragraph is true and correct.

WITNESS my hand and official seal.

Notary Public Signature

(Notary Public Seal)



ADDITIONAL OPTIONAL INFORMATION

DESCRIPTION OF THE ATTACHED DOCUMENT

(Title or description of attached document)

(Title or description of attached document continued)

Number of Pages _____ Document Date _____

CAPACITY CLAIMED BY THE SIGNER

- Individual (s)
 Corporate Officer

(Title)

- Partner(s)
 Attorney-in-Fact
 Trustee(s)
 Other _____

INSTRUCTIONS FOR COMPLETING THIS FORM

This form complies with current California statutes regarding notary wording and, if needed, should be completed and attached to the document. Acknowledgments from other states may be completed for documents being sent to that state so long as the wording does not require the California notary to violate California notary law.

- State and County information must be the State and County where the document signer(s) personally appeared before the notary public for acknowledgment.
- Date of notarization must be the date that the signer(s) personally appeared which must also be the same date the acknowledgment is completed.
- The notary public must print his or her name as it appears within his or her commission followed by a comma and then your title (notary public).
- Print the name(s) of document signer(s) who personally appear at the time of notarization.
- Indicate the correct singular or plural forms by crossing off incorrect forms (i.e. ~~he/she/they~~ - is ~~are~~) or circling the correct forms. Failure to correctly indicate this information may lead to rejection of document recording.
- The notary seal impression must be clear and photographically reproducible. Impression must not cover text or lines. If seal impression smudges, re-seal if a sufficient area permits, otherwise complete a different acknowledgment form.
- Signature of the notary public must match the signature on file with the office of the county clerk.
 - ❖ Additional information is not required but could help to ensure this acknowledgment is not misused or attached to a different document.
 - ❖ Indicate title or type of attached document, number of pages and date.
 - ❖ Indicate the capacity claimed by the signer. If the claimed capacity is a corporate officer, indicate the title (i.e. CEO, CFO, Secretary).
- Securely attach this document to the signed document with a staple.

PHILADELPHIA INDEMNITY INSURANCE COMPANY
One Bala Plaza, Suite 100
Bala Cynwyd, PA 19004-0950

Power of Attorney

KNOW ALL PERSONS BY THESE PRESENTS: That PHILADELPHIA INDEMNITY INSURANCE COMPANY (the Company), a corporation organized and existing under the laws of the Commonwealth of Pennsylvania, does hereby constitute and appoint JANINA MONROE, THOMAS G. MCCALL, TIMOTHY J. NOONAN, MICHELLE HAASE, MARTHA BARRERAS AND RACHEL A. MULLEN OF LOCKTON COMPANIES, LLC, its true and lawful Attorney-in-fact with full authority to execute on its behalf bonds, undertakings, recognizances and other contracts of indemnity and writings obligatory in the nature thereof, issued in the course of its business and to bind the Company thereby, in an amount not to exceed \$50,000,000.

This Power of Attorney is granted and is signed and sealed by facsimile under and by the authority of the following Resolution adopted by the Board of Directors of PHILADELPHIA INDEMNITY INSURANCE COMPANY on the 14th of November, 2016.

RESOLVED: That the Board of Directors hereby authorizes the President or any Vice President of the Company: (1) Appoint Attorney(s) in Fact and authorize the Attorney(s) in Fact to execute on behalf of the Company bonds and undertakings, contracts of indemnity and other writings obligatory in the nature thereof and to attach the seal of the Company thereto; and (2) to remove, at any time, any such Attorney-in-Fact and revoke the authority given. And, be it

FURTHER RESOLVED: That the signatures of such officers and the seal of the Company may be affixed to any such Power of Attorney or certificate relating thereto by facsimile, and any such Power of Attorney so executed and certified by facsimile signatures and facsimile seal shall be valid and binding upon the Company in the future with respect to any bond or undertaking to which it is attached.

IN TESTIMONY WHEREOF, PHILADELPHIA INDEMNITY INSURANCE COMPANY HAS CAUSED THIS INSTRUMENT TO BE SIGNED AND ITS CORPORATE SEAL TO BE AFFIXED BY ITS AUTHORIZED OFFICE THIS 5TH DAY OF MARCH, 2021.



(Seal)

John Glomb, President & CEO
Philadelphia Indemnity Insurance Company

On this 5th day of March, 2021 before me came the individual who executed the preceding instrument, to me personally known, and being by me duly sworn said that he is the therein described and authorized officer of the PHILADELPHIA INDEMNITY INSURANCE COMPANY; that the seal affixed to said instrument is the Corporate seal of said Company; that the said Corporate Seal and his signature were duly affixed.

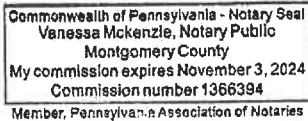

Notary Public:

Vanessa mckenzie

residing at:

Bala Cynwyd, PA

My commission expires:

November 3, 2024

I, Edward Sayago, Corporate Secretary of PHILADELPHIA INDEMNITY INSURANCE COMPANY, do hereby certify that the foregoing resolution of the Board of Directors and the Power of Attorney issued pursuant thereto on the 5th day March, 2021 are true and correct and are still in full force and effect. I do further certify that John Glomb, who executed the Power of Attorney as President, was on the date of execution of the attached Power of Attorney the duly elected President of PHILADELPHIA INDEMNITY INSURANCE COMPANY.

FEB 12 2024

In Testimony Whereof I have subscribed my name and affixed the facsimile seal of each Company this _____ day of _____.



Edward Sayago, Corporate Secretary
PHILADELPHIA INDEMNITY INSURANCE COMPANY

ACKNOWLEDGMENT

A notary public or other officer completing this certificate verifies only the identity of the individual who signed the document to which this certificate is attached, and not the truthfulness, accuracy, or validity of that document.

State of California
County of Riverside)

On 02/13/2024 before me, Edelmira Gonzales / Notary Public
(insert name and title of the officer)

personally appeared Matt Sauls,
who proved to me on the basis of satisfactory evidence to be the person(s) whose name(s) is/are subscribed to the within instrument and acknowledged to me that he/she/they executed the same in his/her/their authorized capacity(ies), and that by his/her/their signature(s) on the instrument the person(s), or the entity upon behalf of which the person(s) acted, executed the instrument.

I certify under PENALTY OF PERJURY under the laws of the State of California that the foregoing paragraph is true and correct.

WITNESS my hand and official seal.

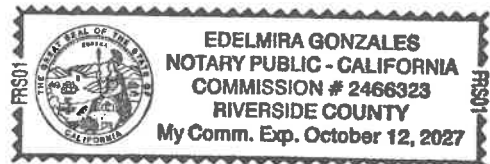

Signature Edelmira Gonzales (Seal)

PAYMENT BOND

WHEREAS, the City Council of the City of Beaumont, State of California, and Tri Pointe Homes IE-SD, Inc. (hereafter designated as "the Principal") have entered into Agreement To Provide Security For Improvements For Tract Map Or Parcel Map Or Plot Plan, Tract 31470-6 (PA 34) dated February 17, 2024, whereby Principal agrees to install and complete certain designated public improvements which is hereby incorporated herein and made a part hereof; and

WHEREAS, under the terms of the said agreement, the Principal is required before entering upon the performance of the work, to file a good and sufficient payment bond with the City of Beaumont to secure the claims to which reference is made in Title 3 (commencing with Section 9000, et seq.) of Part 6 of Division 4 of the Civil Code of the State of California.

NOW, THEREFORE, the Principal and the undersigned as corporate surety, are held firmly bound unto the City of Beaumont and all contractors, subcontractors, laborers, materialmen, and other persons employed in the performance of the said agreement and referred to at Title 3 (commencing with Section 9000, et seq.) of Part 6 of Division 4 of the Civil Code in the sum of *** dollars (\$ ***), for materials furnished or labor thereon of any kind, or for amounts due under the Unemployment Insurance Act with respect to this work or labor, that the Surety will pay the same in an amount not exceeding the amount hereinabove set forth, and also in case suit is brought upon this bond, will pay, in addition to the face amount thereof, costs and reasonable expenses and fees, including reasonable attorney's fees, incurred by the City in successfully enforcing this obligation, to be awarded and fixed by the court, and to be taxed as costs and to be included in the judgment therein rendered.

One Hundred Fifty-Two Thousand One Hundred Forty-Five and no/100 Dollars (\$152,145.00)

It is hereby expressly stipulated and agreed that this bond shall inure to the benefit of any and all persons, companies, and corporations entitled to file claims under Title 3 (commencing with Section 9000, et seq.) of Part 6 of Division 4 of the Civil Code, so as to give a right of action to them or their assigns in any suit brought upon this bond.

Should the condition of this bond be fully performed, then this obligation shall become null and void, otherwise it shall be and remain in full force and effect.

The Surety hereby stipulates and agrees that no change, extension of time, alteration, or addition to the terms of the agreement or the specifications accompanying the same shall in any manner affect its obligations on this bond, and it does hereby waive notice of any such change, extension, alteration, or addition.

[signatures on following page]

IN WITNESS WHEREOF, this instrument has been duly executed by the Principal and Surety above named, on the 12th of February, 2024.



(Seal)

(Seal)

Philadelphia Indemnity Insurance Company

Tri Pointe Homes IE-SD, Inc.

SURETY

PRINCIPAL

By: Michelle Haase

By: Matt Sauls

Name: Michelle Haase

Name: Matt Sauls

Title: Attorney-in-Fact

Title: SVP Business Operations

Address: 800 E. Colorado Blvd., 6th Floor

By: _____

Pasadena, CA 91101

Name: _____

Title: _____

Address: 1250 Corona Pointe Court, Suite 600

Corona, CA 92879

ALL SIGNATURES MUST BE ACKNOWLEDGED BEFORE A NOTARY PUBLIC

ALL- PURPOSE CERTIFICATE OF ACKNOWLEDGMENT

A notary public or other officer completing this certificate verifies only the identity of the individual who signed the document to which this certificate is attached, and not the truthfulness, accuracy, or validity of that document.

State of California }

County of Orange }

On FEB 12 2024 before me, Janina Monroe, Notary Public
(Here insert name and title of the officer)

personally appeared Michelle Haase
 who proved to me on the basis of satisfactory evidence to be the person(s) whose name(s) is/~~are~~ subscribed to the within instrument and acknowledged to me that he/~~she/they~~ executed the same in his/~~her/their~~ authorized capacity(~~ies~~), and that by his/~~her/their~~ signature(~~s~~) on the instrument the person(s), or the entity upon behalf of which the person(s) acted, executed the instrument.

I certify under PENALTY OF PERJURY under the laws of the State of California that the foregoing paragraph is true and correct.

WITNESS my hand and official seal.

Notary Public Signature

(Notary Public Seal)

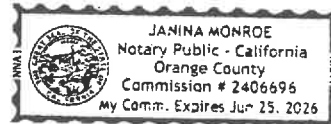

ADDITIONAL OPTIONAL INFORMATION

DESCRIPTION OF THE ATTACHED DOCUMENT

(Title or description of attached document)

(Title or description of attached document continued)

Number of Pages _____ Document Date _____

CAPACITY CLAIMED BY THE SIGNER

Individual (s)

Corporate Officer

_____ (Title)

Partner(s)

Attorney-in-Fact

Trustee(s)

Other _____

INSTRUCTIONS FOR COMPLETING THIS FORM

This form complies with current California statutes regarding notary wording and, if needed, should be completed and attached to the document. Acknowledgments from other states may be completed for documents being sent to that state so long as the wording does not require the California notary to violate California notary law.

- State and County information must be the State and County where the document signer(s) personally appeared before the notary public for acknowledgment.
- Date of notarization must be the date that the signer(s) personally appeared which must also be the same date the acknowledgment is completed.
- The notary public must print his or her name as it appears within his or her commission followed by a comma and then your title (notary public).
- Print the name(s) of document signer(s) who personally appear at the time of notarization.
- Indicate the correct singular or plural forms by crossing off incorrect forms (i.e. he/~~she/they~~, is /~~are~~) or circling the correct forms. Failure to correctly indicate this information may lead to rejection of document recording.
- The notary seal impression must be clear and photographically reproducible. Impression must not cover text or lines. If seal impression smudges, re-seal if a sufficient area permits, otherwise complete a different acknowledgment form.
- Signature of the notary public must match the signature on file with the office of the county clerk.
 - ❖ Additional information is not required but could help to ensure this acknowledgment is not misused or attached to a different document.
 - ❖ Indicate title or type of attached document, number of pages and date.
 - ❖ Indicate the capacity claimed by the signer. If the claimed capacity is a corporate officer, indicate the title (i.e. CEO, CFO, Secretary).
- Securely attach this document to the signed document with a staple.

PHILADELPHIA INDEMNITY INSURANCE COMPANY
One Bala Plaza, Suite 100
Bala Cynwyd, PA 19004-0950

Power of Attorney

KNOW ALL PERSONS BY THESE PRESENTS: That PHILADELPHIA INDEMNITY INSURANCE COMPANY (the Company), a corporation organized and existing under the laws of the Commonwealth of Pennsylvania, does hereby constitute and appoint JANINA MONROE, THOMAS G. MCCALL, TIMOTHY J. NOONAN, MICHELLE HAASE, MARTHA BARRERAS AND RACHEL A. MULLEN OF LOCKTON COMPANIES, LLC, its true and lawful Attorney-in-fact with full authority to execute on its behalf bonds, undertakings, recognizances and other contracts of indemnity and writings obligatory in the nature thereof, issued in the course of its business and to bind the Company thereby, in an amount not to exceed \$50,000,000.

This Power of Attorney is granted and is signed and sealed by facsimile under and by the authority of the following Resolution adopted by the Board of Directors of PHILADELPHIA INDEMNITY INSURANCE COMPANY on the 14th of November, 2016.

RESOLVED: That the Board of Directors hereby authorizes the President or any Vice President of the Company: (1) Appoint Attorney(s) in Fact and authorize the Attorney(s) in Fact to execute on behalf of the Company bonds and undertakings, contracts of indemnity and other writings obligatory in the nature thereof and to attach the seal of the Company thereto; and (2) to remove, at any time, any such Attorney-in-Fact and revoke the authority given. And, be it

FURTHER RESOLVED: That the signatures of such officers and the seal of the Company may be affixed to any such Power of Attorney or certificate relating thereto by facsimile, and any such Power of Attorney so executed and certified by facsimile signatures and facsimile seal shall be valid and binding upon the Company in the future with respect to any bond or undertaking to which it is attached.

IN TESTIMONY WHEREOF, PHILADELPHIA INDEMNITY INSURANCE COMPANY HAS CAUSED THIS INSTRUMENT TO BE SIGNED AND ITS CORPORATE SEAL TO BE AFFIXED BY ITS AUTHORIZED OFFICE THIS 5TH DAY OF MARCH, 2021.



(Seal)

John Glomb, President & CEO
Philadelphia Indemnity Insurance Company

On this 5th day of March, 2021 before me came the individual who executed the preceding instrument, to me personally known, and being by me duly sworn said that he is the therein described and authorized officer of the PHILADELPHIA INDEMNITY INSURANCE COMPANY; that the seal affixed to said instrument is the Corporate seal of said Company; that the said Corporate Seal and his signature were duly affixed.

Notary Public:

Vanessa mckenzie

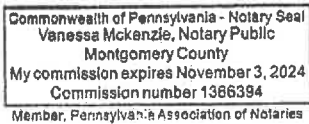

residing at:

Bala Cynwyd, PA

My commission expires:

November 3, 2024

I, Edward Sayago, Corporate Secretary of PHILADELPHIA INDEMNITY INSURANCE COMPANY, do hereby certify that the foregoing resolution of the Board of Directors and the Power of Attorney issued pursuant thereto on the 5th day March, 2021 are true and correct and are still in full force and effect. I do further certify that John Glomb, who executed the Power of Attorney as President, was on the date of execution of the attached Power of Attorney the duly elected President of PHILADELPHIA INDEMNITY INSURANCE COMPANY.

FEB 12 2024

In Testimony Whereof I have subscribed my name and affixed the facsimile seal of each Company this _____ day of _____



Edward Sayago, Corporate Secretary
PHILADELPHIA INDEMNITY INSURANCE COMPANY

ACKNOWLEDGMENT

A notary public or other officer completing this certificate verifies only the identity of the individual who signed the document to which this certificate is attached, and not the truthfulness, accuracy, or validity of that document.

State of California
County of Riverside)

On 02/13/2024 before me, Edelmira Gonzales / Notary Public
(insert name and title of the officer)

personally appeared Matt Sauls,
who proved to me on the basis of satisfactory evidence to be the person(s) whose name(s) is/are subscribed to the within instrument and acknowledged to me that he/she/they executed the same in his/her/their authorized capacity(ies), and that by his/her/their signature(s) on the instrument the person(s), or the entity upon behalf of which the person(s) acted, executed the instrument.

I certify under PENALTY OF PERJURY under the laws of the State of California that the foregoing paragraph is true and correct.

WITNESS my hand and official seal.

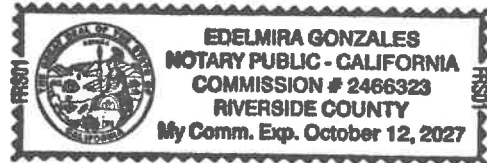

Signature Edelmira Gonzales (Seal)

CITY OF BEAUMONT PUBLIC WORKS DEPARTMENT
CONSTRUCTION COST WORKSHEET

PROJECT NAME: Sundance North - Tract 31470-6
DATE: 19-Nov-20

PP, CUP NO.: _____ BY: Mauricio Iacueli, Michael Baker Intl

IMPROVEMENTS	FAITHFUL PERFORMANCE	100%
	LABOR & MATERIALS SECURITY	100%
<hr/>		
	Construction Costs)	
Street /Drainage	\$ 1,257,674.50	\$152,145.00
Sewer	\$ -	
Total	\$ 1,257,674.50	\$152,145.00
Warranty Retention (22.5%)	\$ 282,976.76	\$34,233.00
<hr/>		
Street /Drainage Plan Check Fees =	\$ 21,872.60	
Sewer Plan Check Fees =	\$ -	
Street Inspection Fees =	\$ 32,808.90	
Sewer Inspection Fees =	\$ -	

DESIGN ENGINEERS CALCULATIONS OF IMPROVEMENT BONDING COSTS

Construction items and their quantities as shown on attached sheets are accurate for the improvements required to construct the above project and the mathematical extensions using City's unit costs are accurate for determining bonding, plan check and inspection costs.

Above amounts do include additional 20% for recordation prior to having signed plans

Above amounts do not include additional 20% for recordation prior to having signed plans

Mauricio M. Iacueli 11/19/20
Engineer's Signature Date

Mauricio M. Iacueli
Name typed or printed



Civil Engineer's Stamp

FORM \$ UNIT COSTS REVISED 09/06

*****PLEASE READ INSTRUCTIONS BELOW*****

- Quantities to be taken from improvement plans, Unit costs to be as provided on "City of Beaumont Improvement Requirement Worksheet".
- Show Bond Amounts to the nearest \$500.
- For construction items not covered by "City of Beaumont Improvement Worksheet", Design Engineer is to provide his opinion of construction cost and use of that cost. If City of Beaumont Unit Costs are determined to be too low in the opinion of the Design Engineer, the higher costs as provided by the Design Engineer should be used.

CITY OF BEAUMONT PUBLIC WORKS DEPARTMENT
IMPROVEMENT REQUIREMENT WORKSHEET

PROJECT: Sundance North - Tract 31470-6

DATE: 11/19/2020

STREET IMPROVEMENTS				
QTY.	UNIT	ITEM	UNIT COST	AMOUNT
		Roadway Excavation		
2,685	C.Y.	1. Projects with a grading plan area x 0.50' (hinge point to hinge point)(x 144,989)	\$ 15.00	\$ 40,275
		2. Projects without a grading plan (road area and side slopes to daylight Cut (C) = Fill (f) =		
	C.Y. (c or f)	(a.) Excavate and Fill	\$ 0.40	\$ -
	C.Y. (f - c)	(b.) Excavate and Export	\$ 1.10	\$ -
		(c.) Import and Fill	\$ 2.80	\$ -
		If balance, provide (a.) only, either cut or fill		
		If export, provide (a.) & (b.), a = fill, b = cut - fill		
		If import, provide (a.) & (c.), a = cut, c= fill - cut		
		(Unit costs for (a.), (b.) & (c.) are 20% of actual costs to assure that work will be corrected to eliminate hazardous conditions.)		
	S.F.	Grinding A.C. in place	\$ 1.00	\$ -
	S.F.	Remove A.C. Pavement	\$ 1.00	\$ -
	L.F.	Remove Curb and Gutter	\$ 6.00	\$ -
	L.F.	Remove A.C. Dike	\$ 3.00	\$ -
	S.F.	Remove Sidewalk	\$ 3.00	\$ -
128	L.F.	Sawcut & Remove Exist. A.C. Pavement	\$ 2.00	\$ 256
	S.F.	Cold Plane A.C. Pavement	\$ 1.00	\$ -
	E.A.	Relocate Mailbox	\$ 250.00	\$ -
	L.F.	Proto II Block Wall	\$ 40.00	\$ -
				\$ -
				\$ -
				\$ -
				\$ -
				\$ -

CITY OF BEAUMONT PUBLIC WORKS DEPARTMENT
IMPROVEMENT REQUIREMENT WORKSHEET

PROJECT: Sundance North - Tract 31470-6

DATE: 11/19/2020

STREET IMPROVEMENTS (Cont'd.)				
QTY.	UNIT	ITEM	UNIT COST	AMOUNT
	L.F.	Remove Chain Link Fence	\$ 2.50	\$ -
	EA.	Remove Barricade	\$ 200.00	\$ -
3,045	TON	Asphalt Concrete - 144 lbs/cu. Ft. (144,989 SF @ 0.29 Ft.)	\$ 90.00	\$ 274,050
2,685	C.Y.	Aggregate Base Class II (144,989 sf @ 0.5 Ft.)	\$ 50.00	\$ 134,250
	TON	Asphalt Emulsion (Fog Seal/Paint Binder) (1 ton = 240 gals) (108, 946 SF) apply at 0.05 + 0.03 = 0.08 gal/SY	\$ 600.00	\$ -
	S.F	AC overlay (min. 0.10') If export, provide (a) & (b), a=fill, b=cut-fill If import, provide (a)&(C), a=cut, c=fill-cut (Unit costs for (a), (b) & (C) are 20% of actual costs to assure that work will be corrected to eliminate hazardous conditions.)	\$ 1.00	\$ -
	L.F.	Curb and Gutter (Wedge Curb)	\$ 8.00	\$ -
8,219	L.F.	Curb and Gutter (Type A-6)	\$ 10.00	\$ 82,190
	L.F.	Curb and Gutter (Type A-8)	\$ 12.00	\$ -
	L.F.	Type "C" Curb	\$ 10.00	\$ -
	L.F.	Type "D" Curb	\$ 15.00	\$ -
	L.F.	A.C. Dike (6") (incl. material & labor)	\$ 8.00	\$ -
	L.F.	A.C. Dike (8") (incl. Material & labor)	\$ 10.00	\$ -
3,088	S.F.	P.C.C. Cross Gutter and Spandrels	\$ 10.00	\$ 30,880
41,964	S.F.	P.C.C. Sidewalk	\$ 6.00	\$ 251,784
	S.F.	P.C.C. Drive Approach	\$ 8.00	\$ -
11	EA.	Handicapped Access Ramp	\$ 1,500.00	\$ 16,500
15,750	S.F.	P.C.C. Drive Approach (individual lot driveway approach per finished grading plan)	\$ 8.00	\$ 126,000
	S.F.	Cold Plane & Overlay Exist. A.C. Paving	\$ 4.00	\$ -
				\$ -
				\$ -
				\$ -

CITY OF BEAUMONT PUBLIC WORKS DEPARTMENT
IMPROVEMENT REQUIREMENT WORKSHEET

PROJECT: Sundance North - Tract 31470-6

DATE: 11/19/2020

STREET IMPROVEMENTS (Cont'd.)				
QTY.	UNIT	ITEM	UNIT COST	AMOUNT
5	EA.	Street Name Sign	\$ 275.00	\$ 1,375
	EA.	Delineators-per Caltrans Std. A73C, Class 1, Type F	\$ 45.00	\$ -
	EA.	Object Markers - Modified Type F Delineators, Riverside County	\$ 60.00	\$ -
	L.F.	Barricades	\$ 28.00	\$ -
	L.F.	Utility Trench, one side (Edison, Telephone, Cable) (Total length of streets)	\$ 10.00	\$ -
	L.F.	Chain Link Fence (6')	\$ 12.00	\$ -
	L.F.	Remove Fence	\$ 4.00	\$ -
	EA.	Relocate Power Pole	\$ 10,000.00	\$ -
	EA.	Street Lights (including conduit)	\$ 5,000.00	\$ -
	EA.	Street Trees (15 gallon)	\$ 150.00	\$ -
	L.S.	Landscape and Irrigation	\$ -	\$ -
	EA.	Concrete Bulkhead	\$ 200.00	\$ -
	C.Y.	Structural Reinforced Concrete	\$ 400.00	\$ -
	EA.	Slope Anchors for Pipes	\$ 300.00	\$ -
	L.F.	Cut Off Wall (Std. 2')	\$ 5.50	\$ -
	EA.	A.C. Overside Drain	\$ 500.00	\$ -
	EA.	Under Sidewalk Drain Std. 309	\$ 2,000.00	\$ -
	EA.	Flat Outlet Drainage Structure Std. 303	\$ 500.00	\$ -
	EA.	Curb Outlet Drainage Structure Std. 308	\$ 500.00	\$ -
	S.F.	Terrace Drains and Down Drains	\$ 6.50	\$ -
	S.F.	Interceptor Drains	\$ 6.50	\$ -
5	EA.	"STOP" Pavement Marking	\$ 200.00	\$ 1,000
80	L.F.	Limit Line	\$ 2.00	\$ 160
5	EA.	R1 "STOP SIGN"	\$ 250.00	\$ 1,250
	EA.	W53 "NOT A THROUGH STREET"	\$ 250.00	\$ -
68	L.F.	Remove Existing Barricade	\$ 20.00	\$ 1,360
				\$ -
				\$ -
				\$ -
				\$ -
				\$ -

CITY OF BEAUMONT PUBLIC WORKS DEPARTMENT
IMPROVEMENT REQUIREMENT WORKSHEET

PROJECT: Sundance North - Tract 31470-6

DATE: 11/19/2020

STREET IMPROVEMENTS (Cont'd.)				
QTY.	UNIT	ITEM	UNIT COST	AMOUNT
	C.Y.	Rip Rap (1/4 Ton) Method B	\$ 40.00	\$ -
	C.Y.	Rip Rap (1/2 Ton) Method B	\$ 45.00	\$ -
	C.Y.	Rip Rap (1 Ton) Method B	\$ 50.00	\$ -
	C.Y.	Rip Rap (2 Ton) Method B	\$ 55.00	\$ -
	C.Y.	Grouted Rip Rap (1/4 Ton) Method B	\$ 60.00	\$ -
	C.Y.	Grouted Rip Rap (1/2 Ton) Method B	\$ 67.00	\$ -
	C.Y.	Grouted Rip Rap (1Ton) Method B	\$ 75.00	\$ -
	C.Y.	Grouted Rip Rap (2 Ton) Method B	\$ 80.00	\$ -
141	L.F.	18" R.C.P.	\$ 60.00	\$ 8,460
-	L.F.	24" R.C.P.	\$ 70.00	\$ -
518	L.F.	30" R.C.P.	\$ 80.00	\$ 41,440
	L.F.	36" R.C.P.	\$ 90.00	\$ -
	L.F.	42" R.C.P.	\$ 100.00	\$ -
	L.F.	48 " RCP	\$ 110.00	\$ -
	L.F.	54" RCP	\$ 135.00	\$ -
	L.F.	60" RCP	\$ 160.00	\$ -
	L.F.	72" RCP	\$ 200.00	\$ -
	EA.	H.D.P.E. Clean Out	\$ 400.00	\$ -
	EA.	Drain Basin	\$ 400.00	\$ -
	EA.	Curb Outlet	\$ 3,000.00	\$ -
	EA.	Fossil Filters	\$ 500.00	\$ -
	EA.	18" C.M.P. Wye	\$ 500.00	\$ -
	EA.	Riprap Headwall	\$ 1,000.00	\$ -
	EA.	Concrete Collar	\$ 250.00	\$ -
	EA.	Outlet Structure	\$ 10,000.00	\$ -
6	EA.	Connector Pipe Screens	\$ 500.00	\$ 3,000
				\$ -
				\$ -

CITY OF BEAUMONT PUBLIC WORKS DEPARTMENT
IMPROVEMENT REQUIREMENT WORKSHEET

PROJECT: Sundance North - Tract 31470-6

DATE: 11/19/2020

STREET IMPROVEMENTS (Cont'd.)				
QTY.	UNIT	ITEM	UNIT COST	AMOUNT
	L.F.	60" C.S.P.	\$ 115.00	\$ -
	EA.	Catch Basin W = 4'	\$ 1,700.00	\$ -
	EA.	Catch Basin W = 7'	\$ 3,000.00	\$ -
1	EA.	Catch Basin W = 10'	\$ 4,000.00	\$ 4,000
1	EA.	Catch Basin W = 14'	\$ 5,500.00	\$ 5,500
4	EA.	Catch Basin W = 21'	\$ 9,000.00	\$ 36,000
	EA.	Type IX Inlet	\$ 2,500.00	\$ -
1	EA.	Type X Inlet	\$ 2,500.00	\$ 2,500
	EA.	Junction Structure No. 1	\$ 3,000.00	\$ -
	EA.	Junction Structure No. 2 & 4	\$ 2,500.00	\$ -
	EA.	Junction Structure No. 6	\$ 3,700.00	\$ -
	EA.	Transition Structure No. 1	\$ 2,000.00	\$ -
1	EA.	Transition Structure No. 3	\$ 2,700.00	\$ 2,700
3	EA.	Manhole No. 1	\$ 2,700.00	\$ 8,100
	EA.	Manhole No. 2	\$ 3,300.00	\$ -
	EA.	Manhole No. 3	\$ 2,700.00	\$ -
2	EA.	Manhole No. 4	\$ 5,000.00	\$ 10,000
	EA.	Adjust Water Valve (if no water plan)	\$ 150.00	\$ -
	EA.	Adjust MH to grade (if no sewer plan)	\$ 400.00	\$ -
	EA.	Headwall	\$ 5,000.00	\$ -
	L.S.	Remove & Dispose of Interferring 30" Storm Drain and 36" Riser	\$ 500.00	\$ -
	EA.	Remove & Dispose of RCB Headwall & Wingwall	\$ 10,000.00	\$ -
2	EA.	Remove Concrete Bulkhead	\$ 200.00	\$ 400
	EA.	Outlet Structure (Line A & B)	\$ 5,000.00	\$ -
	EA.	Remove Existing Headwall	\$ 1,000.00	\$ -
5	EA.	Local Depression per RCTD Std 311 Case B	\$ 1,200.00	\$ 6,000
1	EA.	Local Depression per RCTD Std 311 Case C	\$ 1,500.00	\$ 1,500
1	EA.	36" Square Drain Inlet	\$ 2,700.00	\$ 2,700
				\$ -
				\$ -

CITY OF BEAUMONT PUBLIC WORKS DEPARTMENT
IMPROVEMENT REQUIREMENT WORKSHEET

PROJECT: Sundance North - Tract 31470-6

DATE: 11/19/2020

STREET IMPROVEMENTS (Cont'd.)				
QTY.	UNIT	ITEM	UNIT COST	AMOUNT
	EA.	Water Quality Structure	\$ 2,500.00	\$ -
	LS	Concrete Inlet Apron	\$ 11,000.00	\$ -
	LS	Emergency Spillway	\$ 27,000.00	\$ -
	LS	84" Storm Drain Grate	\$ 8,500.00	\$ -
	SF	3' Wide V-Gutter	\$ 4.00	\$ -
	LS	Signal & Lighting	\$ 100,000.00	\$ -
				\$ -
				\$ -
				\$ -
				\$ -

Subtotal: \$ -

A. Subtotal **\$132,300** \$ 1,093,630

B. Contingency (15%) **\$19,845** \$ 164,044.50

C. **Streets/Drainage Total (A + B)** **\$152,145** \$ 1,257,675

Basic Gov (Sales Force) # _____
File # _____

EXHIBIT "A"

Bond No. CMS0342150
Premium: \$4,716 / Annually

PERFORMANCE BOND

WHEREAS, the City Council of the City of Beaumont, State of California, and _____
Pardee Homes (hereinafter designated as "Principal") have entered into
Agreement To Provide Security For Improvements For Tract Map Or Parcel Map Or Plot Plan,
dated December 2, 2020, whereby Principal agrees to install and complete certain designated
public improvements itemized and described on Tract Map, Parcel Map or Plot Plan No. TR 3147Q-6
which is hereby incorporated herein and made a part hereof; and Sundance - Street Improvements

WHEREAS, Principal is required under the terms of the said agreement to furnish a bond for the
faithful performance of said agreement.

NOW, THEREFORE, we, the Principal and RLI Insurance Company,
as Surety, are held and firmly bound unto the City of Beaumont (hereinafter called "City"), in the penal
sum of One Million Two Hundred Fifty-Seven Thousand* dollars (\$ 1,257,674.50) lawful money of the
United States, for the payment of which sum well and truly to be made, we bind ourselves, our heirs,
successors, executors and administrators, jointly and severally, firmly by these presents.

*Six Hundred Seventy-Four and 50/100

The condition of this obligation is such that if the Principal, his or its heirs, executors,
administrators, successors or assigns, shall in all things stand to and abide by, and well and truly keep and
perform the covenants, conditions and provisions in the said agreement and any alteration thereof made as
therein provided, on his or their part to be kept and performed at the time and in the manner therein
specified, and in all respects according to their true intent and meaning, and shall indemnify and save
harmless the City, its officers, agents and employees as therein stipulated, then this obligation shall
become null and void; otherwise it shall be and remain in full force and effect.

As part of the obligation secured hereby and in addition to the face amount specified therefor,
there shall be included costs and reasonable expenses and fees, including reasonable attorney's fees,
incurred by the City in successfully enforcing such obligation, all to be taxed as costs and included in any
judgment therein rendered.

The Surety hereby stipulates and agrees that no change, extension of time, alteration or addition
to the terms of the agreement or to the work to be performed thereunder or the specifications
accompanying the same shall in any way affect its obligations on this bond, and it does hereby waive
notice of any such change, extension of time, alteration or addition to the terms of the agreement or to the
work or to the specifications.

IN WITNESS WHEREOF, this instrument has been duly executed by the Principal and Surety
above named, on December 2, 2020.

PRINCIPAL:

Pardee Homes

By Michael C. Taylor
Title Division President

SURETY:

RLI Insurance Company

By Michelle Haase
Title Attorney-in-Fact



ALL-PURPOSE CERTIFICATE OF ACKNOWLEDGMENT

A notary public or other officer completing this certificate verifies only the identity of the individual who signed the document to which this certificate is attached, and not the truthfulness, accuracy, or validity of that document.

State of California }

County of Orange }

On DEC 02 2020 before me, Janina Monroe, Notary Public
(Here insert name and title of the officer)

personally appeared Michelle Haase
 who proved to me on the basis of satisfactory evidence to be the person(s) whose name(s) ~~is/are~~ subscribed to the within instrument and acknowledged to me that ~~he/she/they~~ executed the same in ~~his/her/their~~ authorized capacity(ies), and that by ~~his/her/their~~ signature(s) on the instrument the person(s) or the entity upon behalf of which the person(s) acted, executed the instrument.

I certify under PENALTY OF PERJURY under the laws of the State of California that the foregoing paragraph is true and correct.

WITNESS my hand and official seal.

Notary Public Signature _____ (Notary Public Seal)

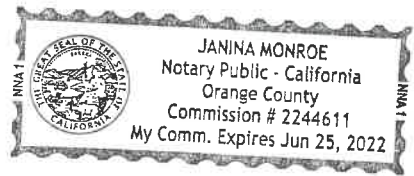

ADDITIONAL OPTIONAL INFORMATION

DESCRIPTION OF THE ATTACHED DOCUMENT

(Title or description of attached document)

(Title or description of attached document continued)

Number of Pages _____ Document Date _____

CAPACITY CLAIMED BY THE SIGNER

Individual (s)
 Corporate Officer

(Title)

Partner(s)
 Attorney-in-Fact
 Trustee(s)
 Other _____

INSTRUCTIONS FOR COMPLETING THIS FORM

This form complies with current California statutes regarding notary wording and, if needed, should be completed and attached to the document. Acknowledgments from other states may be completed for documents being sent to that state so long as the wording does not require the California notary to violate California notary law.

- State and County information must be the State and County where the document signer(s) personally appeared before the notary public for acknowledgment.
- Date of notarization must be the date that the signer(s) personally appeared which must also be the same date the acknowledgment is completed.
- The notary public must print his or her name as it appears within his or her commission followed by a comma and then your title (notary public).
- Print the name(s) of document signer(s) who personally appear at the time of notarization.
- Indicate the correct singular or plural forms by crossing off incorrect forms (i.e. ~~he/she/they~~, is /~~are~~) or circling the correct forms. Failure to correctly indicate this information may lead to rejection of document recording.
- The notary seal impression must be clear and photographically reproducible. Impression must not cover text or lines. If seal impression smudges, re-seal if a sufficient area permits, otherwise complete a different acknowledgment form.
- Signature of the notary public must match the signature on file with the office of the county clerk.
 - ❖ Additional information is not required but could help to ensure this acknowledgment is not misused or attached to a different document.
 - ❖ Indicate title or type of attached document, number of pages and date.
 - ❖ Indicate the capacity claimed by the signer. If the claimed capacity is a corporate officer, indicate the title (i.e. CEO, CFO, Secretary).
- Securely attach this document to the signed document with a staple.

POWER OF ATTORNEY

RLI Insurance Company Contractors Bonding and Insurance Company

9025 N. Lindbergh Dr. Peoria, IL 61615
Phone: 800-645-2402

Know All Men by These Presents:

That this Power of Attorney is not valid or in effect unless attached to the bond which it authorizes executed, but may be detached by the approving officer if desired.

That **RLI Insurance Company** and/or **Contractors Bonding and Insurance Company**, each an Illinois corporation, (separately and together, the "Company") do hereby make, constitute and appoint:

Paul Boucher, Janina Monroe, Dennis Langer, Michelle Haase, Timothy Noonan, Adriana Valenzuela, Jennifer Ochs, jointly or severally

in the City of Los Angeles, State of California its true and lawful Agent(s) and Attorney(s) in Fact, with full power and authority hereby conferred, to sign, execute, acknowledge and deliver for and on its behalf as Surety, in general, any and all bonds and undertakings in an amount not to exceed Twenty Five Million Dollars (\$25,000,000.00) for any single obligation.

The acknowledgment and execution of such bond by the said Attorney in Fact shall be as binding upon the Company as if such bond had been executed and acknowledged by the regularly elected officers of the Company.

RLI Insurance Company and/or **Contractors Bonding and Insurance Company**, as applicable, have each further certified that the following is a true and exact copy of a Resolution adopted by the Board of Directors of each such corporation, and is now in force, to-wit:

"All bonds, policies, undertakings, Powers of Attorney or other obligations of the corporation shall be executed in the corporate name of the Company by the President, Secretary, any Assistant Secretary, Treasurer, or any Vice President, or by such other officers as the Board of Directors may authorize. The President, any Vice President, Secretary, any Assistant Secretary, or the Treasurer may appoint Attorneys in Fact or Agents who shall have authority to issue bonds, policies or undertakings in the name of the Company. The corporate seal is not necessary for the validity of any bonds, policies, undertakings, Powers of Attorney or other obligations of the corporation. The signature of any such officer and the corporate seal may be printed by facsimile."

IN WITNESS WHEREOF, the **RLI Insurance Company** and/or **Contractors Bonding and Insurance Company**, as applicable, have caused these presents to be executed by its respective Vice President with its corporate seal affixed this 24th day of March, 2020.



**RLI Insurance Company
Contractors Bonding and Insurance Company**
By: Barton W. Davis Vice President

State of Illinois }
County of Peoria } SS

CERTIFICATE

On this 24th day of March, 2020, before me, a Notary Public, personally appeared Barton W. Davis, who being by me duly sworn, acknowledged that he signed the above Power of Attorney as the aforesaid officer of the **RLI Insurance Company** and/or **Contractors Bonding and Insurance Company** and acknowledged said instrument to be the voluntary act and deed of said corporation.

I, the undersigned officer of **RLI Insurance Company** and/or **Contractors Bonding and Insurance Company**, do hereby certify that the attached Power of Attorney is in full force and effect and is irrevocable; and furthermore, that the Resolution of the Company as set forth in the Power of Attorney, is now in force. In testimony whereof, I have hereunto set my hand and the seal of the **RLI Insurance Company** and/or **Contractors Bonding and Insurance Company** this 2nd day of December, 2020.

By: Jacqueline M. Bockler Notary Public

**RLI Insurance Company
Contractors Bonding and Insurance Company**
By: Jeffrey D. Jick Corporate Secretary



California All-Purpose Certificate of Acknowledgment

A notary public or other officer completing this certificate verifies only the identity of the individual who signed the document to which this certificate is attached, and not the truthfulness, accuracy, or validity of that document.

State of California

County of Riverside

} s.s.

On December 7, 2020 before me, Ana E. Chavez Perez, Notary Public

Name of Notary Public, Title

personally appeared Michael C. Taylor

Name of Signer (1)

Name of Signer (2)

who proved to me on the basis of satisfactory evidence to be the person(s) whose name(s) is/are subscribed to the within instrument and acknowledged to me that he/she/they executed the same in his/her/their authorized capacity(ies), and that by his/her/their signature(s) on the instrument the person(s), or the entity upon behalf of which the person(s) acted, executed the instrument.

I certify under PENALTY OF PERJURY under the laws of the State of California that the foregoing paragraph is true and correct.

WITNESS my hand and official seal.

Signature of Notary Public



OPTIONAL INFORMATION

Although the information in this section is not required by law, it could prevent fraudulent removal and reattachment of this acknowledgment to an unauthorized document and may prove useful to persons relying on the attached document.

Description of Attached Document

The preceding Certificate of Acknowledgment is attached to a document titled/for the purpose of _____

containing _____ pages, and dated _____.

The signer(s) capacity or authority is/are as:

- Individual(s)
 Attorney-in-fact
 Corporate Officer(s) _____
Title(s) _____

- Guardian/Conservator
 Partner - Limited/General
 Trustee(s)
 Other: _____

representing: _____
Name(s) of Person(s) Entity(ies) Signer is Representing

Additional Information

Method of Signer Identification

Proved to me on the basis of satisfactory evidence:

- form(s) of identification credible witness(es)

Notarial event is detailed in notary journal on:

Page # _____ Entry # _____

Notary contact: _____

Other

- Additional Signer Signer(s) Thumbprints(s)

EXHIBIT "B"

PAYMENT BOND

WHEREAS, the City Council of the City of Beaumont, State of California, and Pardee Homes (hereafter designated as "the Principal") have entered into Agreement To Provide Security For Improvements For Tract Map Or Parcel Map Or Plot Plan, dated December 2, 2020, whereby Principal agrees to install and complete certain designated public improvements itemized and described on Tract Map, Parcel Map or Plot Plan No. TR 31470-6 which is hereby incorporated herein and made a part hereof; and Sundance - Street Improvements

WHEREAS, under the terms of the said agreement, the Principal is required before entering upon the performance of the work, to file a good and sufficient payment bond with the City of Beaumont to secure the claims to which reference is made in Section 8000, et seq., of the Civil Code of the State of California.

NOW, THEREFORE, the Principal and the undersigned as corporate surety, are held firmly bound unto the City of Beaumont and all contractors, subcontractors, laborers, materialmen, and other persons employed in the performance of the said agreement and referred to at Section 8000, et seq., of the Civil Code in the sum of One Million Two Hundred Fifty-Seven Thousand dollars (\$ 1,257,674.50), for materials furnished or labor thereon of any kind, or for amounts due under the Unemployment Insurance Act with respect to this work or labor, that the Surety will pay the same in an amount not exceeding the amount hereinabove set forth, and also in case suit is brought upon this bond, will pay, in addition to the face amount thereof, costs and reasonable expenses and fees, including reasonable attorney's fees, incurred by the City in successfully enforcing this obligation, to be awarded and fixed by the court, and to be taxed as costs and to be included in the judgment therein rendered. *Six Hundred Seventy-Four and 50/100

It is hereby expressly stipulated and agreed that this bond shall inure to the benefit of any and all persons, companies, and corporations entitled to file claims under Section 8000, et seq., of the Civil Code, so as to give a right of action to them or their assigns in any suit brought upon this bond.

Should the condition of this bond be fully performed, then this obligation shall become null and void, otherwise it shall be and remain in full force and effect.

The Surety hereby stipulates and agrees that no change, extension of time, alteration, or addition to the terms of the agreement or the specifications accompanying the same shall in any manner affect its obligations on this bond, and it does hereby waive notice of any such change, extension, alteration, or addition.

IN WITNESS WHEREOF, this instrument has been duly executed by the Principal and Surety above named, on December 2, 2020.

PRINCIPAL:

Pardee Homes

By Michael C. Taylor
Title Division President

SURETY:

RLI Insurance Company

By Michelle Haase
Title Attorney-in-Fact



ALL- PURPOSE CERTIFICATE OF ACKNOWLEDGMENT

A notary public or other officer completing this certificate verifies only the identity of the individual who signed the document to which this certificate is attached, and not the truthfulness, accuracy, or validity of that document.

State of California }

County of Orange }

On DEC 02 2020 before me, Janina Monroe, Notary Public
(Here insert name and title of the officer)

personally appeared Michelle Haase,

who proved to me on the basis of satisfactory evidence to be the person(s) whose name(s) is/are subscribed to the within instrument and acknowledged to me that he/she/they executed the same in his/her/their authorized capacity(ies), and that by his/her/their signature(s) on the instrument the person(s) or the entity upon behalf of which the person(s) acted, executed the instrument.

I certify under PENALTY OF PERJURY under the laws of the State of California that the foregoing paragraph is true and correct.

WITNESS my hand and official seal.

Notary Public Signature

(Notary Public Seal)



ADDITIONAL OPTIONAL INFORMATION

DESCRIPTION OF THE ATTACHED DOCUMENT

(Title or description of attached document)

(Title or description of attached document continued)

Number of Pages _____ Document Date _____

CAPACITY CLAIMED BY THE SIGNER

- Individual (s)
 Corporate Officer

(Title)

- Partner(s)
 Attorney-in-Fact
 Trustee(s)
 Other _____

INSTRUCTIONS FOR COMPLETING THIS FORM

This form complies with current California statutes regarding notary wording and, if needed, should be completed and attached to the document. Acknowledgments from other states may be completed for documents being sent to that state so long as the wording does not require the California notary to violate California notary law.

- State and County information must be the State and County where the document signer(s) personally appeared before the notary public for acknowledgment.
- Date of notarization must be the date that the signer(s) personally appeared which must also be the same date the acknowledgment is completed.
- The notary public must print his or her name as it appears within his or her commission followed by a comma and then your title (notary public).
- Print the name(s) of document signer(s) who personally appear at the time of notarization.
- Indicate the correct singular or plural forms by crossing off incorrect forms (i.e. ~~he/she/they~~, is /are) or circling the correct forms. Failure to correctly indicate this information may lead to rejection of document recording.
- The notary seal impression must be clear and photographically reproducible. Impression must not cover text or lines. If seal impression smudges, re-seal if a sufficient area permits, otherwise complete a different acknowledgment form.
- Signature of the notary public must match the signature on file with the office of the county clerk.
 - ❖ Additional information is not required but could help to ensure this acknowledgment is not misused or attached to a different document.
 - ❖ Indicate title or type of attached document, number of pages and date.
 - ❖ Indicate the capacity claimed by the signer. If the claimed capacity is a corporate officer, indicate the title (i.e. CEO, CFO, Secretary).
- Securely attach this document to the signed document with a staple.

POWER OF ATTORNEY

RLI Insurance Company Contractors Bonding and Insurance Company

9025 N. Lindbergh Dr. Peoria, IL 61615
Phone: 800-645-2402

Know All Men by These Presents:

That this Power of Attorney is not valid or in effect unless attached to the bond which it authorizes executed, but may be detached by the approving officer if desired.

That **RLI Insurance Company** and/or **Contractors Bonding and Insurance Company**, each an Illinois corporation, (separately and together, the "Company") do hereby make, constitute and appoint:

Paul Boucher, Janina Monroe, Dennis Langer, Michelle Haase, Timothy Noonan, Adriana Valenzuela, Jennifer Ochs, jointly or severally

in the City of Los Angeles, State of California its true and lawful Agent(s) and Attorney(s) in Fact, with full power and authority hereby conferred, to sign, execute, acknowledge and deliver for and on its behalf as Surety, in general, any and all bonds and undertakings in an amount not to exceed Twenty Five Million Dollars (\$25,000,000.00) for any single obligation.

The acknowledgment and execution of such bond by the said Attorney in Fact shall be as binding upon the Company as if such bond had been executed and acknowledged by the regularly elected officers of the Company.

RLI Insurance Company and/or **Contractors Bonding and Insurance Company**, as applicable, have each further certified that the following is a true and exact copy of a Resolution adopted by the Board of Directors of each such corporation, and is now in force, to-wit:

"All bonds, policies, undertakings, Powers of Attorney or other obligations of the corporation shall be executed in the corporate name of the Company by the President, Secretary, any Assistant Secretary, Treasurer, or any Vice President, or by such other officers as the Board of Directors may authorize. The President, any Vice President, Secretary, any Assistant Secretary, or the Treasurer may appoint Attorneys in Fact or Agents who shall have authority to issue bonds, policies or undertakings in the name of the Company. The corporate seal is not necessary for the validity of any bonds, policies, undertakings, Powers of Attorney or other obligations of the corporation. The signature of any such officer and the corporate seal may be printed by facsimile."

IN WITNESS WHEREOF, the **RLI Insurance Company** and/or **Contractors Bonding and Insurance Company**, as applicable, have caused these presents to be executed by its respective Vice President with its corporate seal affixed this 24th day of March, 2020.



RLI Insurance Company
Contractors Bonding and Insurance Company
By: B. W. Davis
Barton W. Davis Vice President

State of Illinois }
County of Peoria } SS

CERTIFICATE

On this 24th day of March, 2020, before me, a Notary Public, personally appeared Barton W. Davis, who being by me duly sworn, acknowledged that he signed the above Power of Attorney as the aforesaid officer of the **RLI Insurance Company** and/or **Contractors Bonding and Insurance Company** and acknowledged said instrument to be the voluntary act and deed of said corporation.

I, the undersigned officer of **RLI Insurance Company** and/or **Contractors Bonding and Insurance Company**, do hereby certify that the attached Power of Attorney is in full force and effect and is irrevocable; and furthermore, that the Resolution of the Company as set forth in the Power of Attorney, is now in force. In testimony whereof, I have hereunto set my hand and the seal of the **RLI Insurance Company** and/or **Contractors Bonding and Insurance Company** this 2nd day of December, 2020.

By: Jacqueline M. Bockler
Jacqueline M. Bockler Notary Public

RLI Insurance Company
Contractors Bonding and Insurance Company
By: Jeffrey D. Fick
Jeffrey D. Fick Corporate Secretary



California All-Purpose Certificate of Acknowledgment

A notary public or other officer completing this certificate verifies only the identity of the individual who signed the document to which this certificate is attached, and not the truthfulness, accuracy, or validity of that document.

State of California

County of Riverside

} s.s.

On December 7, 2020 before me, Ana E. Chavez Perez, Notary Public,
Name of Notary Public, Title

personally appeared Michael C. Taylor
Name of Signer (1)

Name of Signer (2)

who proved to me on the basis of satisfactory evidence to be the person(s) whose name(s) is/are subscribed to the within instrument and acknowledged to me that he/she/they executed the same in his/her/their authorized capacity(ies), and that by his/her/their signature(s) on the instrument the person(s), or the entity upon behalf of which the person(s) acted, executed the instrument.

I certify under PENALTY OF PERJURY under the laws of the State of California that the foregoing paragraph is true and correct.

WITNESS my hand and official seal.

Signature of Notary Public

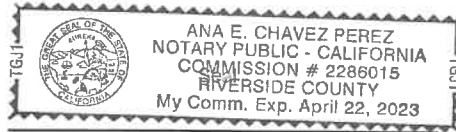

OPTIONAL INFORMATION

Although the information in this section is not required by law, it could prevent fraudulent removal and reattachment of this acknowledgment to an unauthorized document and may prove useful to persons relying on the attached document.

Description of Attached Document

The preceding Certificate of Acknowledgment is attached to a document titled/for the purpose of _____

containing _____ pages, and dated _____

The signer(s) capacity or authority is/are as:

- Individual(s)
- Attorney-in-fact
- Corporate Officer(s) _____
Title(s)

- Guardian/Conservator
- Partner - Limited/General
- Trustee(s)
- Other: _____

representing: _____
Name(s) of Person(s) Entity(ies) Signer is Representing

Additional Information

Method of Signer Identification _____

Proved to me on the basis of satisfactory evidence:
 form(s) of identification credible witness(es)

Notarial event is detailed in notary journal on:

Page # _____ Entry # _____

Notary contact: _____

Other

Additional Signer Signer(s) Thumbprints(s)

PROFILE SCALE:
HORIZ: 1" = 40'
VERT: 1" = 4'

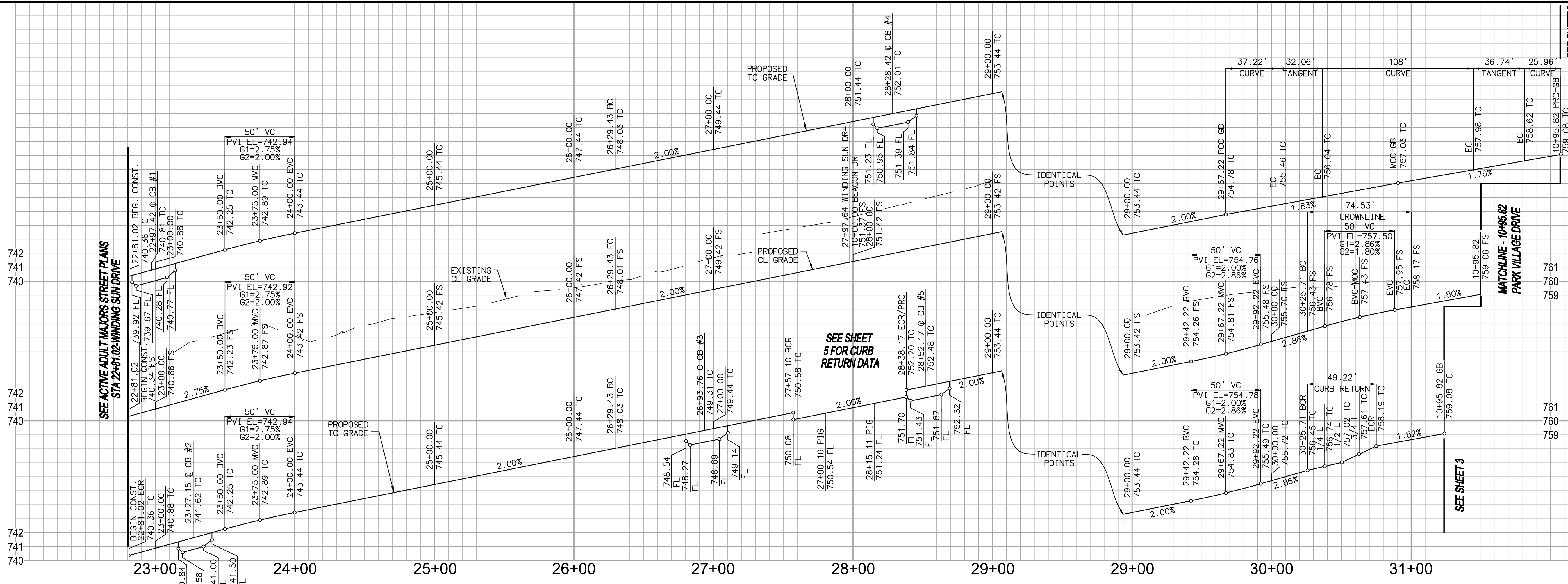

- ### CBC STATEMENTS
1. THE RUNNING SLOPE OF WALKING SURFACES SHALL NOT BE STEEPER THAN 1:20. THE CROSS SLOPE OF WALKING SURFACES SHALL NOT BE STEEPER THAN 1:48 [CBC 11B-403.3].
 2. EXCEPT AS PROVIDED IN SECTIONS 11B-403.5.2 AND 11B-403.5.3, THE CLEAR WIDTH OF WALKING SURFACES SHALL BE 36 INCHES (914 MM) MINIMUM [CBC 11B-403.5.1].
 3. THE CROSS SLOPE OF CURB RAMPS AND BLENDED TRANSITIONS SHALL BE 1:48 MAXIMUM [CBC 11B-406.5.7].
 4. COUNTER SLOPES OF ADJOINING GUTTERS AND ROAD SURFACES IMMEDIATELY ADJACENT TO AND WITHIN 24 INCHES (610 MM) OF THE CURB RAMP SHALL NOT BE STEEPER THAN 1:20. THE ADJACENT SURFACES AT TRANSITIONS AT CURB RAMPS TO WALKS, GUTTERS, AND STREETS SHALL BE AT THE SAME LEVEL [CBC 11B-406.5.8].
 5. THE BOTTOM OF DIAGONAL CURB RAMPS SHALL HAVE A CLEAR SPACE 48 INCHES (1219 MM) MINIMUM OUTSIDE ACTIVE TRAFFIC LANES OF THE ROADWAY. DIAGONAL CURB RAMPS PROVIDED AT MARKED CROSSINGS SHALL PROVIDE THE 48 INCHES (1219 MM) MINIMUM CLEAR SPACE WITHIN THE MARKINGS [CBC 11B-406.5.9].

WINDING SUN DRIVE (PRIVATE)

NO	BEARING/DELTA	RADIUS	LENGTH	TANGENT
1	N 14°37'03" E	—	348.41'	—
2	13°46'04"	700.00'	168.21'	84.51'
3	18°40'04"	700.00'	228.07'	115.05'
4	80°34'16"	53.00'	74.53'	44.92'
5	01°49'09"	1555.00'	49.37'	24.69'
6	03°36'11"	700.00'	44.02'	22.02'
7	01°42'42"	1555.00'	46.45'	23.25'
8	N 14°37'03" E	—	348.41'	—
9	27°38'55"	682.00'	329.11'	167.82'
10	19°23'16"	110.00'	37.22'	18.79'
11	N 32°25'08" W	—	32.06'	—
12	110°30'31"	56.00'	108'	80.74'
13	N 78°05'23" E	—	36.74'	—
14	13°31'03"	110.00'	25.96'	13.04'
15	N 14°37'03" E	—	348.41'	—
16	10°27'00"	718.00'	130.96'	65.66'
17	15°21'00"	718.00'	192.36'	96.76'
18	80°34'16"	35.00'	49.22'	29.67'
19	01°49'09"	1537.00'	48.80'	24.40'

THIS SHEET SUPERSEDES THE PREVIOUSLY APPROVED SHEET 2, APPROVED ON 4/9/2019 INCLUDING THOSE REVISIONS "CLOUDED" AND LABELED WITH △ REVISION TRIANGLES.

6/24/2021
 JOHN D. TANNER III, P.E. DATE
 R.C.E. 60132 EXP. 06-30-2022



- ### CONSTRUCTION NOTES
1. CONSTRUCT 4" AC PAVING OVER 6" CLASS II AGGREGATE BASE
 2. CONSTRUCT TYPE A-6 CURB AND GUTTER PER RCTD STD. NO. 200
 3. CONSTRUCT 10' CROSS GUTTER AND SPANDEL PER RCTD STD. NO. 209
 4. CONSTRUCT SIDEWALK PER RCTD STD. NO. 401 (MODIFIED, WIDTH=5')
 5. CONSTRUCT CURB RAMP, CASE B (WITH TRUNCATED DOMES) PER RCTD STD. NO. 403
 6. CONSTRUCT 18" WIDE DRIVEWAY APPROACH PER DETAIL ON SHEET NO. 1
 7. INSTALL STREET LIGHT PER SEPARATE STREET LIGHT PLAN
 8. REMOVE AND DISPOSE OF EXISTING BARRICADE
 9. CONSTRUCT CATCH BASIN PER RCTD & WCD STD. NO. CB100 (W & V PER PLAN)
 10. CONSTRUCT GUTTER DEPRESSION FOR CURB OPENING CATCH BASIN PER COUNTY OF RIVERSIDE STD. NO. 311, CASE B
 11. INSTALL 36" SQUARE DRAIN INLET PER JENSEN PRECAST D13636 OR APPROVED EQUAL

NOTE:
ALL ELEVATIONS ARE ABBREVIATED AND DO NOT REPRESENT ACTUAL ELEVATIONS. ADD 2000 FEET TO OBTAIN ACTUAL ELEVATION.

NOTE:
WORK CONTAINED WITHIN THESE PLANS SHALL NOT COMMENCE UNTIL AN ENCROACHMENT PERMIT AND/OR A GRADING PERMIT HAS BEEN ISSUED.

THE PRIVATE ENGINEER SIGNING THESE PLANS IS RESPONSIBLE FOR ASSURING THE ACCURACY AND ACCEPTABILITY OF THE DESIGN HEREON, IN THE EVENT OF DISCREPANCIES ARISING AFTER CITY APPROVAL OR DURING CONSTRUCTION, THE PRIVATE ENGINEER SHALL BE RESPONSIBLE FOR DETERMINING AN ACCEPTABLE SOLUTION AND REVISING THE PLANS FOR APPROVED BY THE CITY.

BASIS OF BEARINGS:
 DESCRIPTION:
 BASED ON THE LINE BETWEEN STATIONS "TRAK" AND "MATH" (POSITIONS PER NATIONAL GEODETIC SURVEY, NAD83, EPOCH 1995.5) AS SHOWN ON M.B. 102, PAGES 50 THROUGH 65 OF RECORDS IN COUNTY RECORDER'S OFFICE OF RIVERSIDE COUNTY, CALIFORNIA
 BEARING: N 52°49'02.84" E

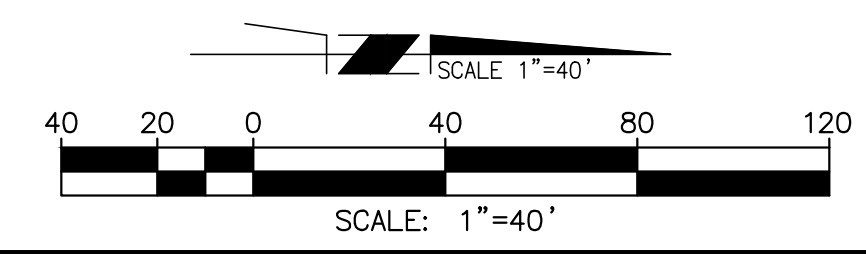

BENCHMARK: CITY OF BEAUMONT NO. 07.A.82
 DESCRIPTION:
 1-3/8" BRASS CAP MONUMENT MARKED "CITY B.M. 7". LOCATED AT THE S.E. CORNER 14TH AND PENNSYLVANIA AVE., 59 FT. S'LY AND 22 FT. E'LY OF CENTERLINE INTERSECTION, 2 FT. S'LY OF B.C.R.

ELEV. = 2678.277 (1982), NGVD 29

BY	MARK	DESCRIPTION	APPR.	DATE
JZ	△	REVISED CONST. NOTE 1 & ADDED CBC NOTES.	JZ	6/24/21
BY	MARK	DESCRIPTION	APPR. <td>DATE</td>	DATE
ENGINEER		REVISIONS	CITY	

Michael Baker INTERNATIONAL
 75410 Gerald Ford Dr. Ste.100
 Palm Desert, CA 92211
 Phone: (760) 346-7481
 MBAKERINTL.COM

JOHN D. TANNER III
 R.C.E. 60132 * EXP. 06/30/22



DESIGN BY: LS
 DRAWN BY: LS
 CHECKED BY: SM
 SCALE: AS NOTED
 DATE: MAY 2021
 JOB NUMBER: 149255



Reviewed By: _____ Date: _____
 Recommended for Approval By: _____ Date: 07/14/2021
 Approved By: _____ Date: 07/20/2021

CITY OF BEAUMONT, PUBLIC WORKS DEPARTMENT
 ENGINEERING DIVISION

NPDES PERMIT#: W01D 833C365311

CITY OF BEAUMONT, CALIFORNIA
 STREET IMPROVEMENT PLANS
 TRACT 31470-6
 WINDING SUN DRIVE
 STA. 22+81.02 TO STA. 30+69.73
 PARK VILLAGE DRIVE
 STA. 10+00.00 TO STA. 10+95.82
 A PORTION OF SEC. 35, T 2 S, R 1 W, SEM

FOR:
 TRI POINTE HOMES

SHEET
2
 OF 8 SHEETS
 FILE NO.: 3247A

PROFILE SCALE:
 HORIZ: 1" = 40'
 VERT: 1" = 4'

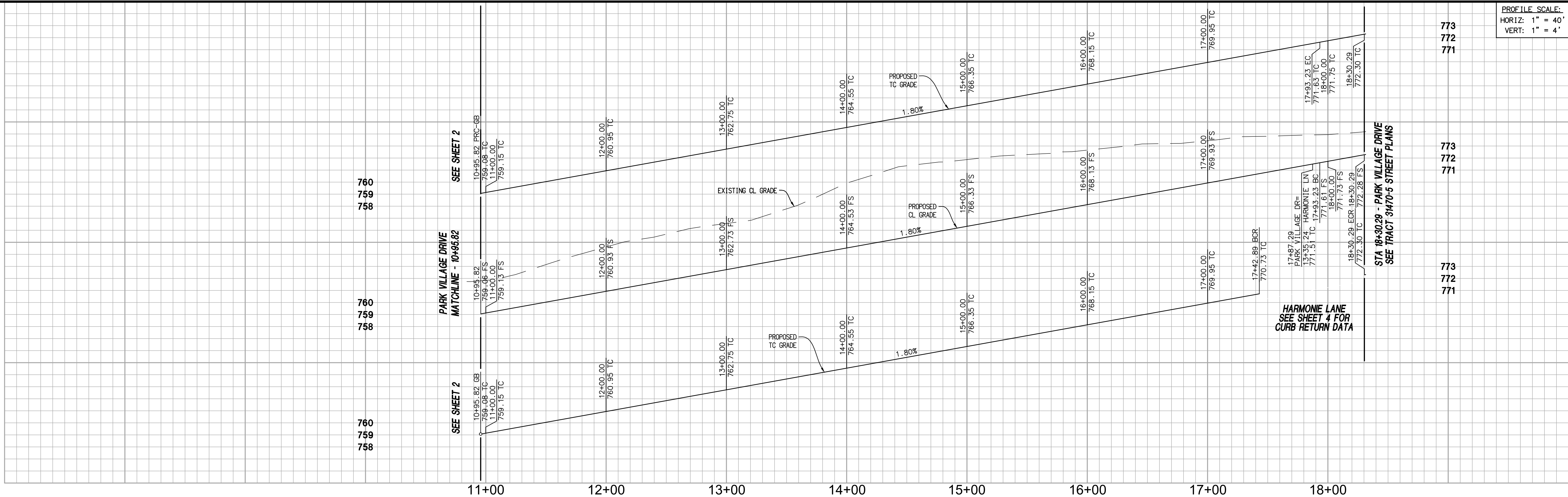

LINE/CURVE DATA TABLE				
NO	BEARING/DELTA	RADIUS	LENGTH	TANGENT
1	25°41'48"	1573.00'	705.48'	358.77'
2	N89°43'52"W	---	37.06'	---
3	23°50'30"	1537.00'	639.58'	324.48'
4	25°41'48"	1555.00'	697.41'	354.67'
5	N89°43'52"W	---	37.06'	---



THIS SHEET SUPERSEDES THE PREVIOUSLY APPROVED SHEET 3 APPROVED ON 4/9/2019 INCLUDING THOSE REVISIONS "CLOUDED" AND LABELED WITH REVISION TRIANGLES.

JOHN D. TANNER III, P.E. DATE 6/24/2021
 R.C.E. 60132 EXP. 06-30-2022

- CONSTRUCTION NOTES**
- CONSTRUCT 4" AC PAVING OVER 6" CLASS II AGGREGATE BASE
 - CONSTRUCT TYPE A-6 CURB AND BUTTER PER RCTD STD. NO. 200
 - CONSTRUCT SIDEWALK PER RCTD STD. NO. 401 (MODIFIED, WIDTH=5')
 - CONSTRUCT CURB RAMP, CASE B (WITH TRUNCATED DOMES) PER RCTD STD. NO. 403
 - CONSTRUCT 18" WIDE DRIVEWAY APPROACH PER DETAIL ON SHEET NO. 1
 - INSTALL STREET LIGHT PER SEPARATE STREET LIGHT PLAN
 - REMOVE AND DISPOSE OF EXISTING BARRICADE
 - SAW CUT AND SMOOTH JOIN EXISTING AC PAVEMENT

NOTE:
 ALL ELEVATIONS ARE ABBREVIATED AND DO NOT REPRESENT ACTUAL ELEVATIONS. ADD 2000 FEET TO OBTAIN ACTUAL ELEVATION.

NOTE:
 WORK CONTAINED WITHIN THESE PLANS SHALL NOT COMMENCE UNTIL AN ENCROACHMENT PERMIT AND/OR A GRADING PERMIT HAS BEEN ISSUED.

THE PRIVATE ENGINEER SIGNING THESE PLANS IS RESPONSIBLE FOR ASSURING THE ACCURACY AND ACCEPTABILITY OF THE DESIGN HEREON. IN THE EVENT OF DISCREPANCIES ARISING AFTER CITY APPROVAL OR DURING CONSTRUCTION, THE PRIVATE ENGINEER SHALL BE RESPONSIBLE FOR DETERMINING AN ACCEPTABLE SOLUTION AND REVISING THE PLANS FOR APPROVED BY THE CITY.

BASIS OF BEARINGS:
 DESCRIPTION:
 BASED ON THE LINE BETWEEN STATIONS "TRAK" AND "MATH" (POSITIONS PER NATIONAL GEODETIC SURVEY, NAD83, EPOCH 1995.5) AS SHOWN ON M.B. 102, PAGES 50 THROUGH 65 OF RECORDS IN COUNTY RECORDER'S OFFICE OF RIVERSIDE COUNTY, CALIFORNIA
 BEARING: N 52°49'02.84" E

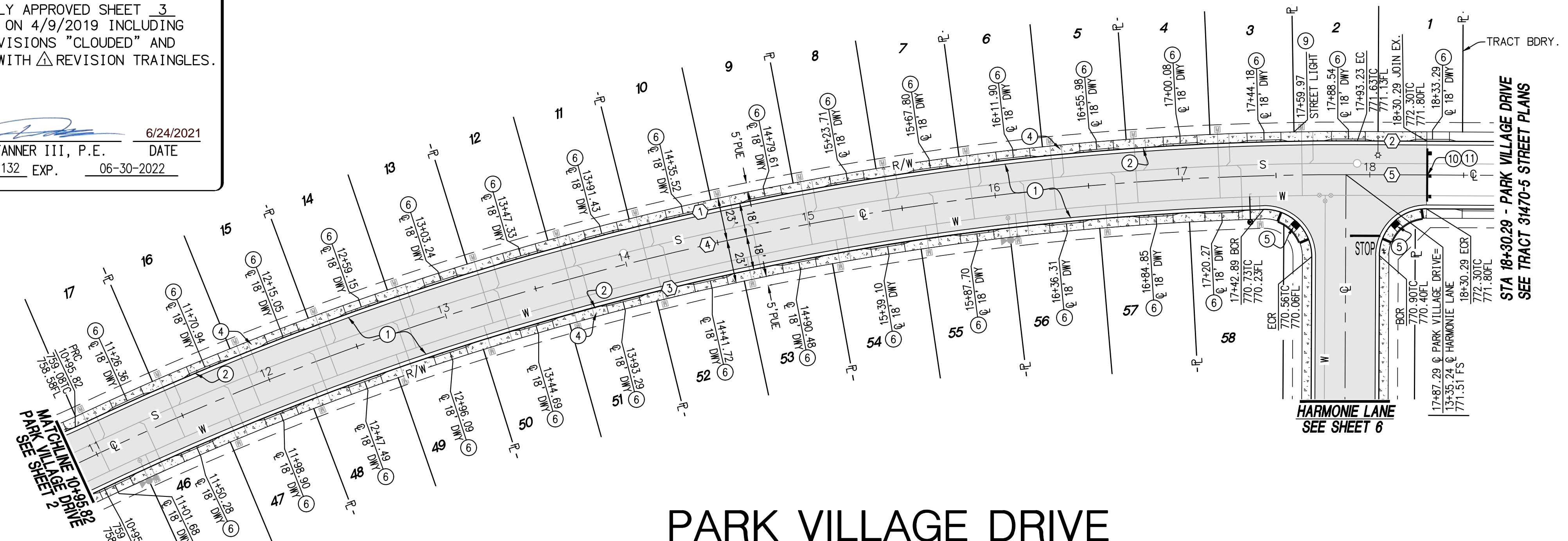
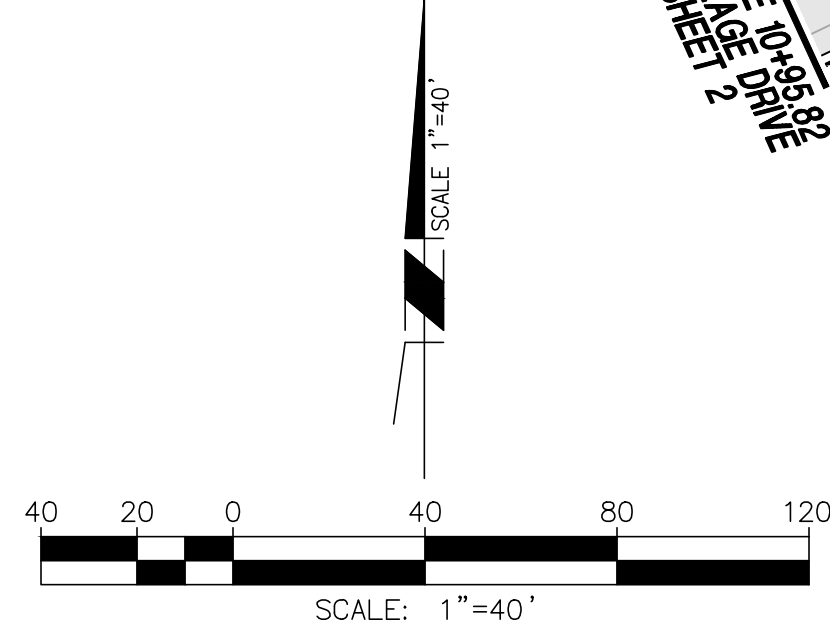

PARK VILLAGE DRIVE (PRIVATE)



BENCHMARK: CITY OF BEAUMONT NO. 07.A.82
 DESCRIPTION:
 1-3/8" BRASS CAP MONUMENT MARKED "CITY B.M. 7". LOCATED AT THE S.E. CORNER 14TH AND PENNSYLVANIA AVE., 59 FT. S'LY AND 22 FT. E'LY OF CENTERLINE INTERSECTION, 2 FT. S'LY OF B.C.R.

ELEV. = 2678.277 (1982), NGVD 29

BY	MARK	DESCRIPTION	APPR.	DATE
JZ	△	REVISED CONST. NOTE 1.		6/24/21
BY	MARK	DESCRIPTION	APPR.	DATE
ENGINEER		REVISIONS		CITY

Michael Baker INTERNATIONAL
 75410 Gerald Ford Dr. Ste.100
 Palm Desert, CA 92211
 Phone: (760) 346-7481
 MBAKERINTL.COM

JOHN D. TANNER III
 R.C.E. 60132 * EXP. 06/30/22



DESIGN BY: LS
 DRAWN BY: LS
 CHECKED BY: SM
 SCALE: AS NOTED
 DATE: MAY 2021
 JOB NUMBER: 149255

Reviewed By: _____ Date: _____
 Recommended for Approval By: *[Signature]* Date: 07/14/2021
 Approved By: *[Signature]* Date: 07/20/2021

CITY OF BEAUMONT, PUBLIC WORKS DEPARTMENT
 ENGINEERING DIVISION

NPDES PERMIT#: WDD1 833C365311

CITY OF BEAUMONT, CALIFORNIA
 STREET IMPROVEMENT PLANS
 TRACT 31470-6

PARK VILLAGE DRIVE
 STA. 10+95.82 TO STA. 18+30.29

A PORTION OF SEC. 35, T 2 S, R 1 W, SBM

TRI POINTE HOMES

SHEET 3 OF 8 SHEETS
 FILE NO: 32477A

REVISED: 06/24/2021
 F:\PDA\TA\146481\CADD\LAND\ULV\IMPROVE\STREET\31470-6\149255-ST-003.DWG - JACOB.ZEPEDA 3/30/21 1:25 pm

REVISED: 06/24/2021

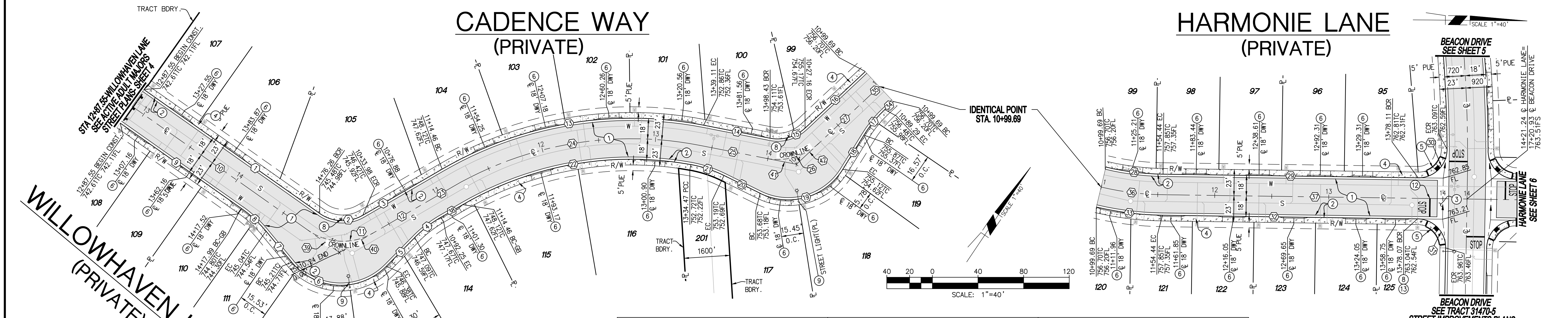
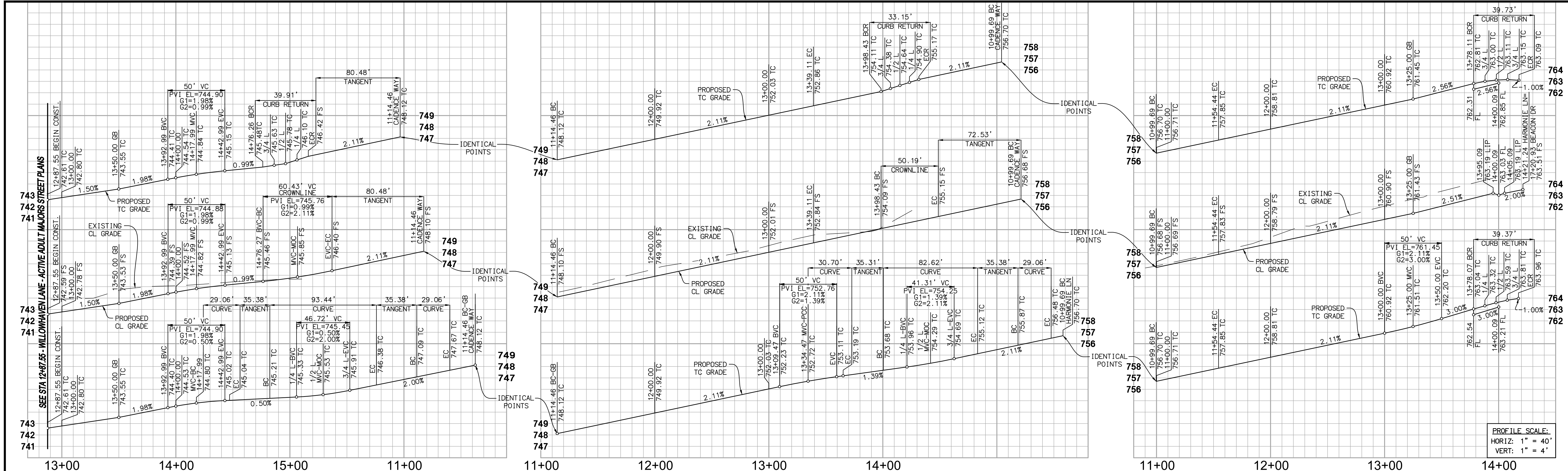

NOTE:
ALL ELEVATIONS ARE ABBREVIATED AND DO NOT REPRESENT ACTUAL ELEVATIONS. ADD 2000 FEET TO OBTAIN ACTUAL ELEVATION.

NOTE:
WORK CONTAINED WITHIN THESE PLANS SHALL NOT COMMENCE UNTIL AN ENCROACHMENT PERMIT AND/OR A GRADING PERMIT HAS BEEN ISSUED.

THE PRIVATE ENGINEER SIGNING THESE PLANS IS RESPONSIBLE FOR ASSURING THE ACCURACY AND ACCEPTABILITY OF THE DESIGN HEREON, IN THE EVENT OF DISCREPANCIES ARISING AFTER CITY APPROVAL OR DURING CONSTRUCTION, THE PRIVATE ENGINEER SHALL BE RESPONSIBLE FOR DETERMINING AN ACCEPTABLE SOLUTION AND REVISING THE PLANS FOR APPROVED BY THE CITY.

BENCHMARK: CITY OF BEAUMONT NO. 07.A.82
DESCRIPTION:
1-3/8" BRASS CAP MONUMENT MARKED "CITY B.M. 7", LOCATED AT THE S.E. CORNER 14TH AND PENNSYLVANIA AVE., 59 FT. S'LY AND 22 FT. E'LY OF CENTERLINE INTERSECTION, 2 FT. S'LY OF B.C.R.

THIS SHEET SUPERSEDES THE PREVIOUSLY APPROVED SHEET 4 APPROVED ON 4/9/2019 INCLUDING THOSE REVISIONS "CLOUDED" AND LABELED WITH REVISION TRIANGLES.

Michael Baker INTERNATIONAL
75410 Gerald Ford Dr. Ste. 100
Palm Desert, CA 92211
Phone: (760) 346-7481
MBAKERINTL.COM

LINE/CURVE DATA TABLE

NO	BEARING/DELTA	RADIUS	LENGTH	TANGENT
1	N88°50'50"W	---	188.71'	---
2	S65°19'50"E	35.00'	39.91'	22.44'
3	N25°49'20"E	---	80.48'	---
4	S15°08'16"W	110.00'	29.06'	14.62'
5	N10°41'04"E	---	35.38'	---
6	S9°36'21"W	56.00'	93.44'	61.77'
7	N73°42'35"W	---	35.38'	---
8	S15°08'15"W	110.00'	29.06'	14.62'
9	N88°50'50"W	---	130.44'	---
10	N88°50'50"W	---	188.67'	---
11	S65°19'50"E	35.00'	60.43'	33.98'
12	N25°49'20"E	---	58.27'	---
13	S15°08'15"W	110.00'	237.61'	124.22'
14	N67°04'39"E	---	59.32'	---
15	S4°15'42"W	35.00'	33.15'	17.93'
16	N12°48'57"E	---	72.53'	---
17	S15°08'15"W	110.00'	29.06'	14.62'
18	N02°19'18"W	---	35.38'	---
19	S84°13'36"W	56.00'	82.62'	50.62'
20	N82°12'54"E	---	35.31'	---
21	S15°08'15"W	110.00'	30.70'	15.45'
22	S40°24'11"W	294.00'	207.32'	108.18'
23	N25°49'20"E	---	22.21'	---
24	S41°15'19"W	312.00'	224.65'	117.44'
25	N67°04'39"E	---	59.32'	---
26	S4°15'42"W	53.00'	50.19'	27.16'
27	N12°48'57"E	---	62.13'	---
28	S12°32'49"W	232.00'	50.80'	25.50'
29	N00°16'08"E	---	223.67'	---
30	S91°03'44"W	25.00'	39.73'	25.47'
31	S90°08'27"W	25.00'	39.37'	25.06'
32	N00°16'08"E	---	223.63'	---
33	S12°32'49"W	268.00'	58.69'	29.46'
34	N12°48'57"E	---	10.40'	---
35	N12°48'57"E	250.00'	54.75'	27.48'
36	N00°16'08"E	---	266.80'	---
37	N25°49'20"E	---	22.21'	---
38	N88°50'50"W	---	33.98'	---
39	N88°50'50"W	---	33.98'	---
40	N25°49'20"E	---	33.98'	---
41	N67°04'39"E	---	27.16'	---
42	N12°48'57"E	---	27.16'	---

LINE/CURVE DATA TABLE

NO	BEARING/DELTA	RADIUS	LENGTH	TANGENT
15	S4°15'42"W	35.00'	33.15'	17.93'
16	N12°48'57"E	---	72.53'	---
17	S15°08'15"W	110.00'	29.06'	14.62'
18	N02°19'18"W	---	35.38'	---
19	S84°13'36"W	56.00'	82.62'	50.62'
20	N82°12'54"E	---	35.31'	---
21	S15°08'15"W	110.00'	30.70'	15.45'
22	S40°24'11"W	294.00'	207.32'	108.18'
23	N25°49'20"E	---	22.21'	---
24	S41°15'19"W	312.00'	224.65'	117.44'
25	N67°04'39"E	---	59.32'	---
26	S4°15'42"W	53.00'	50.19'	27.16'
27	N12°48'57"E	---	62.13'	---
28	S12°32'49"W	232.00'	50.80'	25.50'
29	N00°16'08"E	---	223.67'	---
30	S91°03'44"W	25.00'	39.73'	25.47'
31	S90°08'27"W	25.00'	39.37'	25.06'
32	N00°16'08"E	---	223.63'	---
33	S12°32'49"W	268.00'	58.69'	29.46'
34	N12°48'57"E	---	10.40'	---
35	N12°48'57"E	250.00'	54.75'	27.48'
36	N00°16'08"E	---	266.80'	---
37	N25°49'20"E	---	22.21'	---
38	N88°50'50"W	---	33.98'	---
39	N88°50'50"W	---	33.98'	---
40	N25°49'20"E	---	33.98'	---
41	N67°04'39"E	---	27.16'	---
42	N12°48'57"E	---	27.16'	---

LINE/CURVE DATA TABLE

NO	BEARING/DELTA	RADIUS	LENGTH	TANGENT
15	S4°15'42"W	35.00'	33.15'	17.93'
16	N12°48'57"E	---	72.53'	---
17	S15°08'15"W	110.00'	29.06'	14.62'
18	N02°19'18"W	---	35.38'	---
19	S84°13'36"W	56.00'	82.62'	50.62'
20	N82°12'54"E	---	35.31'	---
21	S15°08'15"W	110.00'	30.70'	15.45'
22	S40°24'11"W	294.00'	207.32'	108.18'
23	N25°49'20"E	---	22.21'	---
24	S41°15'19"W	312.00'	224.65'	117.44'
25	N67°04'39"E	---	59.32'	---
26	S4°15'42"W	53.00'	50.19'	27.16'
27	N12°48'57"E	---	62.13'	---
28	S12°32'49"W	232.00'	50.80'	25.50'
29	N00°16'08"E	---	223.67'	---
30	S91°03'44"W	25.00'	39.73'	25.47'
31	S90°08'27"W	25.00'	39.37'	25.06'
32	N00°16'08"E	---	223.63'	---
33	S12°32'49"W	268.00'	58.69'	29.46'
34	N12°48'57"E	---	10.40'	---
35	N12°48'57"E	250.00'	54.75'	27.48'
36	N00°16'08"E	---	266.80'	---
37	N25°49'20"E	---	22.21'	---
38	N88°50'50"W	---	33.98'	---
39	N88°50'50"W	---	33.98'	---
40	N25°49'20"E	---	33.98'	---
41	N67°04'39"E	---	27.16'	---
42	N12°48'57"E	---	27.16'	---

- CONSTRUCTION NOTES
- 1) CONSTRUCT 4" AC PAVING OVER 6" CLASS II AGGREGATE BASE
 - 2) CONSTRUCT TYPE A CURB AND GUTTER PER RCTD STD. NO. 200
 - 3) CONSTRUCT 10' CROSS GUTTER AND SPANDREL PER RCTD STD. NO. 209
 - 4) CONSTRUCT SIDEWALK PER RCTD STD. NO. 41 (MODIFIED, WIDTH=5')
 - 5) CONSTRUCT CURB RAMP, CASE B (WITH TRUNCATED DOMES) PER RCTD STD. NO. 403
 - 6) CONSTRUCT 18" WIDE DRIVEWAY APPROACH PER DETAIL ON SHEET NO. 1
 - 7) INSTALL STREET NAME SIGN PER RCTD STD. NO. 816
 - 8) INSTALL STREET LIGHT PER SEPARATE STREET LIGHT PLAN
 - 9) INSTALL STOP BAR AND LEGEND PER CALTRANS STD. A24D AND A24E
 - 10) INSTALL R-1 STOP SIGN



BENCHMARK: CITY OF BEAUMONT NO. 07.A.82
DESCRIPTION:
1-3/8" BRASS CAP MONUMENT MARKED "CITY B.M. 7", LOCATED AT THE S.E. CORNER 14TH AND PENNSYLVANIA AVE., 59 FT. S'LY AND 22 FT. E'LY OF CENTERLINE INTERSECTION, 2 FT. S'LY OF B.C.R.

Michael Baker INTERNATIONAL
75410 Gerald Ford Dr. Ste. 100
Palm Desert, CA 92211
Phone: (760) 346-7481
MBAKERINTL.COM

John D. Tanner III, P.E.
R.C.E. 60132 EXP. 06-30-2022

City of Beaumont logo with text 'CITY OF BEAUMONT CALIFORNIA INC. NOV. 19, 1972' and 'DESIGN BY: LS', 'DRAWN BY: LS', 'CHECKED BY: SM', 'SCALE: AS NOTED', 'DATE: MAY 2021', 'JOB NUMBER: 149255'

Reviewed By: _____ Date: _____
Recommended for Approval By: _____ Date: 07/14/2021
Approved By: _____ Date: 07/20/2021

CITY OF BEAUMONT, CALIFORNIA
STREET IMPROVEMENT PLANS
TRACT 31470-6
WILLOWHAVEN LANE STA. 12+87.55 TO STA. 15+10.25
CADENCE WAY STA. 10+00.00 TO STA. 14+25.59
HARMONIE LANE STA. 10+00.00 TO STA. 14+21.24
A PORTION OF SEC. 35, T 2 S, R 1 W, S8M
TRI POINTE HOMES
NPDES PERMIT#: W01D 833C365311
SF17-4086
SHEET 4
OF 8 SHEETS
FILE NO: 3247A

PROFILE SCALE:
HORIZ: 1" = 40'
VERT: 1" = 4'

REVISED: 06/24/2021

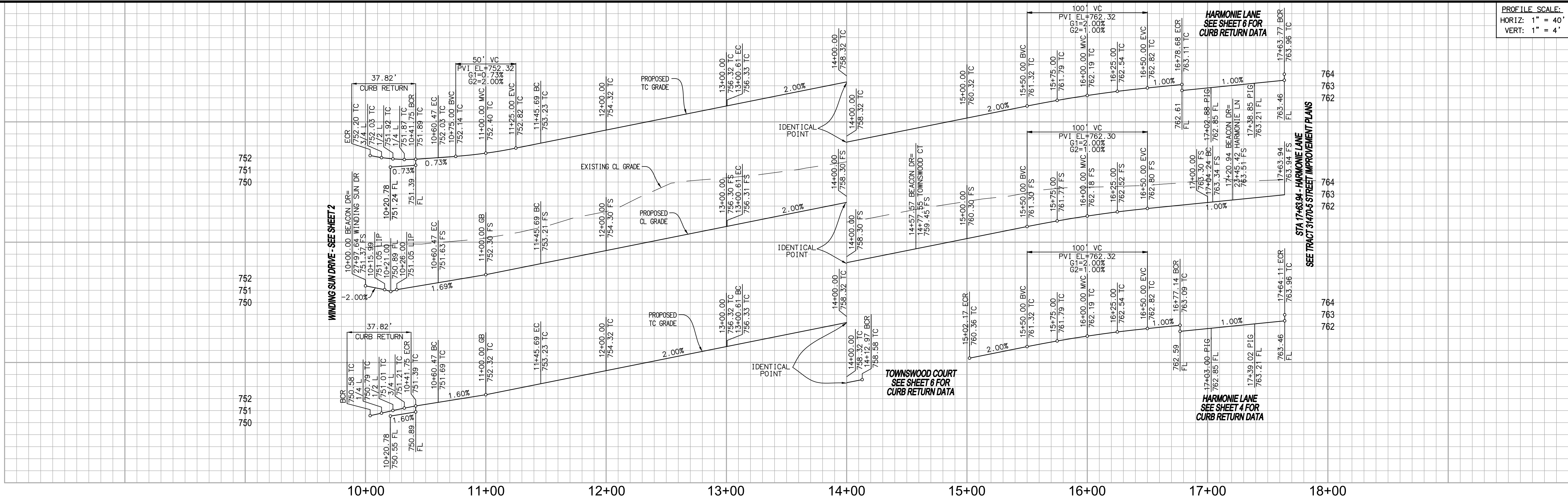

NO	BEARING/Delta	RADIUS	LENGTH	TANGENT
1	86°40'56"	25.00'	37.82'	23.59'
2	N 89°09'01" W	---	18.72'	---
3	19°31'54"	232.00'	79.09'	39.93'
4	N 71°19'05" E	---	154.92'	---
5	17°57'42"	1224.00'	383.71'	193.44'
6	N 89°09'01" W	---	60.47'	---
7	19°31'54"	250.00'	85.22'	43.03'
8	N 71°19'05" E	---	154.92'	---
9	19°10'35"	1206.00'	403.63'	203.72'
10	N 89°30'21" W	---	59.70'	---
11	86°40'56"	25.00'	37.82'	23.59'
12	N 89°09'01" W	---	18.72'	---
13	19°31'54"	268.00'	91.36'	46.13'
14	N 71°19'05" E	---	154.92'	---
15	05°20'17"	1188.00'	110.68'	55.38'
16	08°18'46"	1188.00'	172.36'	86.33'

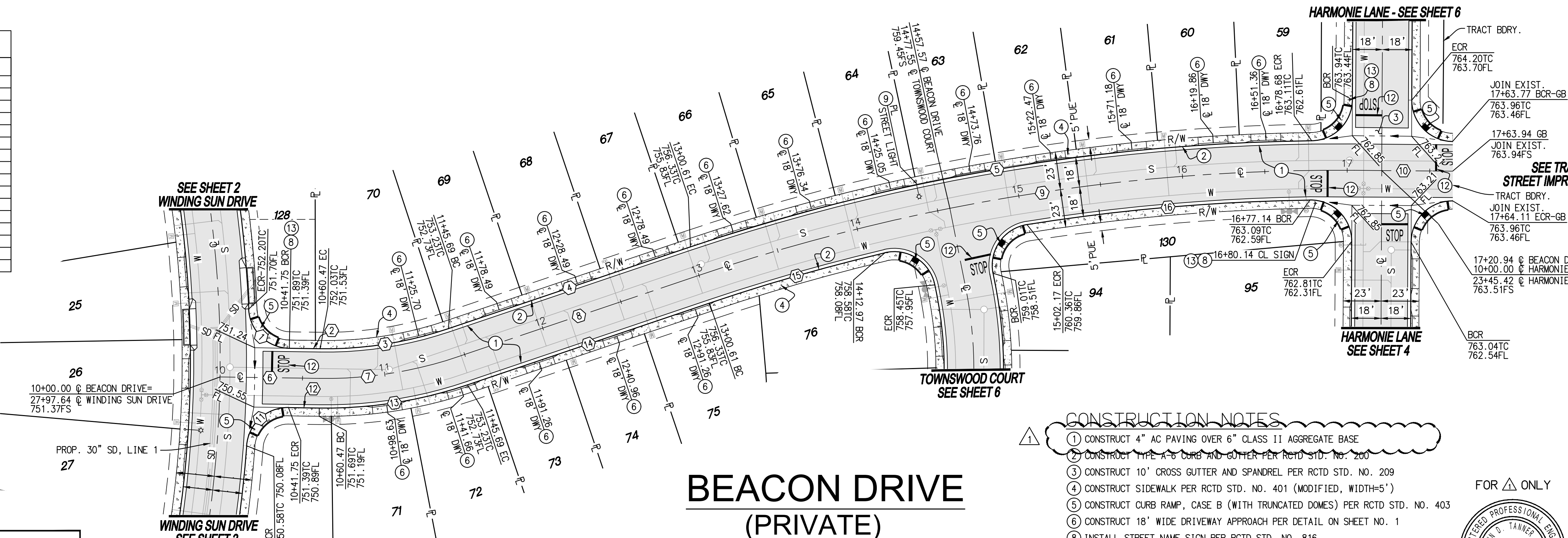
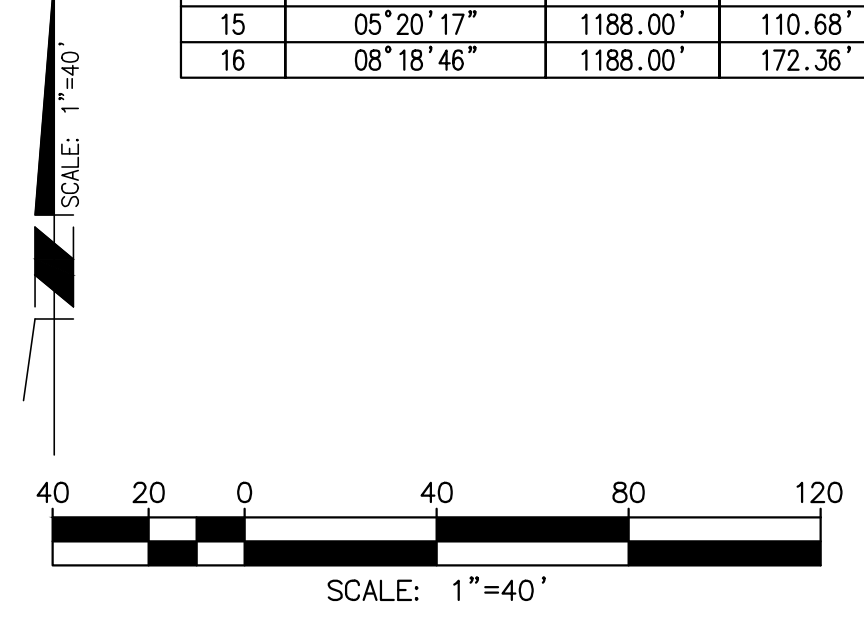

- CONSTRUCTION NOTES**
- CONSTRUCT 4" AC PAVING OVER 6" CLASS II AGGREGATE BASE
 - CONSTRUCT TYPE A CURB AND GUTTER PER RCTD STD. NO. 200
 - CONSTRUCT 10" CROSS GUTTER AND SPANDREL PER RCTD STD. NO. 209
 - CONSTRUCT SIDEWALK PER RCTD STD. NO. 401 (MODIFIED, WIDTH=5')
 - CONSTRUCT CURB RAMP, CASE B (WITH TRUNCATED DOMES) PER RCTD STD. NO. 403
 - CONSTRUCT 18" WIDE DRIVEWAY APPROACH PER DETAIL ON SHEET NO. 1
 - INSTALL STREET NAME SIGN PER RCTD STD. NO. 816
 - INSTALL STREET LIGHT PER SEPARATE STREET LIGHT PLAN
 - INSTALL STOP BAR AND LEGEND PER CALTRANS STD. A24D AND A24E
 - INSTALL R-1 STOP SIGN

THIS SHEET SUPERSEDES THE PREVIOUSLY APPROVED SHEET 5 APPROVED ON 4/9/2019 INCLUDING THOSE REVISIONS "CLOUDED" AND LABELED WITH Δ REVISION TRIANGLES.

FOR Δ ONLY

6/24/2021
JOHN D. TANNER III, P.E. DATE
R.C.E. 60132 EXP. 06-30-2022

NOTE:
ALL ELEVATIONS ARE ABBREVIATED AND DO NOT REPRESENT ACTUAL ELEVATIONS. ADD 2000 FEET TO OBTAIN ACTUAL ELEVATION.

NOTE:
WORK CONTAINED WITHIN THESE PLANS SHALL NOT COMMENCE UNTIL AN ENCROACHMENT PERMIT AND/OR A GRADING PERMIT HAS BEEN ISSUED.

THE PRIVATE ENGINEER SIGNING THESE PLANS IS RESPONSIBLE FOR ASSURING THE ACCURACY AND ACCEPTABILITY OF THE DESIGN HEREON. IN THE EVENT OF DISCREPANCIES ARISING AFTER CITY APPROVAL OR DURING CONSTRUCTION, THE PRIVATE ENGINEER SHALL BE RESPONSIBLE FOR DETERMINING AN ACCEPTABLE SOLUTION AND REVISING THE PLANS FOR APPROVED BY THE CITY.

BASIS OF BEARINGS:
DESCRIPTION:
BASED ON THE LINE BETWEEN STATIONS "TRAK" AND "MATH" (POSITIONS PER NATIONAL GEODETIC SURVEY, NAD83, EPOCH 1995.5) AS SHOWN ON M.B. 102, PAGES 50 THROUGH 65 OF RECORDS IN COUNTY RECORDER'S OFFICE OF RIVERSIDE COUNTY, CALIFORNIA

BEARING: N 52°49'02.84" E

BENCHMARK: CITY OF BEAUMONT NO. 07.A.82
DESCRIPTION:
1-3/8" BRASS CAP MONUMENT MARKED "CITY B.M. 7", LOCATED AT THE S.E. CORNER 14TH AND PENNSYLVANIA AVE., 59 FT. S'LY AND 22 FT. E'LY OF CENTERLINE INTERSECTION, 2 FT. S'LY OF B.C.R.

ELEV. = 2678.277 (1982), NGVD 29

BY	MARK	DESCRIPTION	APPR.	DATE
JZ	Δ	REVISED CONST. NOTE 1.		6/24/21
BY	MARK	DESCRIPTION	APPR.	DATE
ENGINEER		REVISIONS	CITY	

Michael Baker INTERNATIONAL
75410 Gerald Ford Dr. Ste.100
Palm Desert, CA 92211
Phone: (760) 346-7481
MBAKERINTL.COM

SEAL
REGISTERED PROFESSIONAL ENGINEER
JOHN D. TANNER III
No. 60132
CIVIL
STATE OF CALIFORNIA

DESIGN BY: LS
DRAWN BY: LS
CHECKED BY: SM
SCALE: AS NOTED
DATE: MAY 2021
JOB NUMBER: 149255

6/24/2021
JOHN D. TANNER III
R.C.E. 60132 * EXP. 06/30/22

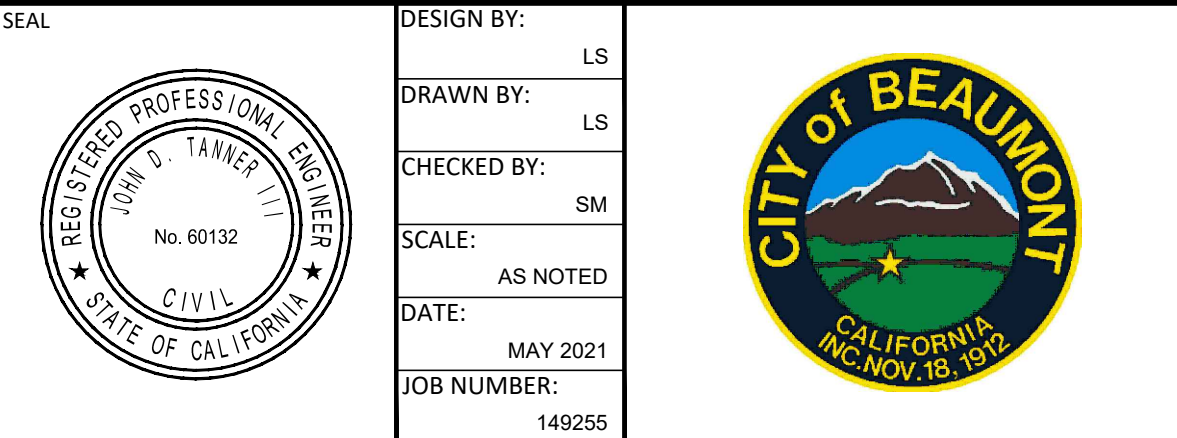

Reviewed By: _____ Date: _____
Recommended for Approval By: _____ Date: 07/14/2021
Approved By: _____ Date: 07/20/2021

CITY OF BEAUMONT, PUBLIC WORKS DEPARTMENT
ENGINEERING DIVISION

NPDES PERMIT#: W01D 833C365311

CITY OF BEAUMONT, CALIFORNIA
STREET IMPROVEMENT PLANS
TRACT 31470-6

BEACON DRIVE
STA. 10+00.00 TO STA. 17+63.94

A PORTION OF SEC. 35, T 2 S, R 1 W, SBM

FOR: TRI POINTE HOMES

SHEET
5
OF 8 SHEETS
FILE NO.: 3247A

H:\PDATA\146481\CADD\LAND\DM\IMPROVE\STREET\31470-6\149255-ST-005.DWG JACOB.ZEPEDA 3/30/21 1:59 PM

PROFILE SCALE:
HORIZ: 1" = 40'
VERT: 1" = 4'

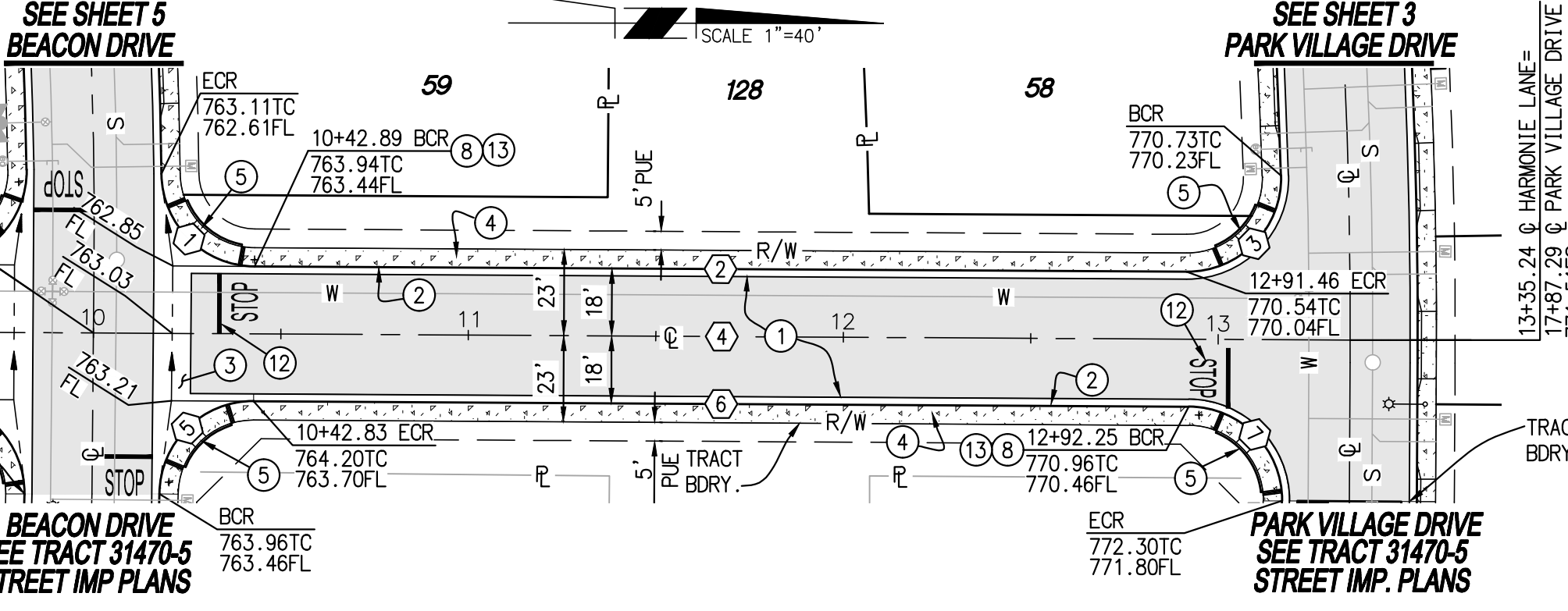
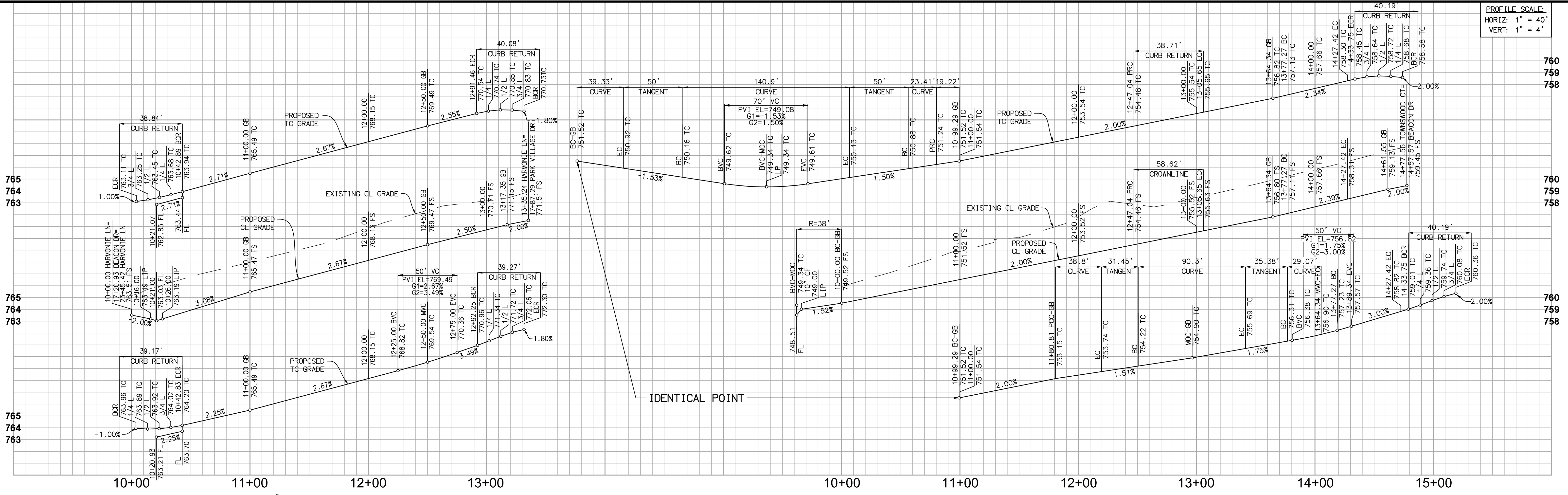

- CONSTRUCTION NOTES**
- CONSTRUCT 4" AC PAVING OVER 6" CLASS 11 AGGREGATE BASE
 - CONSTRUCT 18" A.C. CURB AND GUTTER PER RCTD STD. NO. 260
 - CONSTRUCT 10" CROSS GUTTER AND SPANDREL PER RCTD STD. NO. 209
 - CONSTRUCT SIDEWALK PER RCTD STD. NO. 401 (MODIFIED, WIDTH=5')
 - CONSTRUCT CURB RAMP, CASE B (WITH TRUNCATED DOMES) PER RCTD STD. NO. 403
 - CONSTRUCT 18" WIDE DRIVEWAY APPROACH PER DETAIL ON SHEET NO. 1
 - CONSTRUCT GUTTER DEPRESSION FOR CURB OPENING CATCH BASIN PER COUNTY OF RIVERSIDE STD. NO. 311, CASE C
 - INSTALL STREET NAME SIGN PER RCTD STD. NO. 816
 - INSTALL STREET LIGHT PER SEPARATE STREET LIGHT PLAN
 - INSTALL STOP BAR AND LEGEND PER CALTRANS STD. A24D AND A24E
 - INSTALL R-1 STOP SIGN
 - CONSTRUCT CATCH BASIN PER RCTD & WCD STD. NO. CB100 (W & V PER PLAN)
 - CONSTRUCT 12.5' WIDE DRIVEWAY APPROACH PER DETAIL ON SHEET NO. 1

THIS SHEET SUPERSEDES THE PREVIOUSLY APPROVED SHEET 6 APPROVED ON 4/9/2019 INCLUDING THOSE REVISIONS "CLOUDED" AND LABELED WITH Δ REVISION TRIANGLES.

FOR Δ ONLY

REGISTERED PROFESSIONAL ENGINEER
No. 60132
CIVIL
STATE OF CALIFORNIA

JOHN D. TANNER III, P.E. DATE 6/24/2021
R.C.E. 60132 EXP. 06-30-2022

TOWNSWOOD COURT (PRIVATE)

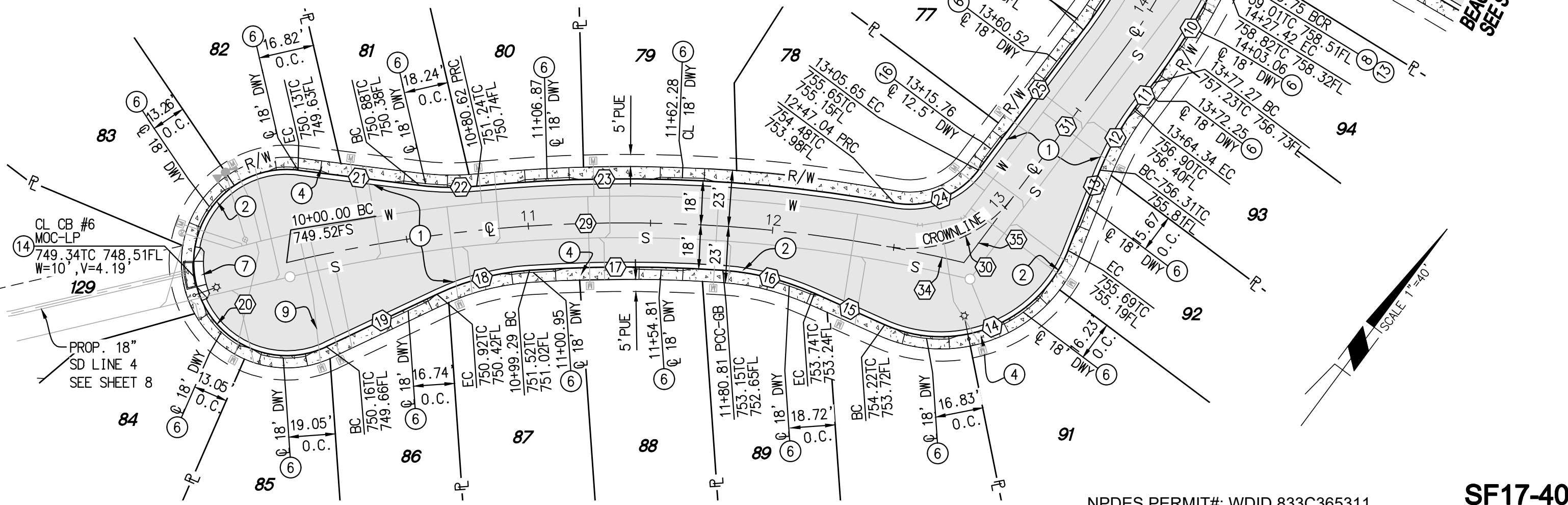

LINE/CURVE DATA TABLE					LINE/CURVE DATA TABLE				
NO	BEARING/DELTA	RADIUS	LENGTH	TANGENT	NO	BEARING/DELTA	RADIUS	LENGTH	TANGENT
1	89°00'39"	25.00'	38.84'	24.57'	19	N 28°04'20" E	---	50.00'	---
2	N 00°16'08" E	---	248.57'	---	20	212°26'37"	38.00'	140.90'	---
3	91°51'18"	25.00'	40.08'	25.82'	21	N 60°30'57" E	---	50.00'	---
4	N 00°16'08" E	---	335.24'	---	22	12°46'20"	105.00'	23.41'	11.75'
5	89°46'29"	25.00'	39.17'	24.90'	23	15°53'31"	618.00'	171.41'	86.26'
6	N 00°16'08" E	---	249.42'	---	24	63°22'00"	35.00'	38.71'	21.60'
7	90°00'00"	25.00'	39.27'	25.00'	25	N 00°16'08" E	---	71.61'	---
8	92°07'08"	25.00'	40.19'	25.94'	26	11°29'38"	232.00'	46.54'	23.35'
9	N 11°13'30" W	---	6.34'	---	27	N 11°13'30" W	---	6.34'	---
10	11°29'38"	268.00'	53.76'	26.97'	28	92°07'08"	25.00'	40.19'	25.94'
11	N 00°16'08" E	---	12.93'	---	29	23°35'26"	600.00'	247.04'	125.29'
12	15°08'15"	110.00'	29.07'	14.62'	30	63°22'00"	53.00'	58.62'	32.71'
13	N 14°52'07" W	---	35.38'	---	31	N 00°16'08" E	---	71.61'	---
14	92°23'23"	56.00'	90.30'	58.39'	32	11°29'38"	250.00'	50.15'	25.16'
15	N 77°31'16" E	---	31.45'	---	33	N 11°13'30" W	---	50.13'	---
16	20°12'34"	110.00'	38.80'	19.60'	34	03°05'01"	600.00'	32.29'	16.15'
17	07°47'06"	582.00'	79.08'	39.60'	35	N 00°16'08" E	---	33.68'	---
18	21°27'16"	105.00'	39.33'	19.89'					

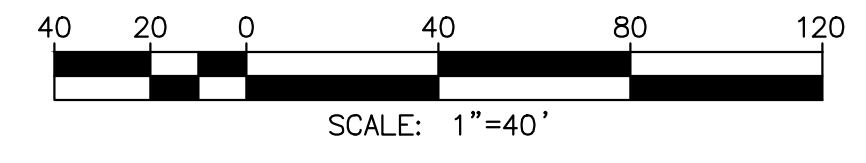

NOTE:
ALL ELEVATIONS ARE ABBREVIATED AND DO NOT REPRESENT ACTUAL ELEVATIONS. ADD 2000 FEET TO OBTAIN ACTUAL ELEVATION.

NOTE:
WORK CONTAINED WITHIN THESE PLANS SHALL NOT COMMENCE UNTIL AN ENCROACHMENT PERMIT AND/OR A GRADING PERMIT HAS BEEN ISSUED.

THE PRIVATE ENGINEER SIGNING THESE PLANS IS RESPONSIBLE FOR ASSURING THE ACCURACY AND ACCEPTABILITY OF THE DESIGN HEREON, IN THE EVENT OF DISCREPANCIES ARISING AFTER CITY APPROVAL OR DURING CONSTRUCTION, THE PRIVATE ENGINEER SHALL BE RESPONSIBLE FOR DETERMINING AN ACCEPTABLE SOLUTION AND REVISING THE PLANS FOR APPROVED BY THE CITY.

BASIS OF BEARINGS:
DESCRIPTION:
BASED ON THE LINE BETWEEN STATIONS "TRAK" AND "MATH" (POSITIONS PER NATIONAL GEODETIC SURVEY, NAD83, EPOCH 1995.5) AS SHOWN ON M.B. 102, PAGES 50 THROUGH 65 OF RECORDS IN COUNTY RECORDER'S OFFICE OF RIVERSIDE COUNTY, CALIFORNIA
BEARING: N 52°49'02.84" E

BENCHMARK: CITY OF BEAUMONT NO. 07.A.82
DESCRIPTION:
1-3/8" BRASS CAP MONUMENT MARKED "CITY B.M. 7", LOCATED AT THE S.E. CORNER 14TH AND PENNSYLVANIA AVE., 59 FT. S'LY AND 22 FT. E'LY OF CENTERLINE INTERSECTION, 2 FT. S'LY OF B.C.R.
ELEV. = 2678.277 (1982), NGVD 29

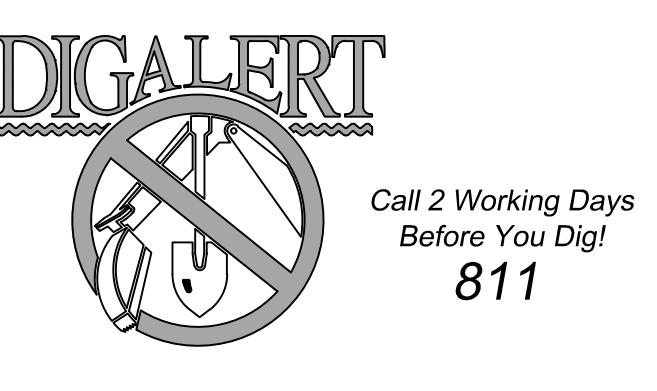

BY	MARK	DESCRIPTION	APPR.	DATE
JZ	Δ	REVISED CONST. NOTE 1.		6/24/21
		REVISIONS		CITY

Michael Baker INTERNATIONAL
75410 Gerald Ford Dr. Ste. 100
Palm Desert, CA 92211
Phone: (760) 346-7481
MBAKERINTL.COM

SEAL
REGISTERED PROFESSIONAL ENGINEER
No. 60132
CIVIL
STATE OF CALIFORNIA

DESIGN BY: LS
DRAWN BY: LS
CHECKED BY: SM
SCALE: AS NOTED
DATE: MAY 2021
JOB NUMBER: 149255

JOHN D. TANNER III
R.C.E. 60132 * EXP. 06/30/22



Reviewed By: _____ Date: _____
Recommended for Approval By: _____ Date: 07/14/2021
Approved By: *John D. Tanner III* Date: 07/20/2021

CITY OF BEAUMONT, PUBLIC WORKS DEPARTMENT
ENGINEERING DIVISION

NPDES PERMIT#: WDD1 833C365311

CITY OF BEAUMONT, CALIFORNIA
STREET IMPROVEMENT PLANS
TRACT 31470-6
HARMONIE LANE
STA. 10+00.00 TO STA. 13+35.24
TOWNSWOOD COURT
STA. 10+00.00 TO STA. 14+77.55
A PORTION OF SEC. 35, T 2 S, R 1 W, SBM

FOR:
TRI POINTE HOMES

SHEET
6
OF 8 SHEETS
FILE NO.:
3247A

REVISED: 06/24/2021
H:\PDATA\146481\CADD\LAND\IMPROVE\STREE\31470-6\149255-ST-006.DWG JACOB.ZEPEDA 3/30/21 2:29 PM

PROFILE SCALE:
HORIZ: 1" = 40'
VERT: 1" = 4'

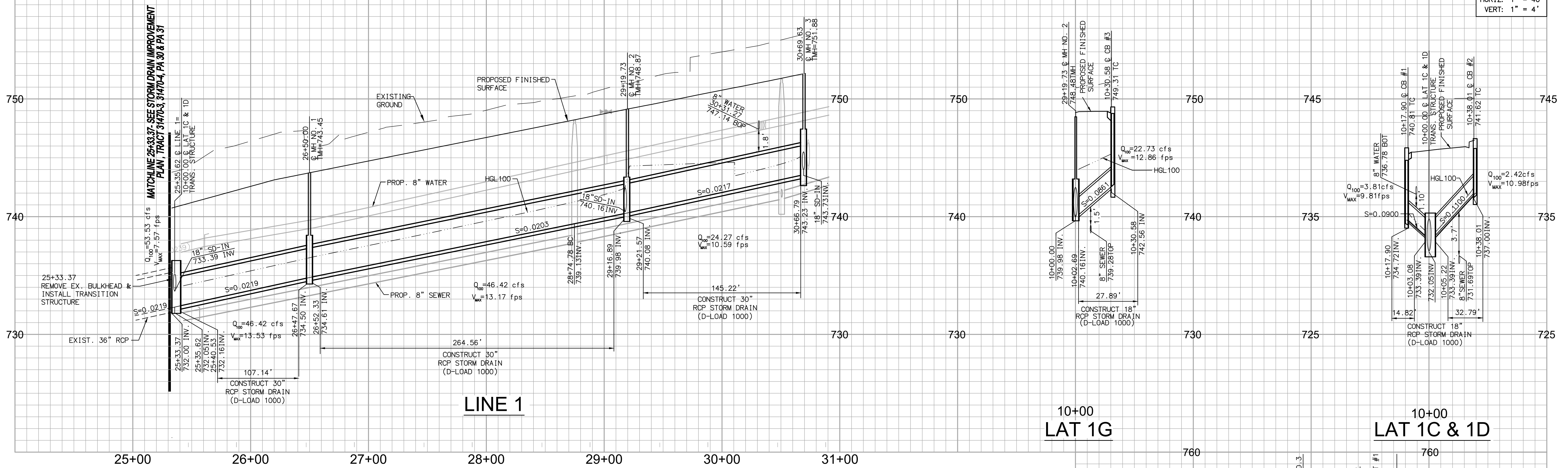

10+00
LAT 1G

10+00
LAT 1C & 1D

MATCHLINE 25+33.37- SEE STORM DRAIN IMPROVEMENT PLAN, TRACT 31470-3, 31470-4, PA 30 & PA 31

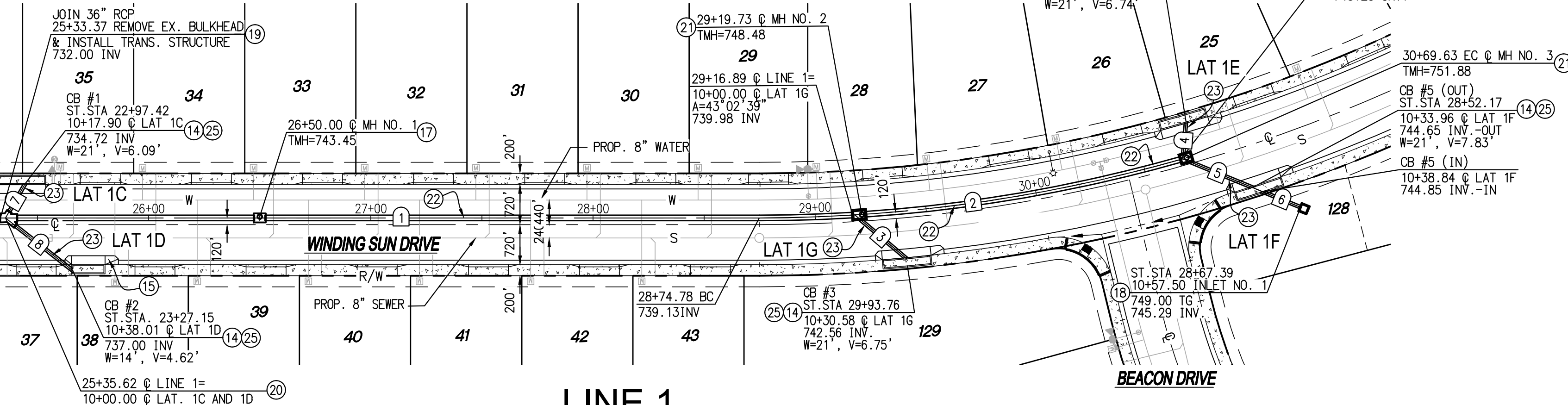

LINE 1

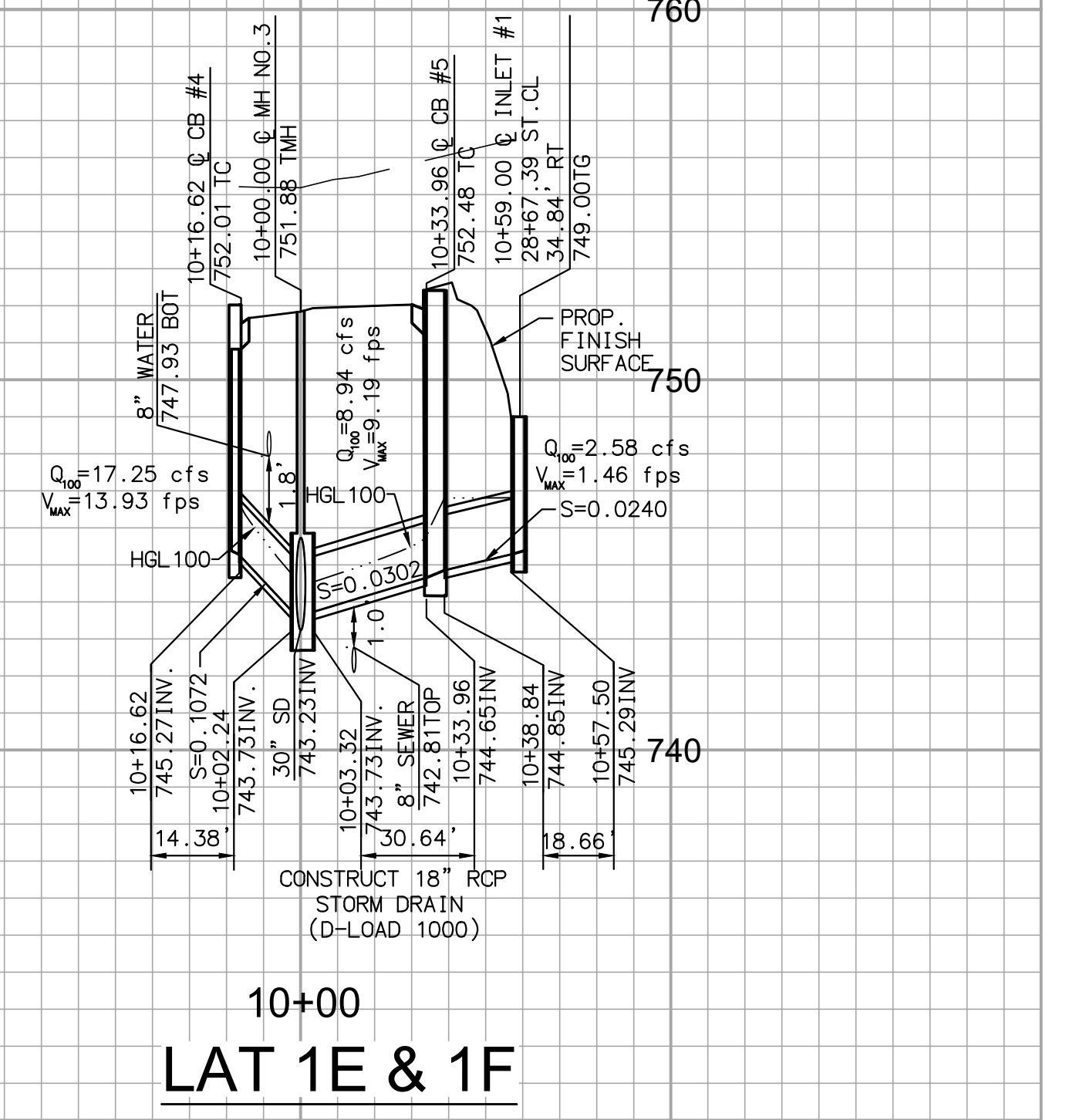

10+00
LAT 1E & 1F

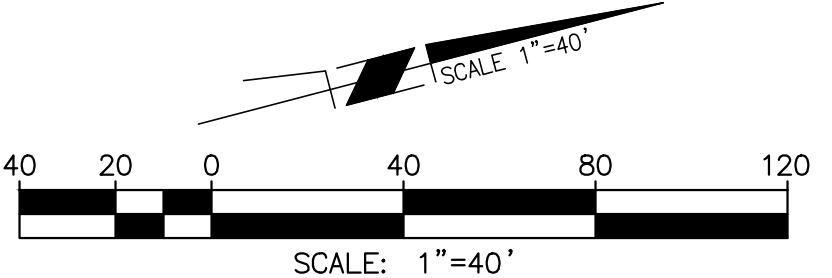

CONSTRUCTION NOTES

- (14) CONSTRUCT CATCH BASIN PER RCFCD & WCD STD. NO. CB100 (W & V PER PLAN)
- (15) CONSTRUCT GUTTER DEPRESSION FOR CURB OPENING CATCH BASIN PER COUNTY OF RIVERSIDE STD. NO. 311, CASE B
- (17) CONSTRUCT MANHOLE NO. 1 PER RCFCD & WCD STD. NO. MH251
- (18) INSTALL 36" SQUARE DRAIN INLET PER JENSEN PRECAST DI3636 OR APPROVED EQUAL
- (19) REMOVE EXISTING CONCRETE BULKHEAD PER RCFCD & WCD STD. NO. M816
- (21) CONSTRUCT MANHOLE NO. 4 PER RCFCD & WCD STD. NO. MH254
- (22) INSTALL 30" RCP OR CIPP STORM DRAIN (D-LOAD PER PLAN)
- (23) INSTALL 18" RCP OR CIPP STORM DRAIN (D-LOAD PER PLAN)
- (25) INSTALL CONNECTOR PIPE SCREEN PER UNITED STORM WATER, INC OR APPROVED EQUAL

LINE/CURVE DATA TABLE			
NO	BEARING/DELTA	RADIUS	LENGTH
1	N14°37'03"E	---	341.41'
2	15°52'17"	697.00'	194.85'
3	N54°51'12"E	---	30.58'
4	N70°23'07"W	---	16.62'
5	N36°57'17"E	---	33.96'
6	N36°57'17"E	---	18.66'
7	N45°22'57"W	---	17.90'
8	N52°41'08"E	---	38.01'

NOTE:
ALL ELEVATIONS ARE ABBREVIATED AND DO NOT REPRESENT ACTUAL ELEVATIONS. ADD 2000 FEET TO OBTAIN ACTUAL ELEVATION.

NOTE:
WORK CONTAINED WITHIN THESE PLANS SHALL NOT COMMENCE UNTIL AN ENCROACHMENT PERMIT AND/OR A GRADING PERMIT HAS BEEN ISSUED.

THE PRIVATE ENGINEER SIGNING THESE PLANS IS RESPONSIBLE FOR ASSURING THE ACCURACY AND ACCEPTABILITY OF THE DESIGN HEREON, IN THE EVENT OF DISCREPANCIES ARISING AFTER CITY APPROVAL OR DURING CONSTRUCTION, THE PRIVATE ENGINEER SHALL BE RESPONSIBLE FOR DETERMINING AN ACCEPTABLE SOLUTION AND REVISING THE PLANS FOR APPROVED BY THE CITY.

BASIS OF BEARINGS:
DESCRIPTION:
BASED ON THE LINE BETWEEN STATIONS "TRAK" AND "MATH" (POSITIONS PER NATIONAL GEODETIC SURVEY, NAD83, EPOCH 1995.5) AS SHOWN ON M.B. 102, PAGES 50 THROUGH 65 OF RECORDS IN COUNTY RECORDER'S OFFICE OF RIVERSIDE COUNTY, CALIFORNIA
BEARING: N 52°49'02.84" E

BENCHMARK: CITY OF BEAUMONT NO. 07.A.82
DESCRIPTION:
1-3/8" BRASS CAP MONUMENT MARKED "CITY B.M. 7", LOCATED AT THE S.E. CORNER 14TH AND PENNSYLVANIA AVE., 59 FT. S'LY AND 22 FT. E'LY OF CENTERLINE INTERSECTION, 2 FT. S'LY OF B.C.R.
ELEV. = 2678.277 (1982), NGVD 29

BY	MARK	DESCRIPTION	APPR.	DATE

Michael Baker INTERNATIONAL
75410 Gerald Ford Dr. Ste.100
Palm Desert, CA 92211
Phone: (760) 346-7481
MBAKERINTL.COM

JOHN D. TANNER III
R.C.E. - 60132 * EXP. 06/30/22



DESIGN BY: LS
DRAWN BY: LS
CHECKED BY: MBS
SCALE: AS NOTED
DATE: MAY 2021
JOB NUMBER: 149255



Reviewed By: _____ Date: _____
Recommended for Approval By: *[Signature]* Date: 07/14/2021
Approved By: *[Signature]* Date: 07/20/2021

CITY OF BEAUMONT, PUBLIC WORKS DEPARTMENT
ENGINEERING DIVISION

NPDES PERMIT#: WDD1 833C365311

CITY OF BEAUMONT, CALIFORNIA
STORM DRAIN IMPROVEMENT PLANS
TRACT 31470-6

LINE 1 - FROM STA. 25+33.37 TO STA. 30+69.63
LINE 11 - FROM STA. 10+00.00 TO STA. 10+47.24
LATERALS 1C, 1D, 1E, 1F, 11A AND 11B

A PORTION OF SEC. 35, T 2 S, R 1 W, SBM

FOR:
TRI POINTE HOMES

SHEET
7
OF 8 SHEETS
FILE NO.: **3247A**

REVISED: 06/24/2021
H:\PDATA\146481\CAD\LAND\IMPROVE\STREET\31470-6\149255-SD-007.DWG JACOB.ZEPEDA 2/8/21 2:05 PM

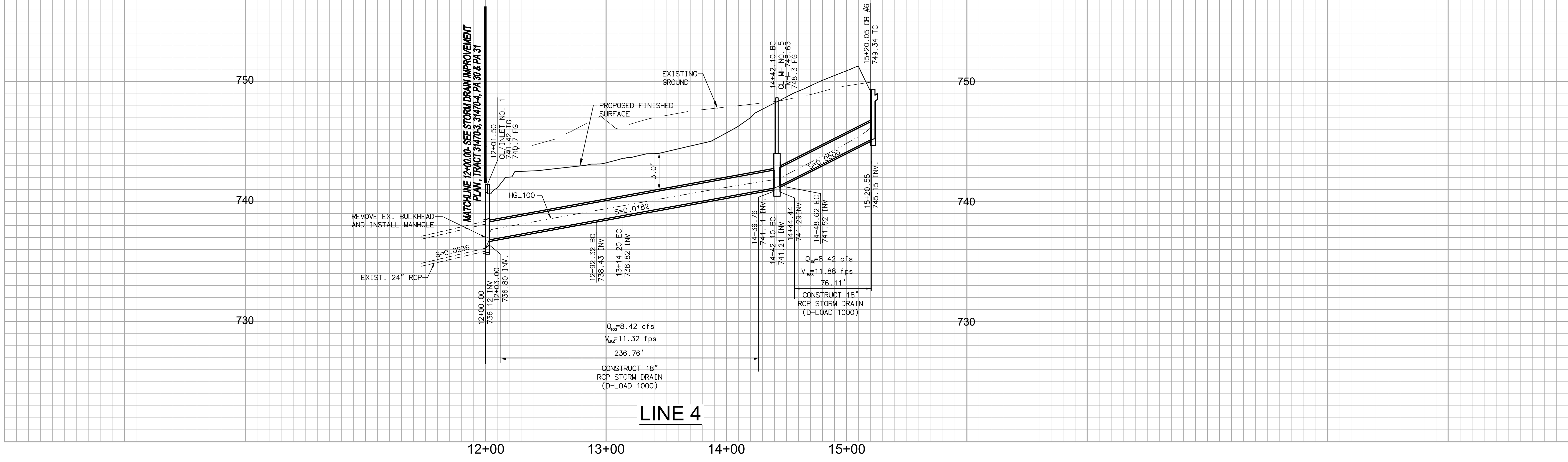

NO	BEARING/Delta	RADIUS	LENGTH	TANGENT
1	N01°09'10"E	--	92.32'	--
2	S5°42'44"E	22.50'	21.88'	11.89'
3	N56°51'54"E	--	35.80'	--
4	N56°51'54"E	--	92.10'	--
5	S16°36'57"E	22.50'	6.52'	3.29'
6	N40°14'57"E	--	71.93'	--

CONSTRUCTION NOTES

- 14 CONSTRUCT CATCH BASIN PER RCFCD & WCD STD. NO. CB100 (W & V PER PLAN)
- 19 REMOVE EXISTING CONCRETE BULKHEAD PER RCFCD & WCD STD. NO. M816
- 21 CONSTRUCT MANHOLE NO. 4 PER RCFCD & WCD STD. NO. M4254
- 23 INSTALL 18" RCP OR CIPP STORM DRAIN (D-LOAD PER PLAN)
- 24 INSTALL INLET TYPE X PER RCFCD & WCD STD. NO. CB108
- 25 INSTALL CONNECTOR PIPE SCREEN PER UNITED STORM WATER, INC OR APPROVED EQUAL

**SEE STORM DRAIN IMPROVEMENT PLAN
TRACT 3140-3, 31470-4, PA 30 & PA31
WILLOWHAVEN LANE**

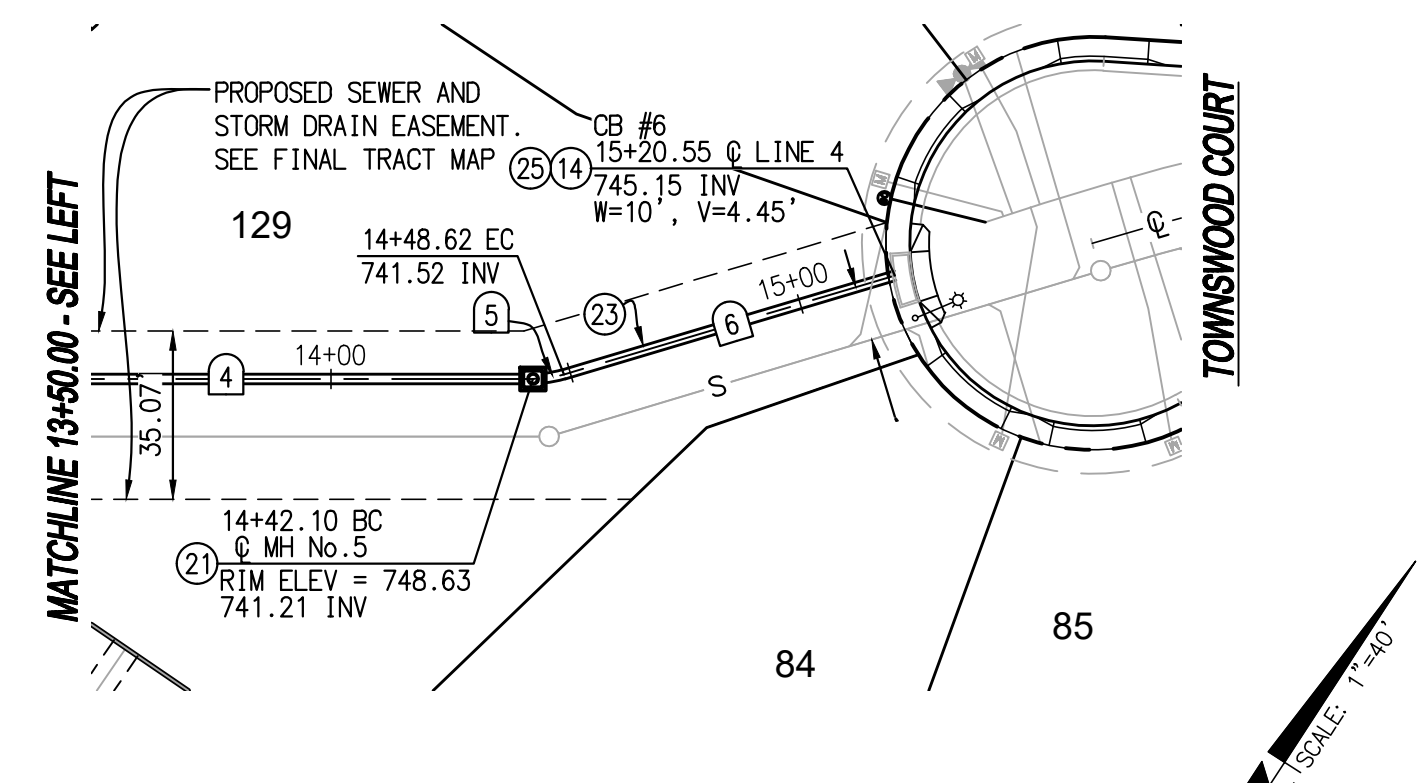
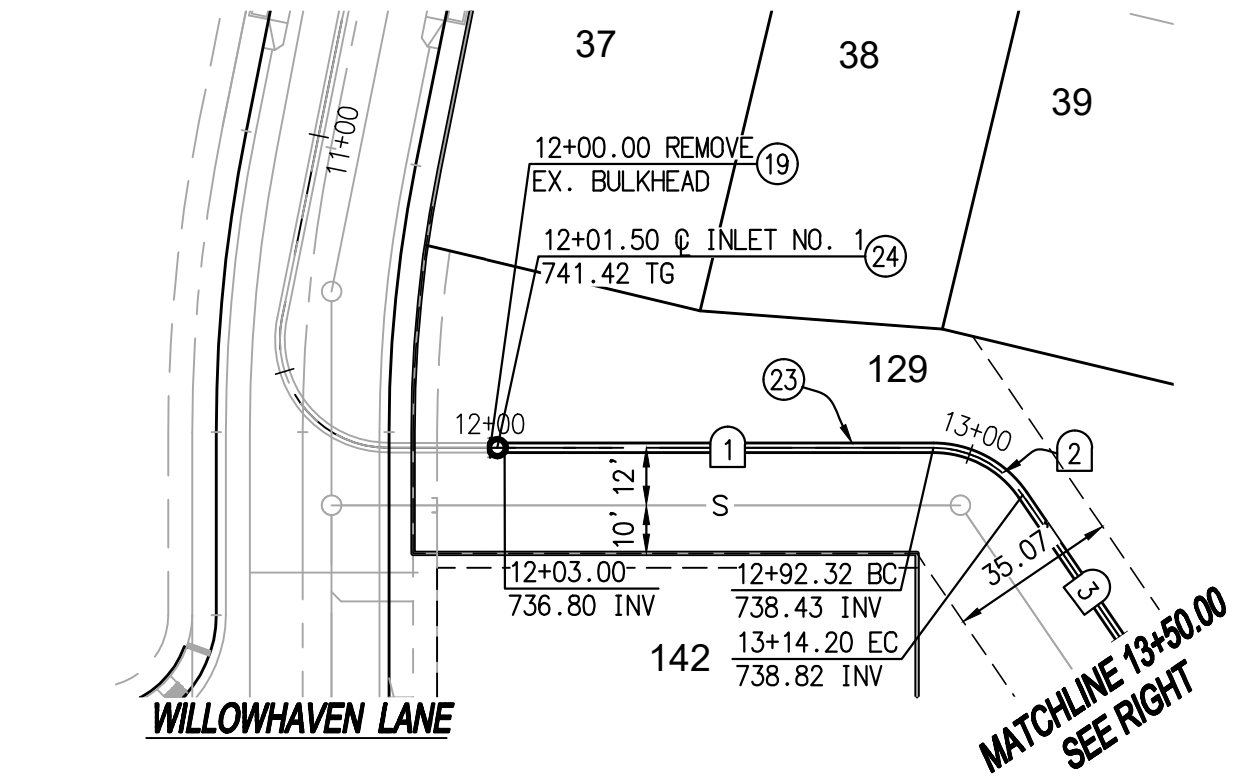

NOTE:
ALL ELEVATIONS ARE ABBREVIATED AND DO NOT REPRESENT ACTUAL ELEVATIONS. ADD 2000 FEET TO OBTAIN ACTUAL ELEVATION.

NOTE:
WORK CONTAINED WITHIN THESE PLANS SHALL NOT COMMENCE UNTIL AN ENCROACHMENT PERMIT AND/OR A GRADING PERMIT HAS BEEN ISSUED.

THE PRIVATE ENGINEER SIGNING THESE PLANS IS RESPONSIBLE FOR ASSURING THE ACCURACY AND ACCEPTABILITY OF THE DESIGN HEREON. IN THE EVENT OF DISCREPANCIES ARISING AFTER CITY APPROVAL OR DURING CONSTRUCTION, THE PRIVATE ENGINEER SHALL BE RESPONSIBLE FOR DETERMINING AN ACCEPTABLE SOLUTION AND REVISING THE PLANS FOR APPROVED BY THE CITY.

BASIS OF BEARINGS:
DESCRIPTION:
BASED ON THE LINE BETWEEN STATIONS "TRAK" AND "MATH" (POSITIONS PER NATIONAL GEODETIC SURVEY, NAD83, EPOCH 1995.5) AS SHOWN ON M.B. 102, PAGES 50 THROUGH 65 OF RECORDS IN COUNTY RECORDER'S OFFICE OF RIVERSIDE COUNTY, CALIFORNIA
BEARING: N 52°49'02.84" E

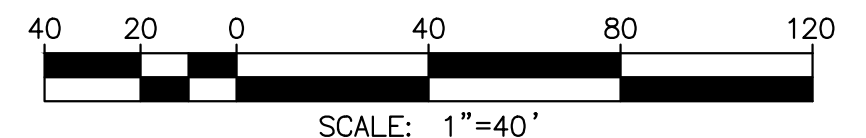

BENCHMARK: CITY OF BEAUMONT NO. 07.A.82
DESCRIPTION:
1-3/8" BRASS CAP MONUMENT MARKED "CITY B.M. 7". LOCATED AT THE S.E. CORNER 14TH AND PENNSYLVANIA AVE., 59 FT. S'LY AND 22 FT. E'LY OF CENTERLINE INTERSECTION, 2 FT. S'LY OF B.C.R.
ELEV. = 2678.277 (1982), NGVD 29

BY	MARK	DESCRIPTION	APPR.	DATE

Michael Baker INTERNATIONAL
75410 Gerald Ford Dr. Ste:100
Palm Desert, CA 92211
Phone: (760) 348-7481
MBAKERINTL.COM

John D. Tanner III
JOHN D. TANNER III
R.L.C.E. 60132 * EXP. 06/30/22
DATE: 6/24/2021

SEAL
REGISTERED PROFESSIONAL ENGINEER
JOHN D. TANNER III
No. 60132
CIVIL
STATE OF CALIFORNIA

DESIGN BY: LS
DRAWN BY: LS
CHECKED BY: MBS
SCALE: AS NOTED
DATE: MAY 2021
JOB NUMBER: 149255

Reviewed By: _____ Date: _____
Recommended for Approval By: *[Signature]* Date: 07/14/2021
Approved By: *[Signature]* Date: 07/20/2021

CITY OF BEAUMONT, PUBLIC WORKS DEPARTMENT
ENGINEERING DIVISION

NPDES PERMIT#: WDDI 833C365311

CITY OF BEAUMONT, CALIFORNIA
STORM DRAIN IMPROVEMENT PLANS
TRACT 31470-6
LINE 4 - FROM STA. 12+00.00 TO STA. 15+20.55

A PORTION OF SEC. 35, T 2 S, R 1 W, SBM

FOR: **TRI POINTE HOMES**

SHEET
8
OF 8 SHEETS
FILE NO: **3247A**